

Алматы (7273)495-231  
Ангарск (3955)60-70-56  
Архангельск (8182)63-90-72  
Астрахань (8512)96-46-04  
Барнаул (3852)73-04-60  
Белгород (4722)40-23-64  
Благовещенск (4162)22-76-07  
Брянск (4832)59-03-52  
Владивосток (423)249-28-31  
Владикавказ (8672)28-90-48  
Владимир (4922)49-43-18  
Волгоград (844)278-03-48  
Вологда (8172)26-41-59  
Воронеж (473)204-51-73  
Екатеринбург (343)384-55-89

Ижевск (3412)26-03-58  
Иваново (4932)77-34-06  
Иркутск (395)279-98-46  
Казань (843)206-01-48  
Калининград (4012)72-03-81  
Калуга (4842)92-23-67  
Кемерово (3842)65-04-62  
Киров (8332)68-02-04  
Коломна (4966)23-41-49  
Кострома (4942)77-07-48  
Краснодар (861)203-40-90  
Красноярск (391)204-63-61  
Курск (4712)77-13-04  
Курган (3522)50-90-47  
Липецк (4742)52-20-81

Магнитогорск (3519)55-03-13  
Москва (495)268-04-70  
Мурманск (8152)59-64-93  
Набережные Челны (8552)20-53-41  
Нижний Новгород (831)429-08-12  
Новокузнецк (3843)20-46-81  
Ноябрьск (3496)41-32-12  
Новосибирск (383)227-86-73  
Ноябрьск (3496)41-32-12  
Омск (3812)21-46-40  
Орел (4862)44-53-42  
Оренбург (3532)37-68-04  
Пенза (8412)22-31-16  
Петрозаводск (8142)55-98-37  
Псков (8112)59-10-37

Пермь (342)205-81-47  
Ростов-на-Дону (863)308-18-15  
Рязань (4912)46-61-64  
Самара (846)206-03-16  
Саранск (8342)22-96-24  
Санкт-Петербург (812)309-46-40  
Саратов (845)249-38-78  
Севастополь (8692)22-31-93  
Симферополь (3652)67-13-56  
Смоленск (4812)29-41-54  
Сочи (862)225-72-31  
Ставрополь (8652)20-65-13  
Сыктывкар (8212)25-95-17  
Сургут (3462)77-98-35  
Тамбов (4752)50-40-97

Тверь (4822)63-31-35  
Тольятти (8482)63-91-07  
Томск (3822)98-41-53  
Тула (4872)33-79-87  
Тюмень (3452)66-21-18  
Улан-Удэ (3012)59-97-51  
Ульяновск (8422)24-23-59  
Уфа (347)229-48-12  
Хабаровск (4212)92-98-04  
Чебоксары (8352)28-53-07  
Челябинск (351)202-03-61  
Череповец (8202)49-02-64  
Чита (3022)38-34-83  
Якутск (4112)23-90-97  
Ярославль (4852)69-52-93

Киргизия (996)312-96-26-47

Россия (495)268-04-70

Казахстан (772)734-952-31

<https://bongard.nt-rt.ru> || [bdi@nt-rt.ru](mailto:bdi@nt-rt.ru)

# КАТАЛОГ



## MIXING

Mixing preparation

L

Fonto

Dox-Domix 30

Spiral mixers

Spiral EvO

Spiral A

Spiral EvO TH-TL

Twin arm mixer

Calypso

Bowl tilter

Tilti

BDC

Planetary mixers

Saturne 3

Stellar

## MACHINES

Dough division

Eris

Mira

Concorde 4

Mercure 4

Divimach

Pre-rounding Rounder

BLP

BC

Intermediate proofing

RP

Mada 2 manual

Mada 2 semi-auto

Medio SA 10 - 12

Medio FA 10-12

IK

Moulding

Major

TE

Automatic group

Medio 900 p/h

Medio 1200 p/h

Paneotrad®

Paneotrad

Accessories

Rhea

## FREEZING

Proofing cabinet

BFA

BFM

BFC

BFE

Proofing accessories

Blast freezer Conserv. unit

BSP

KRYO+

BSC

KRYO

Boreal positive

Boreal negative

Boreal Paneo

Refrigerated Workbench

BTP

Controls

Zephyr

## OVENS

Rack ovens

6.43 E - MG

8.43 FE

8.43 E - MG

10.83 E - MG

8.64 E - MG

8.84 E - MG

12.84 MG

CERVAP

Compact Compact GME

RS

600 750

DT 600 DT 750

XT

XL

GME

ORION

Orion EvO 1x800

Orion EvO 2x800

Orion EvO 2x600

Accessories deck oven

Accessories

Loader-un-loader 600

Loader-un-loader 750

Loader-un-loader 800

Modular ovens

Soleo EvO

Soleo

Convection ovens

Alcor

Krystal

Premio

combination ovens



Water cooler L 90

L

## Water cooler with water storage

### Performances

- Effective tank volume : 90, 120, 250 or 400 litres (depends on model)
- Water capacity per hour: from + 20 °C to +1°C : 50, 120, 180 or 300 litres (depends on model).

### The advantages

- Water is always available at constant temperature
- Energy savings through built-in low energy consumption compressor
- Easy to use
- Display of the water level on the cooler depending on the model
- Compact size
- Practical installation

### Use

The water cooler L is designed to cool the water used for mixing the dough.

### Operating principle

The water, stored in a tank is cooled by a R452 A refrigerating gas coil. A thermostat controls the water temperature to the nearest 10th of a degree and a ballcock permanently controls the water level. Water is then evacuated either by gravity or a water pump (optional) on the L90 and L120 models or by a built-in draft pump on the L250 and LE400 models.

### Construction

- Complete control panel with thermostat and thermometer
- Food-grade stainless steel coil
- 18/10 stainless steel tank, food-grade, with injected polyurethane foam
- High power integral refrigeration unit (except LE 400 GD)
- Heat exchange accelerated by stirrer
- Regulated by thermostatic pressure valve
- Self-fixing modular cladding for easy installation and maintenance
- Manual measuring of water by quick, easy-to-read level tube on L 90 and L 120 models
- All steel body
- Optional pump on L 90 and L 120, standard on L 250 and L E 400
- Power supply: single phase 230 V 50 Hz (on Standard for L90-L120 and L250 models) 400V 3 PH+N 50/60 Hz for LE 400 model

### ■ Important note :

The « chair » option is highly recommended for ease of installation and maintenance.

# Water cooler with water storage L

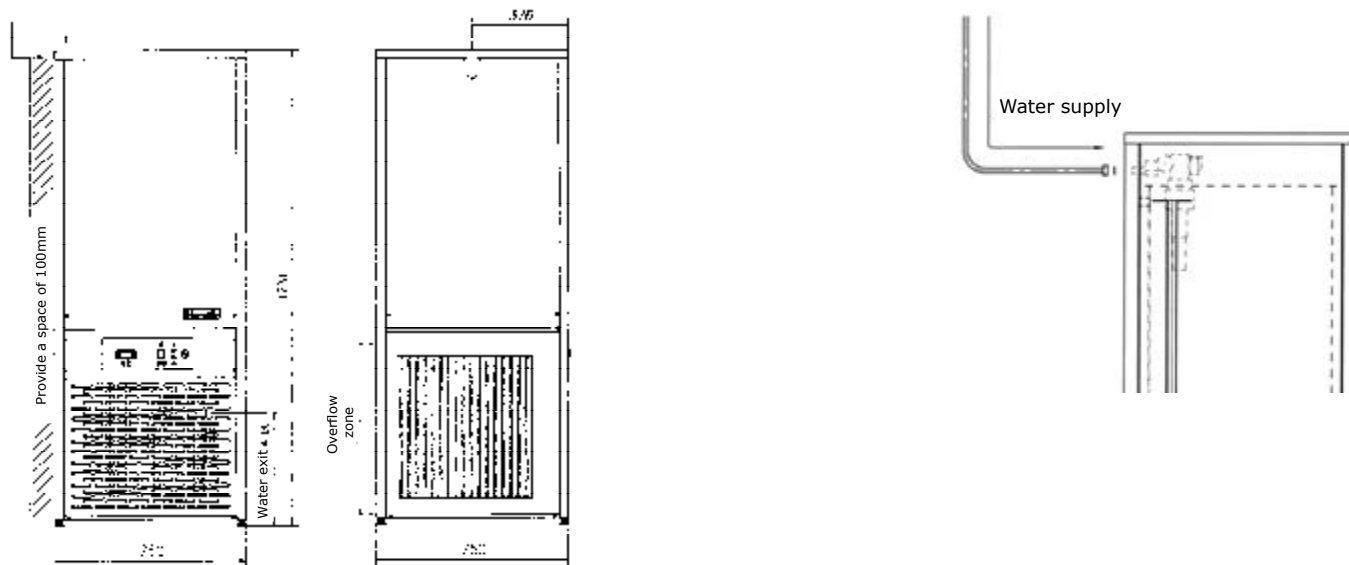

Model
L 90
L 120
L 250

Accessories
Pump unit L 90 - L 120
Stands L 90 - L 120
Stand L 250

General features							
Model		L 90	L 120	L 250	Stands dimensions only for Pump unit only models L 90-L 120 L 250 for L 90 - L 120		
<b>Maximum output per hour</b>							
+ 20°C - + 1°C	(l/h)	50	90	180	0	0	0
+ 18°C - + 3°C	(l/h)	90	120	250	0	0	0
<b>Volume</b>							
Effective tank volume	(litre)	90	120	250	0	0	0
Tank volume	(litre)	100	130	265	0	0	0
<b>Power</b>							
Refrigerating power -10°C	(kW)	1,2	1,9	3,1	0	0	0
Connecting power	(kW)	0,4	0,75	2	0	0	0,3 kW - 2,7 A
Power supply		Single phase 230 V - 50 Hz					Single phase 230 V - 50 Hz
<b>Dimensions and weight</b>							
W x D	(mm)	540 x 570	540 x 570	750 x 750	540 x 580	770 x 770	0
Height	(mm)	1160	1380	1731	1015	500	0
Net weight	(kg)	80	110	230	12	10	25
Weight with water	(kg)	180	240	495	0	0	0

Packing		Model	L 90	L 120	L 250	pump group
Mainland (Cardboard box on palett)	Width	(mm)	650	650	780	550
	Lenght	(mm)	600	600	810	250
	Height	(mm)	1300	1520	1850	400
	Weight	(kg)	92	122	250	28
By Sea (Wooden Crate)	Model		L 90	L 120	L 250	pump group
	Width	(mm)	750	750	810	550
	Lenght	(mm)	720	720	870	250
	Height	(mm)	1390	1580	1900	400
	Weight	(kg)	160	185	280	30





## « ICE » Water cooler with continuous flow

### Performances

- Water capacity per hour: from + 20 °C to +3°C: 45, 60, 90, 120 or 180 litres depending on models.

### The advantages

- Better hygiene: the chilled water cannot be contaminated and is not in contact with ambient air
- No accumulation of cooled water
- No water pump required
- Use of the tap water at natural pressure
- Cold reserve by simple or double water tank, depending on the model chosen

### Use

The water cooler Fonto is designed to cool the water used for mixing the dough.

### Operating principle

The tapwater flows through a sealed circuit, itself located in a tank cooled by the creation and accumulation of ice. The variation of the block of ice is controlled by a probe that guarantees constant cooling. The water cooler can be composed of one or two cooling tanks.

### Construction

- Evaporator made of copper tubes
- Food grade stainless steel exchanger
- High power integrated freezing compressor
- 2 or 3 stirrers, depending on model, for accelerating the freezing exchange
- Functioning control: the thickness of ice is measured by a probe
- Stainless steel finish
- 1 tank for Fonto 45, 60 and 90 models
- 2 tanks and 2 different refrigerating circuits for Fonto 120 and 180
- Power supply: single phase 230 V 50 Hz

### ■ Important note:

While using a wall-mounted support, it is recommended (depending on quality of the wall) to use "M8" type threaded rods or chemical sprigs.

The 45 or 60 models and the wall-mounted support have to be screwed together with 8 "M8" rods (not supplied).

Important: it is necessary to check the strength of the flagstone which supports the heavier models before placing the Fonto on the upper floor.

## Fonto water cooler with continuous flow

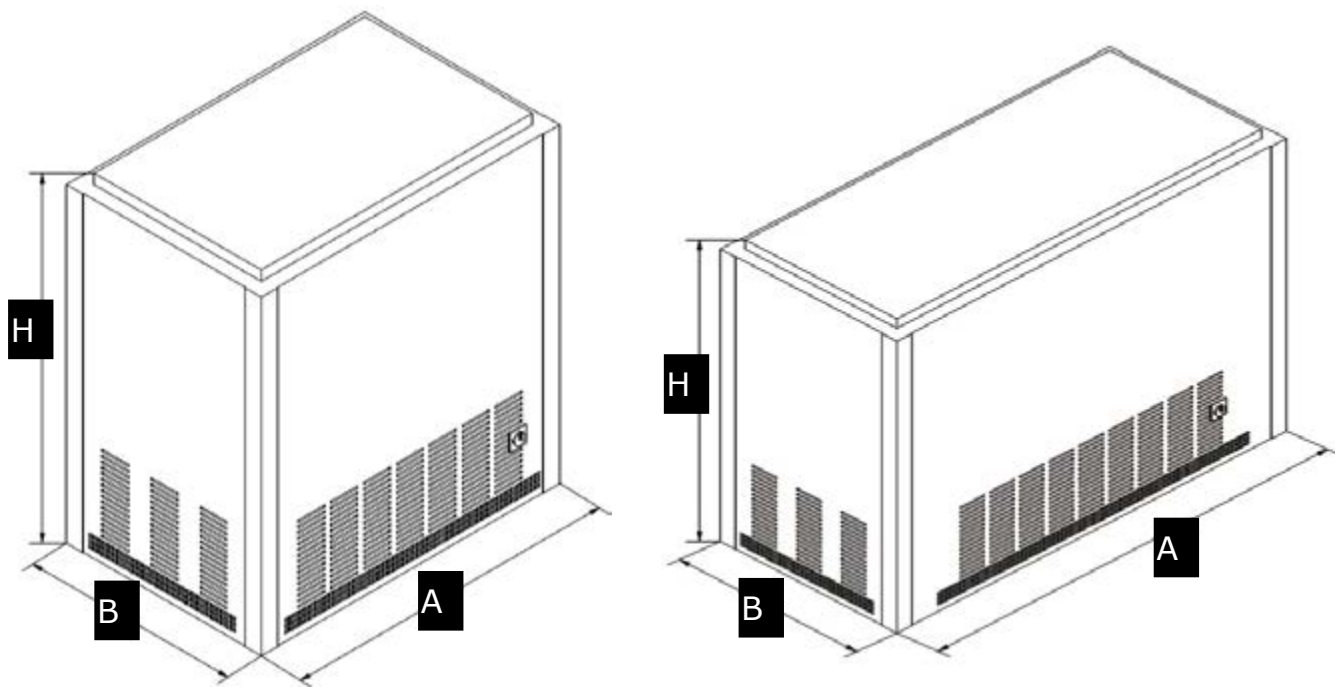

### Stands (height 500 mm)

Fonto 45
Fonto 60
Fonto 90
Fonto 120
Fonto 180
Wall-mounted support for Fonto 45 or Fonto 60

### Connecting

Water pressure required maxi.	3 Bars
Water inlet	Threaded wall mounted connection diam 1/2"
Water outlet	PVC Ø 40 mm

### General features

Models		Fonto 45	Fonto 60	Fonto 90	Fonto 120	Fonto 180
Water output	(l/min)	8	8	8	7	7
From + 20°C to + 1°C	(l/h)	-	-	-	120	180
From + 20°C to + 3°C	(l/h)	45	60	90	-	-
<b>Volume</b>						
Tank volume		140	140	250	140 + 55	250 + 75
Stirrers		2	2	2	3	3
Bowl		1	1	1	2	2
<b>Power</b>						
Refrigerating power at -10°C	(kW)	0.6	0.7	1.5	0.6 + 0.4	1.5 + 0.5
Connecting power Single PH 230 V - 50 Hz	(kW)	0.5	0.7	0.9	1.0	1.2
<b>Dimensions and weight</b>						
A x B	(mm)	950 x 590	950 x 590	995 x 720	1305 x 590	1504 x 720
H	(mm)	975	975	1135	975	1135
Net weight	(kg)	110	110	175	175	225
Weight with water	(kg)	250	250	425	370	550

### Packing

#### Mainland (Cardboard box on pallet)

Model		Fonto 45	Fonto 60	Fonto 90	Fonto 120	Fonto 180
width	(mm)	680	680	800	680	820
length	(mm)	970	970	1060	1370	1590
Height	(mm)	1220	1220	1370	1220	1400
Weight	(kg)	130	130	170	220	245
Model		Fonto 45	Fonto 60	Fonto 90	Fonto 120	Fonto 180
width	(mm)	780	780	900	780	910
length	(mm)	1070	1070	1160	1470	1640
Height	(mm)	1270	1270	1420	1270	1550
Weight	(kg)	150	150	190	190	260

#### By Sea (Wooden Crate)

# Dox-Domix



Dox 30



Domix 30

## Water meter & mixer

### Performances

Water output:

- From 15 to 25 l/min with 1 bar and 20°C
- From 35 to 55 l/min with 5 bars and 20°C

### The advantages

- Optimised management of the temperature and outflowing water quantity.
- Digital display of information
- Contributes to consistent dough mixing results
- Easy start-up

### Use

The Dox-Domix water meter & mixer range doses and mixes (except for the Dox 30) the precise quantity and hot and/or cold water temperature needed for the dough. The water temperature is measured and displayed directly on a monitor.

### Operating principle

The water meter & mixers are connected to the main water, hot water and water cooler. Depending on the selected programme, they determine the quantity and ideal temperature of water needed for the recipe. The mix water is obtained using a thermostatic button.

### Construction

- Electronic control
- Composite structure (4 / 5 mm thick)
- Dual layer stainless steel filter
- Back flow valve
- Power plug and jack for remote pump control
- Stainless steel delivering pipe
- Delivered with «S» pipe, 2.5m pipe and support
- Digital keyboard to set or call up memory, or water discharge
- Power supply : single phase 208 to 240 V, 50 Hz to 60 Hz (on Standard models)

### Dox 30

- Display of quantity and temperature of water 1/10 of a degree Celsius

### Domix 30

- Display of quantity and temperature of water 1/10 of a degree Celsius
- Temperature adjustment by means of a thermostatic button

# Dox - Domix Water meter & mixer

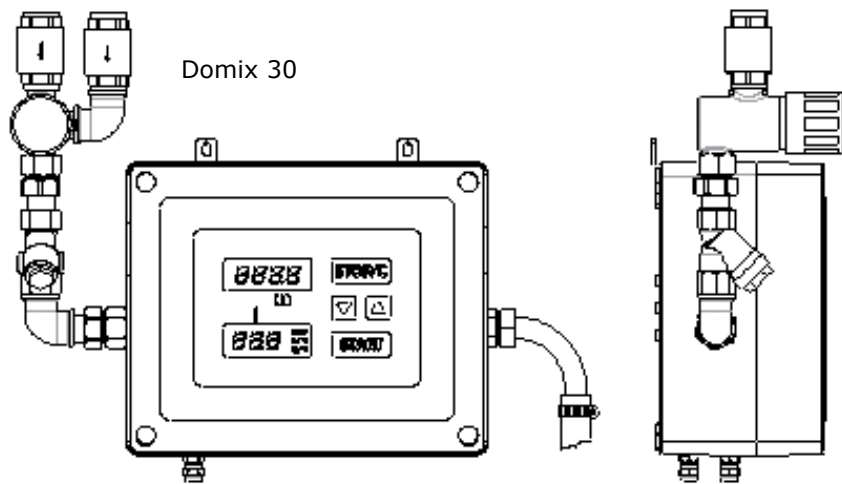

## Water cooler and water meter & mixer connecting principle Do not connect the water supply on the water softener

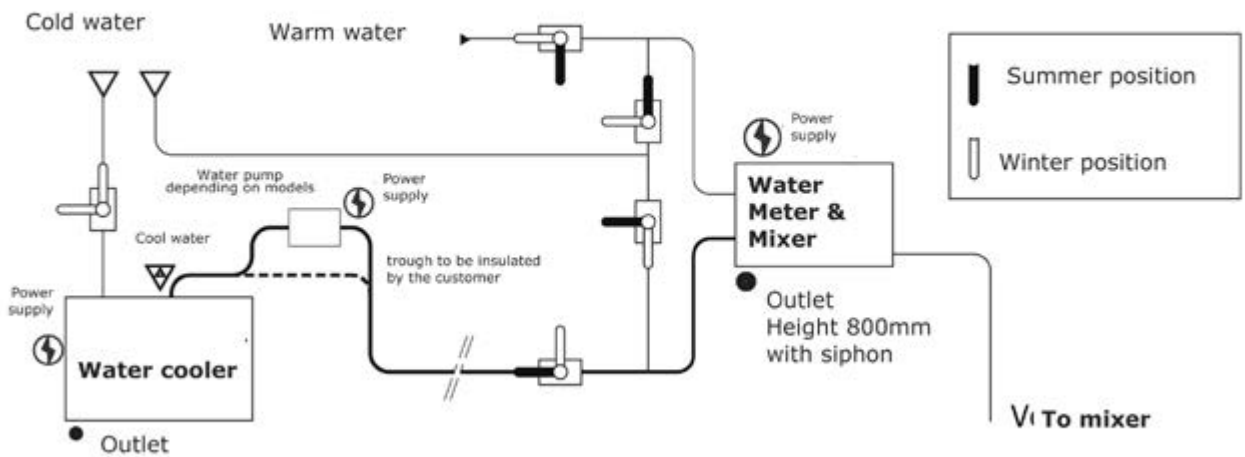

General features		
Model	Dox 30	Domix 30
Metering function	Yes	Yes
Mixing function	No	Yes
Pump micro-switch	Yes	Yes
Cold water inlet	Yes	Yes
Hot water inlet	No	Yes
Water pressure required (bar)	0,5 - 5	1 - 5
Net weight (kg)	8	9
Output		
Water output with 1 bar and 20° C in litre/minute	25	15
Water output with 5 bars and 20° C in litre/minute	55	35
Power (W)	25	25

Packing				
Mainland (Cardboard box on palett)	Model		Dox 30	Domix 30
	width	(mm)	480	480
	length	(mm)	550	550
	Height	(mm)	290	290
	Weight	(kg)	10	10
By Sea (Wooden Crate)	Model		Dox 30	Domix 30
	width	(mm)	520	5420
	length	(mm)	590	590
	Height	(mm)	330	330
	Weight	(kg)	12	12

# Spiral Evo



## Spiral mixers with fixed bowl

### Capacity

- Flour: from 1,2 kg to 125 kg
- Dough: from 2 kg to 200 kg
- Pouring: from 0,8 litre to 75 litres

### Use

Mixing is the 1st bread-making operation. It consists of mixing the ingredients in order to create a dough.

For professional use, Spiral mixers « Spiral Evo » are suitable for all types of dough.

### Operating principle

Products of the Spiral Evo range are essential instruments to make a perfect dough. They work with two rotating speeds : the first corresponds to the mixing phase (mixing and formation of a dough). The second allows the stretching and the oxygenation of the dough. The different controls offer the possibility of a manual use (electromechanical: typ M) or (electronical: typ E).

### Construction

- Stainless steel arm, bowl and dividing blade
- Thermoformed anti-shock ABS top cover
- Thermoformed transparent PMMA cover scratch resistant
- The outer casing of the frame is painted with an anti-corrosion epoxy powder coating compatible with food contact. A cataphoresis treatment is available as option
- Mixing time setting for 1st and 2nd speed
- Spiral Evo 50 and 70 have a single common motor for bowl and spiral
- The other models are equipped with two motors : one for the bowl and one for the spiral
- Power supply : 3N~ 400 V 50Hz
- All spiral mixers are equipped with locking mechanism to retain the cover from the Spiral Evo 80 model and for all models of higher capacity

### Standard model

- Type E : Electronical control panel with high resistant membrane keys proposing a new special Paneotrad program (Use: See « Control panel Spiral Evo» in the catalogue)
- see-through and anti-spray safety cover

### Optional

- Stainless steel safety grid in addition to the see-through safety cover (only with type E control)
- Type M: electromechanical control panel with pushbuttons and timers (operation: see «Spiral EVO controls» in the catalogue)
- Infrared temperature sensor (only with control Type E)

### The advantages

- Mixing quality:
  - Control of dough heating
  - Constant quality, whatever the amount of dough in the bowl
  - Better dough oxygenation
- Ergonomics:
  - Low noise
  - Cover retention system
  - Easy cleaning
  - Intuitive operation
- Work on small kneaded
- Versatile: suitable for all types of dough
- New mode dedicated to Paneotrad (type E)



## Spiral Evo Spiral mixers with fixed bowl

	Spiral Evo 50	Spiral Evo 70	Spiral Evo 80	Spiral Evo 110	Spiral Evo 150	Spiral Evo 200	Spiral Evo 250	Spiral Evo 300
<b>Type of bowl</b>								
Fixed	■	■	■	■	■	■	■	■
<b>Control</b>								
Electronical (type E)	■	■	■	■	■	■	■	■
Manual mode special Paneotrad (only type E)	■	■	■	■	■	■	■	■
Temperature control (only type E)	€	€	€	€	€	€	€	€
Electromechanical 2 timers (type M)	€	€	€	€	€	€	€	€
<b>Cover</b>								
See-through cover lid	■	■	■	■	■	■	■	■
See-through cover lid and Stainless steel safety grid	€	€	€	€	€	€	€	€
<b>Finishing</b>								
Stainless steel bowl	■	■	■	■	■	■	■	■
Frame casing coated with cataphoresis treatment	€	€	€	€	€	€	€	€
<b>Power supply</b>								
3N~ 400 V	■	■	■	■	■	■	■	■

### Capacity (indicative Values)

Model	Flour (kg)	Dough (kg)	Pouring (litre)	Total (litre)
Spiral Evo 50	1,2 - 20	2 - 30	0,8 - 12	50
Spiral Evo 70	1,5 - 30	2,5 - 45	1 - 15	70
Spiral Evo 80	1,8 - 40	3 - 60	1,2 - 20	80
Spiral Evo 110	2,2 - 50	3,5 - 80	1,3 - 30	110
Spiral Evo 150	2,5 - 62,5	4 - 100	1,5 - 37,5	150
Spiral Evo 200	2,5 - 80	4 - 130	1,5 - 50	200
Spiral Evo 250	2,8 - 100	4,5 - 160	1,7 - 60	250
Spiral Evo 300	2,8 - 125	4,5 - 200	1,7 - 75	300

Model	Total power (kW)	Net weight (kg)	Spiral speed 50Hz (rpm)	Bowl speed 50Hz (rpm)	Spiral speed 60Hz (rpm)	Bowl speed 60Hz (rpm)
Spiral Evo 50	1,5	218	100 - 200	10 - 20	100 - 200	10 - 20
Spiral Evo 70	1,5	225	100 - 200	10 - 20	100 - 200	10 - 20
Spiral Evo 80	2,57	360	100 - 200	7 - 14	100 - 200	7 - 14
Spiral Evo 110	4,55	417	103 - 207	7.5 - 15	103 - 207	7.5 - 15
Spiral Evo 150	4,55	417	103 - 207	7.5 - 15	103 - 207	7.5 - 15
Spiral Evo 200	6,8	630	103 - 207	10 - 20	103 - 207	10 - 20
Spiral Evo 250	8,4	705	103 - 207	10 - 20	103 - 207	10 - 20
Spiral Evo 300	8,4	705	103 - 207	10 - 20	103 - 207	10 - 20

# Spiral Evo Spiral mixers with fixed bowl

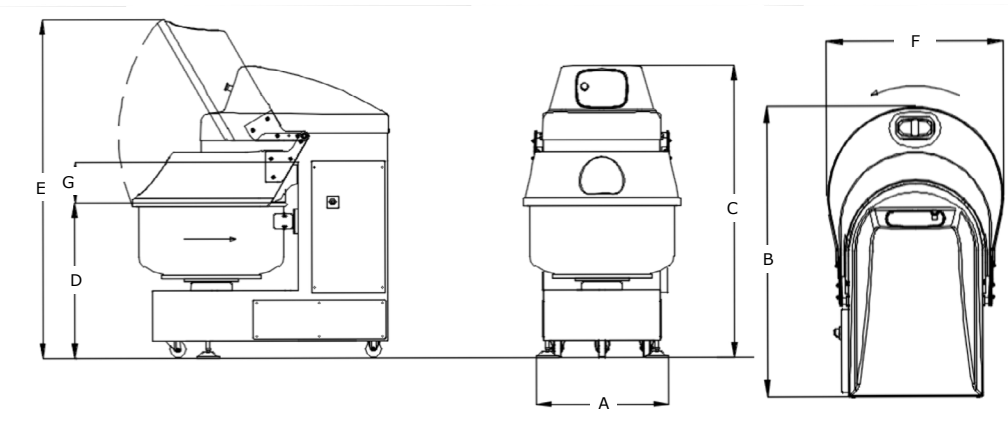

Model	Dimensions (mm)						
	A	B	C	D	E	F	G
Spiral EvO 50	477	1000	1370	741	1892	590	181
Spiral EvO 70	477	1000	1370	791	1892	590	131
Spiral EvO 80	565	1150	1550	911	1705	675	153
Spiral EvO 110	588	1250	1560	886	1795	771	188
Spiral EvO 150	588	1250	1560	936	1795	771	138
Spiral EvO 200	735	1450	1630	870	1890	875	224
Spiral EvO 250	735	1530	1620	881	1995	980	203
Spiral EvO 300	735	1530	1620	941	1995	980	143

Packing										
	Model		Spiral EvO 50	Spiral EvO 70	Spiral EvO 80	Spiral EvO 110	Spiral EvO 150	Spiral EvO 200	Spiral EvO 250	Spiral EvO 300
	Cardboard box on palett	Width	(mm)	1150	1150	1300	1300	1300	1600	1600
Length		(mm)	650	650	850	850	850	1000	1000	1000
Height		(mm)	1550	1550	1730	1730	1730	1750	1750	1750
Weight		(kg)	239	245	395	452	452	660	741	741
Wooden crate	Model		50	70	80	110	150	200	250	300
	Width	(mm)	1250	1250	1400	1400	1400	1700	1700	1700
	Length	(mm)	750	750	950	950	950	1100	1100	1100
	Height	(mm)	1670	1670	1820	1820	1820	1850	1850	1850
Perforated crate	Model		50	70	80	110	150	200	250	300
	Width	(mm)	1250	1250	1400	1400	1400	1700	1700	1700
	Length	(mm)	750	750	950	950	950	1100	1100	1100
	Height	(mm)	1670	1670	1820	1820	1820	1850	1850	1850
	Weight	(kg)	323	327	556	613	614	765	846	847

# Control panel Spiral Evo



Electromechanical control panel Spiral Evo Type M for models 80 and more



Electromechanical control panel Spiral Evo Type M for models 50-70



Electronic control panel for Spiral Evo type E

## Control for spiral mixers

New special  
Panoetrad  
mode

### The advantages

- Manual or automatic cycle
- Setting of 1st and 2nd speed
- Optimized control of the recipes
- A specific Panoetrad work mode
- Audible sound signal at the end of the cycle
- 3 operating modes available with the temperature sensor

### ■ Electronic control panel – Spiral Evo type E

#### Use

- 9 mixing programs are available
- A complementary program: program 0 keeps in memory the last set value
- Electronic controls with digital display and high resistance membrane keyboard
- Classic manual mode
- Special Panoetrad mode
- Electronic controls can memorise times used in 1st and 2nd speeds
- Times can be changed without stopping the mixer
- Buzzer sounds on completion of the mixing cycle
- Inversion of rotation of the bowl during the mixing, except models 50 and 70

#### Characteristics of control panel type E

Manual mode : used to test the mixing time of a recipe before programming it. One can program up to 9 recipes.

Automatic mode : is used to launch the different recipes.

The times decrease and the change from 1st into 2nd speed happens automatically.

-With the Panoetrad mode, it is possible to adapt the mixing of panoetrad recipes that need resting time such as autolyse and bulk fermentation. With this specific mode «P», the baker can program up to 8 different recipes. the cycle runs automatically, including the resting time, without any intervention. the panoetrad mode can be use in automatic or manual mode.

- With the infrared temperature sensor option, you know the temperature of the dough at any time. With this option (only available with the type E control), you can also program a temperature limit that must not be exceeded for your different programs. Once this limit has been exceeded and according to your preference:

- The temperature display may blink
- There may be an audible sound signal, to warn the baker from an overshooting of the set dough temperature
- Programm the end of mixing once the set temperature limit is reached.

### ■ Electro-mechanical control panel - Type M

#### Use

- 1st and 2nd speed timers adjustable before start
- Manual and automatic modes
- Automatic cycle for the passage from 1st to 2nd speed
- End-of-cycle sound signal
- Inversion of the rotation of the bowl, except for models 50 and 70

#### ■ ■ ■ Important notes :

If the mixer is fitted with the see through anti-splash lid, it is possible to start mixing in 2nd speed. When fitted with a grid, to comply with the CE norm, the 1st speed time setting can not be less than 2 minutes.

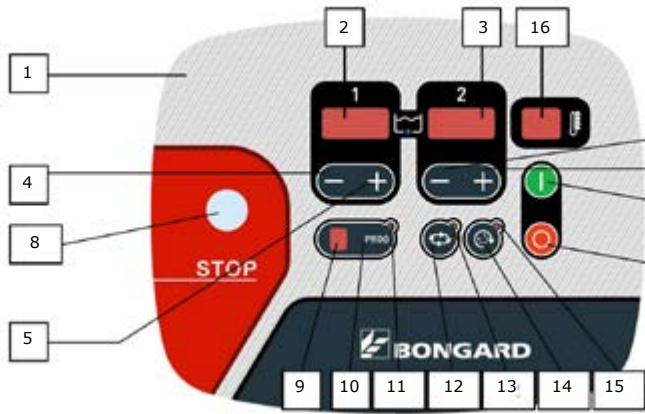

- ① Control panel
- ② Time display 1st speed
- ③ Time display 2nd speed
- ④ Decrease the time of the 1st speed
- ⑤ Increase the time of the 1st speed
- ⑥ Decrease the time of the 2nd speed
- ⑦ Increase the time of the 2nd speed
- ⑧ Emergency/Stop button
- ⑨ Visual mode selected («0 to 9 or» H «)
- ⑩ Program selection button
- ⑪ Red Led Programming
- ⑫ Auto or manual mode activation button
- ⑬ Red Led «current mode»
- ⑭ Touch:  
- rotation of the bowl with open cover  
- Inversion direction of rotation during mixing
- ⑮ Led red signaling reversal of movement
- ⑯ Temperature display of kneading
- ⑰ Start button
- ⑱ Stop button

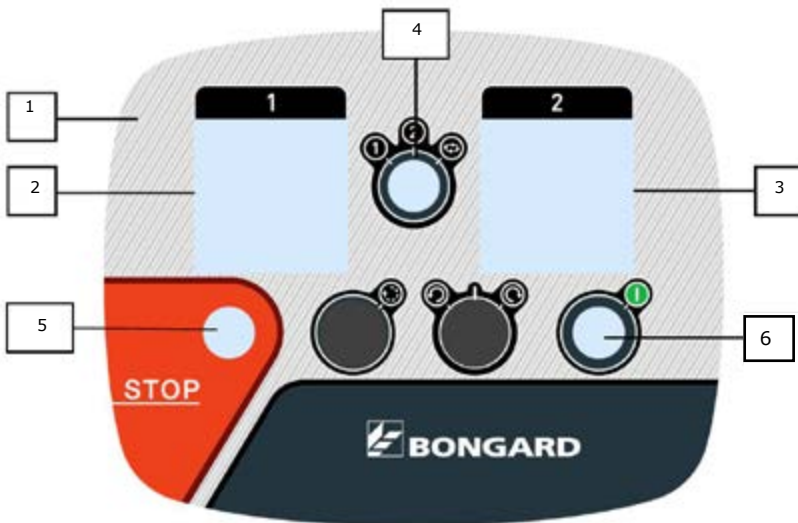

- ① Control panel
- ② 1st Speed Timer
- ③ 2nd speed timer
- ④ Selector to activate:  
- V1 runs continuously  
- V2 runs continuously  
- Adjust with the timer
- ⑤ Emergency/Stop button
- ⑥ On Button

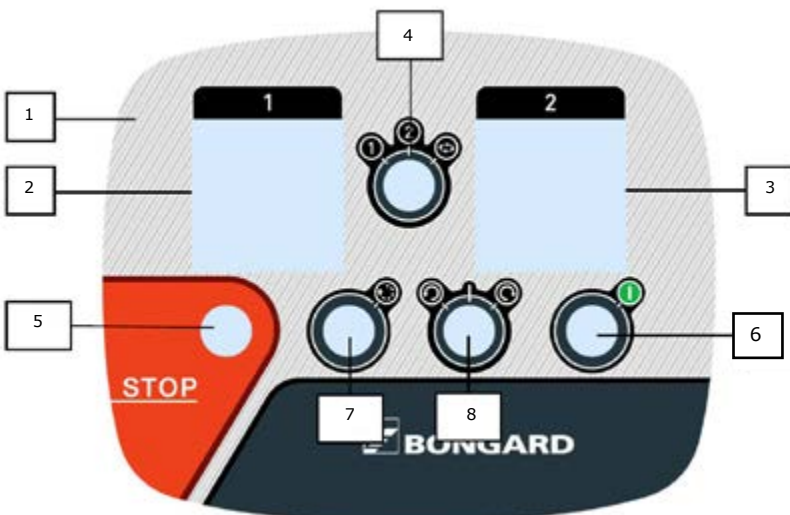

- ① Control panel
- ② 1st Speed Timer
- ③ 2nd speed timer
- ④ Selector to activate:  
- V1 runs continuously  
- V2 runs continuously  
- Adjust with the timer
- ⑤ Emergency/Stop button
- ⑥ On Button
- ⑦ Tank rotation
- ⑧ Direction of rotation of the tank

# Spiral A



## Removable bowl Spiral mixer

### Performances

- Flour capacity : from 5 to 158 kg
- Dough capacity : from 8 to 253 kg
- Bowl volumes : from 250 to 360 litres depending on models.

### The advantages

- 2 mixing speeds
- Inversion of the rotation direction of the bowl in 1st speed
- Adaptability to Bongard hydraulic hoists (Tilti and BDC) (Attention : for any installations with an existing EBCV bowl lifting & tilting hoist, an adaptor kit is needed (ref. 2B001042).
- Allows to mix small quantities of dough
- A choice of 2 electronic

### Use

Mixing is the 1st bread-making operation that blends the raw materials to make the dough. Bongard spiral kneaders Spiral A with removable bowl are used in the manual mixing process including following phases : mixing the ingredients in a dough mass, cutting the dough for homogenization, consistency, softness and elasticity, stretching and oxygenation to improve dough whiteness, increase its extensibility and fineness. For professional use, they are ideal for all types of dough.

### Operating principle

The different ingredients are placed in the mixing bowl. The 1st speed is used for initial blending of ingredients. The 2nd speed is used to cut, stretch and air the dough. The different controls offer the possibility of manual or automated management. The bowl can be removed from the structure to add ingredients and for use with a Bongard bowl lifting & tilting hoist.

### Construction

- Reinforced rigidified steel structure with external structure coated with epoxy (food grade)
- Front surface of head and body coated with stainless steel protective layer
- Structure mounted on 6 feet for easy cleaning
- Lower edge of stainless steel bowl specially shaped with «almond-shaped beading» to provide better coupling between the driving system and the bowl
- Bowl strengthened by a welded flat strip
- Stainless steel arm, bowl and dividing blade
- Easy fitting and removal of the bowl using the hydraulic head lifting mechanism
- Bowl pre-connection device makes it easy to fit the machine on an uneven surface
- Friction wheel transmission for the bowl drive
- Belt and pulley transmission
- Power supply : 400V 3 PH+N 50/60 Hz

### Models :

#### Safety see-through lid for a better reduction of flour dust

- Electronic control « basic mode » : same function as Spiral control type E
- Electronic control « advanced mode » : large LCD display, possibility to manage, memorize and save by name 99 recipes, signal for malfunction, variable rotation speeds (+ or -10%)

Options available : Infrared temperature probe, Ingredient containers

- Electronic control « basic mode » : see description above
- Electronic control « advanced mode » : see description above



# Spiral A Removable bowl spiral mixer

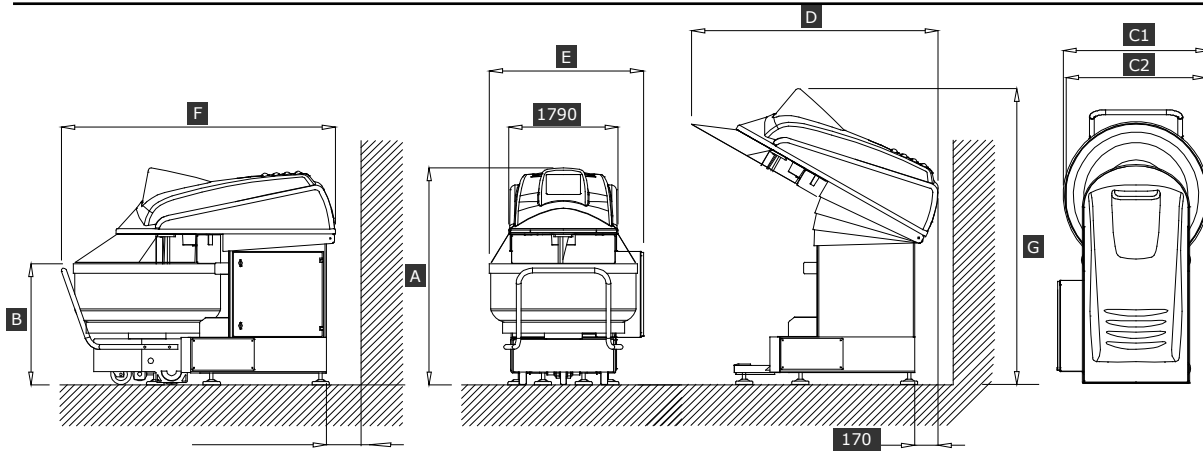

Capacity : mixer and/or additional bowl for models (indicative values)

Model	Flour (kg)	Dough (kg)	Pouring (litre)	Total litre
Spiral A 250	5 - 100	8 - 160	3 - 60	250
Spiral A 300	5 - 125	8 - 200	3 - 75	300
Spiral A 360	7 - 158	11 - 253	4 - 95	360

Model	Total power (kW)	Net weight (kg)	Arm speed 50 Hz (rpm)	Bowl speed 50 Hz (rpm)	Arm speed 208 / 220 V 60 Hz (rpm)	Bowl speed 208 / 220 V 60 Hz (rpm)
Spiral A 250	10	1210	107 - 214	12,9	107 - 214	12,9
Spiral A 300	10	1210	107 - 214	12,9	107 - 214	12,9
Spiral A 360	13,6	1265	107 - 214	12,9	107 - 214	12,9
Bowl 250	-	280	-	-	-	-
Bowl 300	-	295	-	-	-	-
Bowl 360	-	325	-	-	-	-

Model	Dimensions (mm)							
	A	B	C1	C2	D	E	F	G
Spiral A 250	1064	865	930	900	1790	1045	1860	2190
Spiral A 300	1604	927	930	900	928	1045	1860	2190
Spiral A 360	1604	895	1080	1045	1075	1120	1980	2190
Bowl 250	-	865	930	900	-	-	-	-
Bowl 300	-	927	930	900	-	-	-	-
Bowl 360	-	895	1080	1045	-	-	-	-

Packing					
Mainland (Cardboard box on pallet)	Model		<b>Spiral 250</b>	<b>Spiral 300</b>	<b>Spiral 360</b>
	width	(mm)	1250	1250	1400
	length	(mm)	2050	2050	2200
	Height	(mm)	1800	1800	1800
	Weight	(kg)	1300	1300	1400
By Sea (Wooden Crate)	Model		<b>Spiral 250</b>	<b>Spiral 300</b>	<b>Spiral 360</b>
	width	(mm)	1350	1350	1500
	length	(mm)	2150	2150	2300
	Height	(mm)	1900	1900	1900
	Weight	(kg)	1400	1400	1500

# Control panel Spiral A



Electronic « Basic mode »  
control panel type E



Electronic « Advanced mode »  
control panel type LCD

## Electronic controls

### Electronic control panel « Basic mode » type E

#### Use

- 9 mixing programs are available
- Electronic controls with digital display and high resistance membrane keyboard
- Can be used in manual or automatic mode
- Electronic controls can memorise times used in 1st and 2nd gears
- Times can be changed without stopping the mixer
- Reverse bowl rotation available on all models except
- Buzzer sounds on completion of the mixing cycle

#### *Characteristic properties for control panel type E*

Manual mode : used to test the mixing time of a recipe before programming it. It is possible to program up to 9 recipes.

Automatic mode : used to start a program. Times are decremented then the mixer switches automatically from the 1st to the 2nd gear.

### Electronic control panel « Advanced mode » type LCD

#### Use

- programs available
- All functions and programs are displayed on an LCD screen.
- Electronic control with digital display and high resistance membrane
- Manual function
- Automatic function
- Two «favourite» program keys give direct access to the most frequently-used recipes
- Buzzer sounds on completion of the mixing cycle
- A 1st-gear reverse bowl rotation facility enables the user to mix small quantities

#### ■ Important notes :

If the mixer is fitted with the "see through" lid, it is possible to start mixing in 2nd speed. Fitted with a grid, to comply with the CE norm, the 1st speed will take at least 2 minutes

### The advantages

- Manual or automatic cycle
- Setting of 1st and 2nd speed
- Optimized control of the recipes
- Thanks to its "see through" lid, it is possible to start the mixing program in 2nd speeds

## Electronic control panel « Basic mode » type E

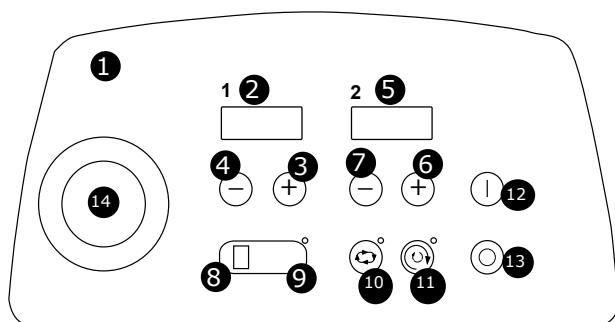

- 1 High resistance membrane keyboard
- 2 Display of the first speed
- 3 Increase the time of the first speed
- 4 Decrease the time of the first speed
- 5 Display of the second speed
- 6 Increase the time of the second speed
- 7 Decrease the time of the second speed
- 8 Display of the selected program
- 9 Selection of the program with key
- 10 Automatic or manual function with key
- 11 Function of reverse bowl rotation. Except the models Spiral 50 and 70
- 12 Start the cycle
- 13 Stop the cycle
- 14 Emergency/Stop button

## Electronic control panel « Advanced mode » type LCD

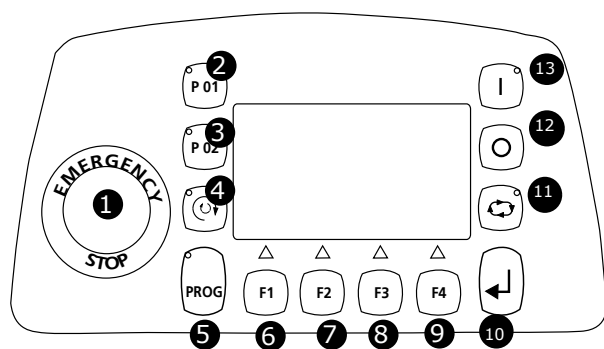

- 1 Emergency stop button
- 2 First program n° 1
- 3 First program n° 2
- 4 Inversion of the bowl rotation
- 5 Last recorded program recall
- 6 Multiple functions can be viewed on screen
- 7 Same function as n°6
- 8 Same function as n°6
- 9 Same function as n°6
- 10 Validation of programming choice
- 11 Manual cycle or Automatic cycle
- 12 Stop the cycle
- 13 Start the cycle

# Spiral Evo TH

Stainless steel grid  
option not available  
in EU



## Self-Tilting spiral mixer for volumetric divider

### Performances

- Flour capacity : from 2,5 to 125 kg
- Dough capacity : from 4 to 200 kg
- Bowl volumes : from 200 to 300 litres depends on models.

### The advantages

- Easy to use
- Reduced floor space
- 2 Models : with or without dough chute for DVM or DVP
- Safety "see-through" lid

### Use

Mixing is the 1st bread-making operation that blends the raw materials to make the dough. Bongard spiral kneaders Spiral Evo TH are used in the manual mixing process including following phases : mixing the ingredients in a dough mass, cutting the dough for homogenization, consistency, softness and elasticity, stretching and oxygenation to improve dough whiteness, increase its extendibility and fineness). For professional use, they are ideal for all types of dough.

### Operating principle

The different ingredients are placed in the mixing bowl. The 1st speed is used for initial blending of ingredients. The 2nd speed is used to cut, stretch and air the dough. The different commands offer the possibility of manual or automated management. The mixer, fixed on the movable part of the hydraulic hoist, is raised to transfer the dough into the hopper of a volumetric divider, on the right or on the left depending on models.

### Construction

- Stainless steel arm, bowl and dividing blade
- Thermoformed anti-shock ABS top cover
- Thermoformed transparent PMMA cover scratch resistant
- The outer casing of the frame is painted with an anti-corrosion epoxy powder coating compatible with food contact
- Mixing time setting for 1st and 2nd speed
- Spiral Evo range have a single common motor for bowl and spiral
- All models are equipped with two motors : one for the bowl and one for the spiral
- Power supply : 3N~ 400 V 50Hz
- All spiral mixers are equipped with locking mechanism to retain the cover

# Spiral Evo TH Self-Tilting spiral mixer

	Spiral Evo TH 200	Spiral Evo TH 300
<b>Bowl</b>		
Fixed	■	■
<b>Controls</b>		
Electronical (only)	■	■
Manual mode 'Paneotrad'	■	■
Temperature sensor	€	€
<b>Cover type</b>		
Transparent lid	■	■
Stainless steel grid only	□	□
<b>Bowl</b>		
Stainless steel bowl	■	■
<b>Accessorie</b>		
Dough chute	€	€
<b>Power supply</b>		
3N~ 400 V	■	■

<b>Capacity (indicative Values)</b>				
<i>Model</i>	<i>Flour (kg)</i>	<i>Dough (kg)</i>	<i>Pouring (litre)</i>	<i>Total (litre)</i>
Spiral Evo 200 TH	2,5 - 80	4 - 130	1,5 - 50	200
Spiral Evo 300 TH	2,8 - 125	4,5 - 200	1,7 - 75	300

<i>Models</i>	<i>Total power</i>	<i>Internal bowl diameter</i>	<i>Net Weight</i>	<i>Arm speed 50 Hz</i>	<i>Bowl speed 50 Hz</i>	<i>Arm speed 1st / 2nd speed 208 / 220 V 60 Hz</i>	<i>Bowl speed</i>
	<i>(kW)</i>	<i>(mm)</i>	<i>(kg)</i>	<i>(rpm)</i>	<i>(rpm)</i>	<i>(rpm)</i>	<i>(rpm)</i>
Spiral Evo 200 TH	7	800	1250	103 - 207	10 - 20	103 - 207	10 - 20
Spiral Evo 300 TH	8	900	1270		10 - 20		10 - 20

<b>Packing</b>				
Cardboard box on pallet	<b>Model</b>		<b>Spiral 200 TH</b>	<b>Spiral 300 TH</b>
	Width	(mm)	1900	1900
	Length	(mm)	2000	2000
	Height	(mm)	1850	1850
	Weight	(kg)	1300	1320
Wooden crate	<b>Model</b>		<b>Spiral 200 TH</b>	<b>Spiral 300 TH</b>
	Width	(mm)	1900	1900
	Length	(mm)	2000	2000
	Height	(mm)	2000	2000
	Weight	(kg)	1450	1470



# Spiral Evo TH Self-Tilting spiral mixer

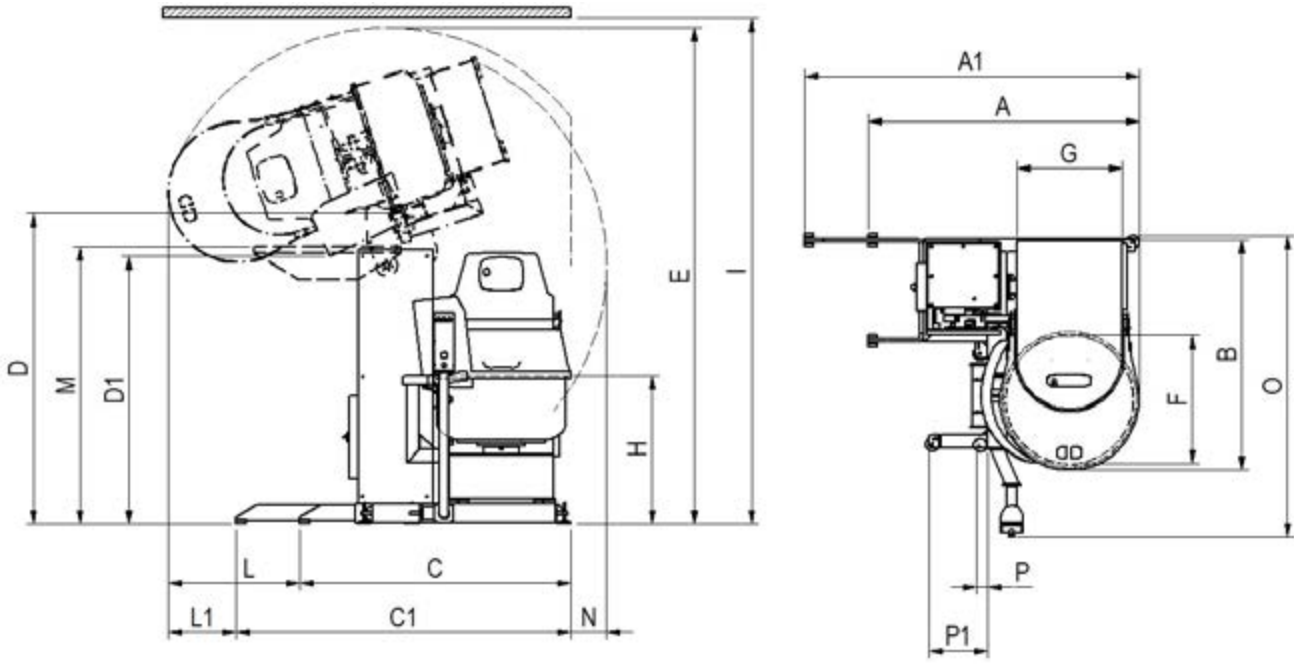

*Dimensions without dough chute (mm)*

	<i>A</i>	<i>B</i>	<i>C</i>	<i>D</i>	<i>E</i>	<i>F</i>	<i>G</i>	<i>H</i>	<i>I</i>	<i>L</i>	<i>M</i> ( <i>DVM</i> )	<i>M</i> ( <i>DVP</i> )	<i>N</i>	<i>O</i>	<i>P</i>
Spiral Evo 200 TH	1705	1430	1710	1940 ±	3090	800	660	930	3190	830	1690	1550	300	1880	70
Spiral Evo 300 TH	1760	1515	1710	1890 ±	3160	900	660	1000	3260	905	1690	1550	300	1880	70

*Dimensions with dough chute (mm)*

	<i>A1</i>	<i>B</i>	<i>C1</i>	<i>D1</i>	<i>E</i>	<i>F</i>	<i>G</i>	<i>H</i>	<i>I</i>	<i>L1</i>	<i>M</i> ( <i>DVM</i> )	<i>M</i> ( <i>DVP</i> )	<i>N</i>	<i>O</i>	<i>P1</i>
Spiral Evo 200 TH	2105	1430	2110	1670 ±	3090	800	660	930	3190	430	1690	1550	300	1880	370
Spiral Evo 300 TH	2160	1515	2110	1565 ±	3160	900	660	1000	3260	505	1690	1550	300	1880	370

# Spiral Evo TL

Stainless steel grid  
option not available  
in EU



## Tilting spiral mixer for work bench

### Performances

- flour capacity : from 3.5 to 125 kg
- Dough capacity : from 5.5 to 200 kg
- Bowl volumes : from 200 to 300 litres depends on models.

### The advantages

- Easy to use
- Reduced floor space
- 2 arm speed
- 2 separated motors
- Inversion of the rotation direction of the bowl
- Safety "see-through" lid on demand

### Use

Mixing is the 1st bread-making operation that blends the raw materials to make the dough. Bongard spiral kneaders Spiral Evo TL are used in the manual mixing process including following phases : mixing the ingredients in a dough mass, cutting the dough for homogenization, consistency, softness and elasticity, stretching and oxygenation to improve dough whiteness, increase its extendibility and fineness). For professional use, they are ideal for all types of dough.

### Operating principle

The different ingredients are placed in the kneading bowl. The 1st speed is used for initial blending of ingredients. The 2nd speed is used to cut, stretch and air the dough. The different controls offer the possibility of manual or automated management.

The mixer, fixed on the movable part of the hydraulic hoist, is raised to transfer the dough onto a workbench.

### Construction

- Stainless steel arm, bowl and dividing blade
- Thermoformed anti-shock ABS top cover
- Thermoformed transparent PMMA cover scratch resistant
- The outer casing of the frame is painted with an anti-corrosion epoxy powder coating compatible with food contact
- Mixing time setting for 1st and 2nd speed
- Spiral Evo range have a single common motor for bowl and spiral
- All models are equipped with two motors : one for the bowl and one for the spiral
- Power supply : 3N~ 400 V 50Hz
- All spiral mixers are equipped with locking mechanism to retain the cover

# Spiral Evo TL Self-Tilting spiral mixer

	Spiral Evo 110	Spiral Evo 150	Spiral Evo 200	Spiral Evo 300
<b>Bowl</b>				
Fixed	■	■	■	■
<b>Controls</b>				
Electronical (only)	■	■	■	■
Manual mode 'Paneotrad'	■	■	■	■
Temperature sensor	€	€	€	€
<b>Cover type</b>				
Transparent lid	■	■	■	■
Stainless steel grid only	□	□	□	□
<b>Bowl</b>				
Stainless steel bowl	■	■	■	■
<b>Power supply</b>				
3N~ 400 V	■	■	■	■

## Capacity (indicative Values)

Model	Flour (kg)	Dough (kg)	Pouring (litre)	Total (litre)
Spiral Evo 110 TL	2,2 - 50	3,5 - 80	1,3 - 30	110
Spiral Evo 150 TL	2,5 - 62,5	4 - 100	1,5 - 37,5	150
Spiral Evo 200 TL	2,5 - 80	4 - 130	1,5 - 50	200
Spiral Evo 300 TL	2,8 - 125	4,5 - 200	1,7 - 75	300

Models	Total power (kW)	Internal bowl diameter (mm)	Net Weight (kg)	Arm speed 50 Hz (rpm)	Bowl speed 50 Hz (rpm)	Arm speed 1st / 2nd speed 208 / 220 V 60 Hz (rpm)	Bowl speed (rpm)
Spiral Evo 110 TL	5	700	830	103 - 207	7,5 - 15	103 - 207	7,5 - 15
Spiral Evo 150 TL	5	700	830		7,5 - 15		7,5 - 15
Spiral Evo 200 TL	7	800	954		10 - 20		10 - 20
Spiral Evo 300 TL	8	900	1010		10 - 20		10 - 20

## Packing

	Model		Spiral Evo 110 TL	Spiral Evo 150 TL	Spiral Evo 200 TL	Spiral Evo 300 TL
Cardboard box on palett	Width	(mm)	1900	1900	1900	1900
	Length	(mm)	2000	2000	2000	2000
	Height	(mm)	1850	1850	1850	1850
	Weight	(kg)	800	800	1000	1060
Wooden crate	Model		Spiral Evo 110 TL	Spiral Evo 150 TL	Spiral Evo 200 TL	Spiral Evo 300 TL
	Width	(mm)	1900	1900	1900	1900
	Length	(mm)	2000	2000	2000	2000
	Weight	(kg)	1000	1000	1200	1250

# Spiral Evo TL Self-Tilting spiral mixer

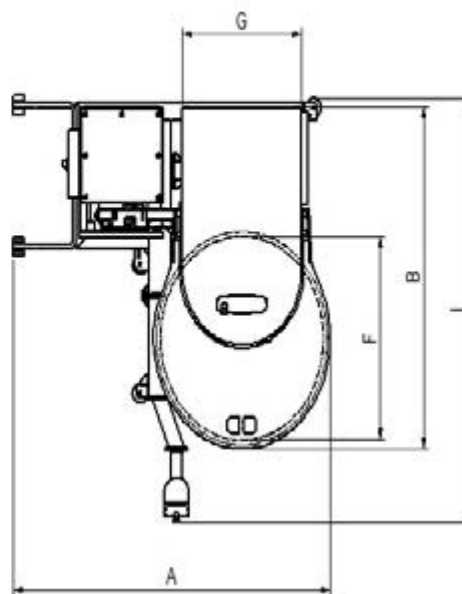
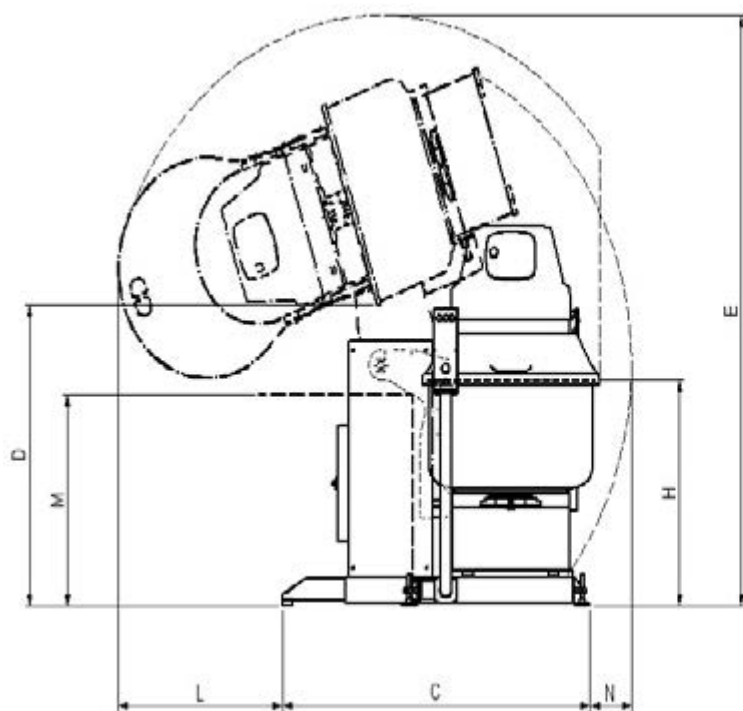

Models	Dimensions (mm)											
	A	B	C	D	E	F	G	H	I	L	M	N
Spiral Evo 110 TL	1605	1225	1707	1420 ±	2380	700	560	950	1650	660	900	200
Spiral Evo 150 TL	1605	1225	1707	1400 ±	2380	700	560	1000	1650	660	900	200
Spiral Evo 200 TL	1710	1430	1707	1430 ±	2545	800	660	930	1875	835	900	300
Spiral Evo 300 TL	1757	1515	1707	1350 ±	2615	900	660	1000	1875	910	900	300

# Calypso



## Twin-arm mixer

### Performances

- Dough: 5 to 64 kg
- Flour: 3 to 40 kg
- Water pouring: 2 to 24 L

### The advantages

- Suitable for all dough types thanks to its regulator
- Kneading very hydrated dough (up to 100% depending on the type of flour)
- Low aggressiveness
- Excellent oxygenation
- Control of dough heating
- Wide pouring range
- Lid retainer system
- Silent equipment
- Easy to use control

### Use

Mixing is the first step in the bread-making process. It consists of mixing the ingredients to create a dough.

The Calypso twin-arm mixer simulates the manual work of a craftsman. It guarantees excellent oxygenation and is gentle on the dough, while making this operation less restrictive.

Work is performed primarily in extension and in shear, allowing gentle kneading and above all without heating. The Calypso mixer is capable of kneading dough hydrated from 55 to 100%, depending on the type of flour and the process used.

Its use is strongly recommended when kneading a strongly hydrated dough. Indeed, the twin-arm mixer brings strength to the dough, making it easier to work.

### Operating principle

The movements of the twin articulated arms perfectly simulate the manual work of the craftsman. The dough is oxygenated and gluten matrix formation is optimised.

The left arm captures and raises the dough, while the right arm, with its two-tip mixer, stretches it.

The control equipped with a speed regulator makes it possible to control the number of movements per minute according to the degree of dough hydration (25 to 75 movements/minute).

### Construction

- Kneading speed regulator
- Stainless steel bowl and arms
- Stainless steel arms mounted on ball bearings
- Transparent lid made of scratch- and impact-resistant thermoformed PMMA
- Hydraulic hood retaining cylinder
- Two casters for easy movement and two fixed feet to ensure stability
- Mains voltage: 1N ~ 230V 50-60Hz or 3~ 400V 50-60Hz



## Calypso Twin-arm mixer

	CALYPSO 70	CALYPSO 80	CALYPSO 90
<b>Type of bowl</b>			
Fixed	•	•	•
<b>Control</b>			
Electronic with speed regulator (type EV)	•	•	•
<b>Cover</b>			
Transparent lid	•	•	•
Hydraulic hood retaining cylinder	•	•	•
<b>Bowl</b>			
Stainless steel bowl	•	•	•
<b>Supply voltage</b>			
1N~ 230V 50-60Hz	•	•	•
3~ 400V 50-60Hz	€	€	€
UL components	€	€	€

<b>Capacities (indicative values)</b>				
Model	Flour (kg)	Dough (kg)	Water pouring (L)	Total (L)
CALYPSO 70	3 - 30	5 - 48	2-18	70
CALYPSO 80	3 - 35	5 - 56	2-21	80
CALYPSO 90	3 - 40	5 - 64	2-24	90

These data are calculated on the basis of a 60% hydration level

Model	Total power (kW)	Net weight (kg)	Arm speed 50-60Hz (rpm/min)	Bowl speed 50-60Hz (rpm/min)
CALYPSO 70	1,5	320	30 - 70	6 - 14
CALYPSO 80		325		
CALYPSO 90		330		

# Calypso Twin-arm mixer

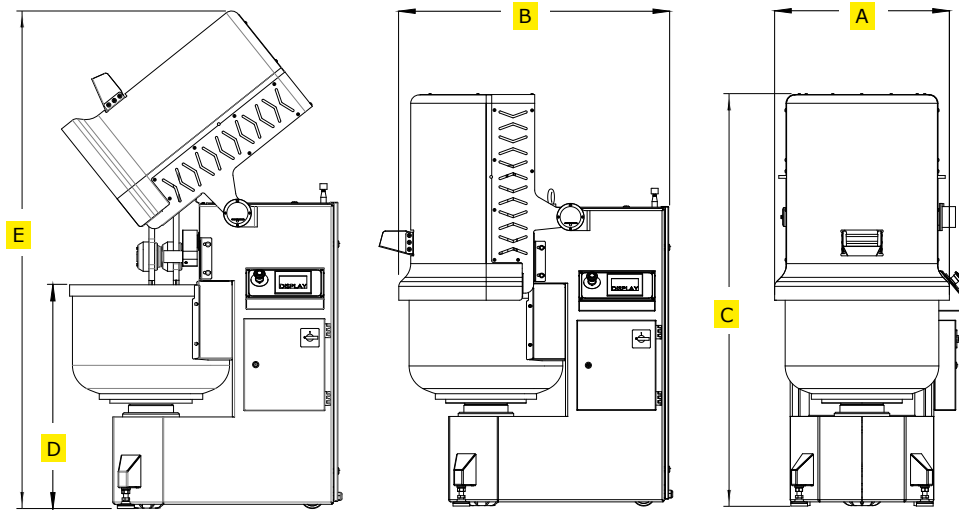

Model	Dimensions (mm)				
	A	B	C	D	E
Calypso 70	692	973	1424	682	1720
Calypso 80	692	973	1434	692	1726
Calypso 90	692	977	1484	742	1754

Packing		Model	Calypso 70	Calypso 80	Calypso 90
<b>Mainland (Cardboard box on palett)</b>	Width	(mm)	800	800	800
	Lenght	(mm)	1150	1150	1150
	Height	(mm)	1650	1650	1650
	Weight	(kg)	335	338	340
<b>By sea (wooden crate)</b>	Width	(mm)	860	860	860
	Lenght	(mm)	1210	1210	1210
	Height	(mm)	1670	1670	1670
	Weight	(kg)	380	382	385



## Bowl tilter

### Performances

#### **Bowl tilter compatible with:**

- Spiral mixers Spiral A
- Spiral mixers SPL A
- Fork type mixers FBL A

### The advantages

- Pouring of the dough onto a table or into a hopper
- Avoids long and restrictive manual handling
- Hydraulic lifting device for maximum safety
- Compatible with different Bongard removable bowls
- Outstanding reliability

### Use

The Bongard BDC bowl tilter has been designed to transfer the contents of a removable bowl mixer type Spiral SPL A or type FBL A kneader automatically onto a workbench or hopper of a volumetric divider.

### Operating principle

The two steel arms are placed under the bowl's trolley to guarantee completely safe hold. The hydraulic lifting and lowering system offers 2 speeds and is operated by independent pushbuttons.

### Construction

- Epoxy painted frame (food-grade)
- Sturdy steel structure
- Wheel-mounted & with floor securing system
- No floor anchoring necessary
- Dual manual safety controls
- Hydraulic lifting system for a minimum of maintenance (only on BDC 1, BDC 2, BDC 3 and BDC 4 models)
- 24 V control circuit (safety)
- Optional safety cage for BDC 1, BDC 2, BDC 3 and BDC 4
- Connecting power: 400 V 3 PH 50 Hz

### ■ Important notes:

When ordering, thank you for indicating the brand name, the type, the mixer's serial number and the hopper height for a proper adjustment of the BDC unloading height.

# BDC Bowl tilter

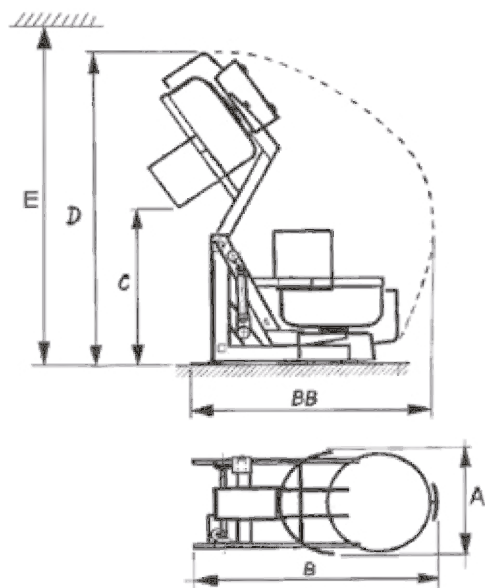

## Technical and general features

Model	Unloading height (mm)	Height under ceiling (mm)	For bowl (mm)	Spiral A	FBL A	Power (kW)	Net weight (kg)
BDC 1	1275	2800	Ø 900	250 / 300	230	1,13	340
BDC 2	1200	2850	Ø 1000	360 / 430	330	1,13	350
BDC 3	1800	3300	Ø 900	250 / 300	230	1,13	360
BDC 4	1700	3375	Ø 1000	360 / 430	330	1,13	370

## Dimensions (mm)

Model	Dimensions (mm)				
	A	B / BB	C	D	E
BDC 1	960	1700 / 2140	1275	2700	230:2750 / 300:2800
BDC 2	1100	1800 / 2200	1200	2750	330:2800 / 360:2850
BDC 3	960	1900 / 2250	1800	3200	230:3250 / 300:3300
BDC 4	1100	2000 / 2400	1700	3250	330:3300 / 360:3375

## Packing

Packing		Model	BDC 1	BDC 2	BDC 3	BDC 4
Mainland (Cardboard box on pallet)	width	(mm)	1100	1100	1100	1100
	length	(mm)	1700	1700	1700	1700
	Height	(mm)	1570	1570	1570	1570
	Weight	(kg)	360	360	360	360
By Sea (Wooden Crate)	width	(mm)	1200	1200	1200	1200
	length	(mm)	1800	1800	1800	1800
	Height	(mm)	1700	1700	1700	1700
	Weight	(kg)	440	440	440	440



## Vertical bowl hoist & tilter

### Performances

Bowl hoist & tilter compatible with:

- Spiral mixers Spiral A
- Spiral mixers SPL A
- Fork type mixers FBL A

### The advantages

- Pouring of the dough onto a table or into a hopper
- Avoids long and restrictive manual handling
- Hydraulic lifting device for maximum safety
- 3 fixed support points on the floor for better stability
- Compatible with different Bongard removable bowls
- Easy to set up
- Reduced floor space

### Use

The Bongard Tilti bowl hoist has been designed to transfer the contents of a removable bowl mixer type Spiral SPL A or type FBL A kneader automatically onto a workbench or hopper of a volumetric divider.

### Operating principle

The two steel arms are placed under the bowl's trolley to guarantee completely safe hold. The hydraulic lifting and lowering system offers 2 speeds and is operated by independent pushbuttons.

### 4 possible configurations

n°1 - **Tilti 1** :

The bowl is introduced by the front side for a discharge on the right.

n°2 - **Tilti 2** :

The bowl is introduced by the front side for a discharge on the left.

n°3 - **Tilti 3** :

The bowl is introduced on the left side for a discharge on the right.

n°4 - **Tilti 4** :

The bowl is introduced on the right side for a discharge on the left.

### Construction

- Epoxy painted frame (food-grade)
- Steel structure
- 3 support points fixed to the floor
- Peripheral protections
- Dual manual safety controls
- Bowl position detector
- Hydraulic lift system
- 24 V control circuit
- Connecting power : 400 V 3 PH 50 Hz

# Tilti Vertical bowl hoist

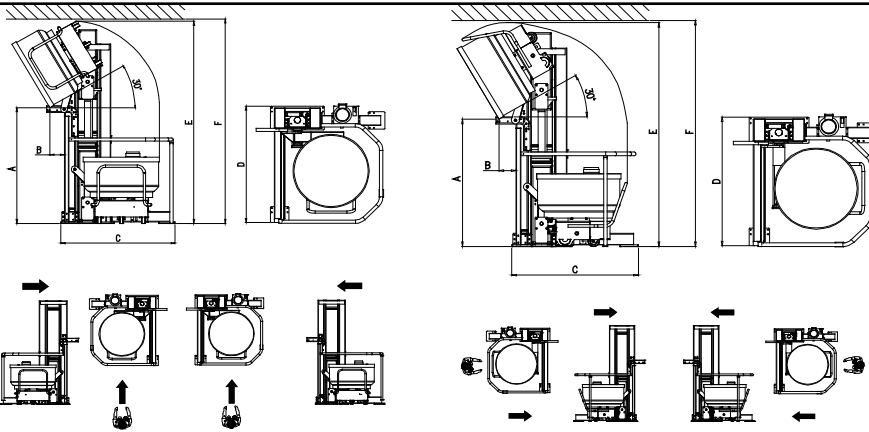

Tilti 1 and Tilti 2  
Bowl introduced by the front

Tilti 3 and Tilti 4  
Bowl introduced by the left side or the right side

Model
Tilti 1 unloading on the right side
Tilti 2 unloading on the left side
Tilti 3 unloading on the right side
Tilti 4 unloading on the left side

Models Tilti 1 - Tilti 2 (height under ceiling required 3000 mm)						
Bowl mode	Dimensions (mm)					
	A	B	C	D	E	F
Spiral A	1815	150	1615	1710	2965	3000
SPL A 250						
Spiral A	1785	200	1615	1710	2965	3000
SPL A 300						
FBL A 230						
Spiral A	1735	140	1615	1710	2965	3000
SPL A 360						
FBL A 330						

Models Tilti 3 - Tilti 4 (height under ceiling required 3100 mm)						
Bowl model	Dimensions (mm)					
	A	B	C	D	E	F
Spiral A	1915	150	1615	1710	3070	3100
SPL A 250						
Spiral A	1885	200	1615	1710	3070	3100
SPL A 300						
FBL A 230						
Spiral A	1835	140	1615	1710	3070	3100
SPL A 360						
FBL A 330						

General features						
Model			Tilti 1	Tilti 2	Tilti 3	Tilti 4
Bowl volume	Spiral A / FBL A	(l)	300 - 360	300 - 360	300 - 360	300 - 360
	FBL A	(l)	230 - 330	230 - 330	230 - 330	230 - 330
Power		(kW)	2,2	2,2	2,2	2,2
Net weight		(kg)	750	750	750	750

Packing						
Mainland (Cardboard box on pallet)	Model		Tilti 1	Tilti 2	Tilti 3	Tilti 4
	width	(mm)	2600	2600	2600	2600
	length	(mm)	1600	1600	1600	1600
	Height	(mm)	1500	1500	1500	1500
	Weight	(kg)	820	820	820	820
By Sea (Wooden Crate)	Model		Tilti 1	Tilti 2	Tilti 3	Tilti 4
	width	(mm)	2900	2900	2900	2900
	length	(mm)	1750	1750	1750	1750
	Height	(mm)	1600	1600	1600	1600
	Weight	(kg)	900	900	900	900

# Saturne 3



## Planetary mixers

### Performances

- Bowl volume : 20 - 60 litres depending on the models and equipment

### The advantages

- Ideal for working with small quantities and delicate products.
- Multi-purpose
- Delivered with a bowl and 3 tools (whip, flat beater, spiral)
- May be fitted with a heater under the bowl (accessory)
- 3 speeds or speed variator, depending on the model
- A choice of 3 type of controls
- Possibility of adapting same size bowl or reduction fitting for smaller sized bowl

### Use

The Saturne 3 is a planetary mixer designed for pastry shops and bakeries as well as small laboratories and commercial kitchen kitchens (creams, yeast doughs, sauces, mayonnaises, etc.)

The Saturne 3 EV planetary mixer with speed variator is specifically designed for pastry shops and small laboratories. Fitted with a variable electronic speed motor ranging from 30 to 125 rpm, it can be used for all recipes with the highest precision.

### Operating principle

The bowl containing the ingredients is placed on the mixer's cradle. A lever is used to raise the bowl which is blocked. The rotating grid guarantees safety during operation. Thanks to the planetary movement of its tools, the Saturne 3 is ideal for working smooth doughs, whipping egg whites, making mousses, creams and light whipped creams to perfection.

### Construction

- Saturne 3 M or E : 3 pre-set speeds 30, 60, 125 rpm
- Saturne 3 EV with speed variation from 30 to 125 rpm (achieves a higher degree of precision for all recipes).
- Epoxy coated body (food grade) on legs (easy cleaning).
- M model : control panel with push buttons.
- E and EV models : ergonomic control panel via digital keys.
- E and EV models : manual and automatic functions.
- Timer
- LED controlled functions on Saturne E and EV models.
- Lever type bowl lift
- Stainless bowl
- Functional bowl locking system
- Removable rotating safety grid (without tools)
- Supplied with 3 tools (whip, flat beater, spiral)
- 12/24 V control circuit
- Connecting power: 400 V 3 PH 50 Hz



# Saturne 3 Planetary mixers

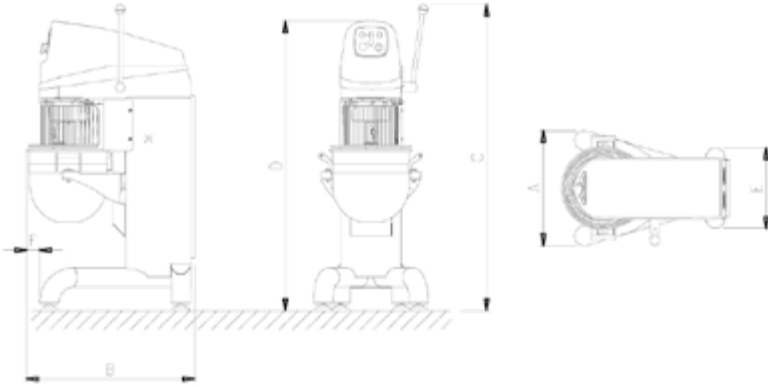

<b>General features</b>				
<b>Model</b>		<b>Saturne 3 - 20</b>	<b>Saturne 3 - 40</b>	<b>Saturne 3 - 60</b>
Bowl volume	(litre)	20	40	60
Possible reduction set : bowl + tools	(litre)	10–20	10–20–40	20 - 40–60
Power	(kW)	1,5 (M-E)	2,2	3,1
		2,2 (EV)		
<b>Dimensions and weight</b>				
W x D (A x B)	(mm)	601 x 855	601 x 855	681 x 981
Height with lever ( C)	(mm)	1510	1510	1620
Total height (D)	(mm)	1440	1440	1550
Net weight	(kg)	220	235	305

<b>Packing</b>				
<b>Mainland (Cardboard box on palett)</b>	<b>Model</b>	<b>Saturne 3 - 20</b>	<b>Saturne 3 - 40</b>	<b>Saturne 3 - 60</b>
	Width (mm)	(mm)	1080	1080
	Length (mm)	(mm)	850	850
	Height (mm)	(mm)	1750	1750
	Weight (kg)	(kg)	250	310
<b>By Sea (Wooden Crate)</b>	<b>Model</b>	<b>Saturne 3 - 20</b>	<b>Saturne 3 - 40</b>	<b>Saturne 3 - 60</b>
	Width (mm)	(mm)	1100	1100
	Length (mm)	(mm)	900	900
	Height (mm)	(mm)	1800	1800
	Weight (kg)	(kg)	290	350



# Saturne 3 Controls



Saturne 3 M-Electro-mechanical panel 3 pre-set speeds



Saturne 3 E-Electronic panel 3 pre-set speeds



Saturne 3 EV-Electronic panel variable speed

## Controls for planetary mixers

### Saturne 3 M - Electro-mechanical control with 3 pre-set speeds

#### Use

- Control panel with electro-mechanical components
- Timer controlling start and stop of the speed (from 0 to 30 minutes)
- Speed start push buttons
- Power ON lamp

### Saturne 3 E - Electronic controls with 3 pre-set speeds

#### Use

- Control panel with electronic components and digital keys
- Digital screen indicating the automatic decreasing and manual increasing of time
- Speed start keys
- Automatic or manual cycle key
- Cycle stop and/or reset key
- Time increase and decrease keys
- Power ON lamp
- 3 sensor status LED's

### Saturne 3 EV - Electronic controls with variable speed

#### Use

- Control panel with electronic components and digital keys
- Digital screen indicating the automatic decreasing and manual increasing of time
- Speed increase and decrease keys
- Automatic or manual cycle key
- Cycle stop and/or reset key
- Start up key
- Time increase and decrease keys
- Power ON lamp
- 3 sensor status LED's

### The advantages

- 3 vitesses : 30, 60, 125 t/min
- 3 commandes au choix
- Modèles disponibles avec ou sans variateur de vitesses

## Saturne 3 M - electromechanical control with 3 pre-set speeds

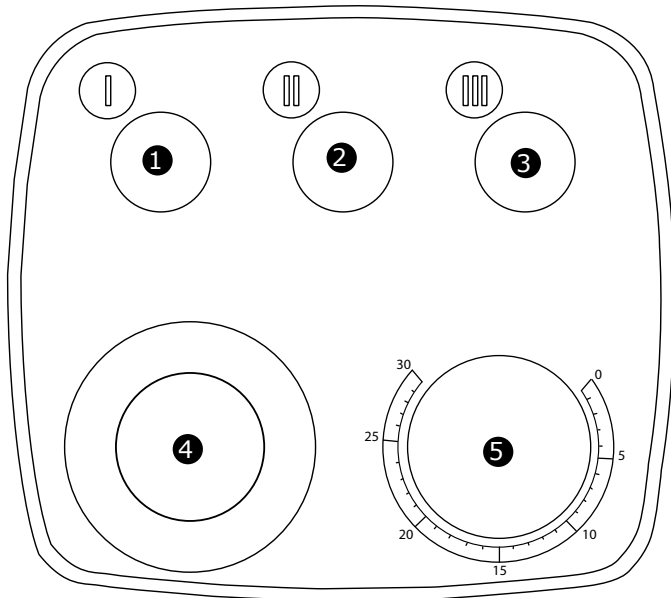

- 1 Cycle start - 1st speed
- 2 Cycle start - 2nd speed
- 3 Cycle start - 3rd speed
- 4 Emergency stop button
- 5 Timer

## Saturne 3 E - electronic controls with 3 pre-set speeds

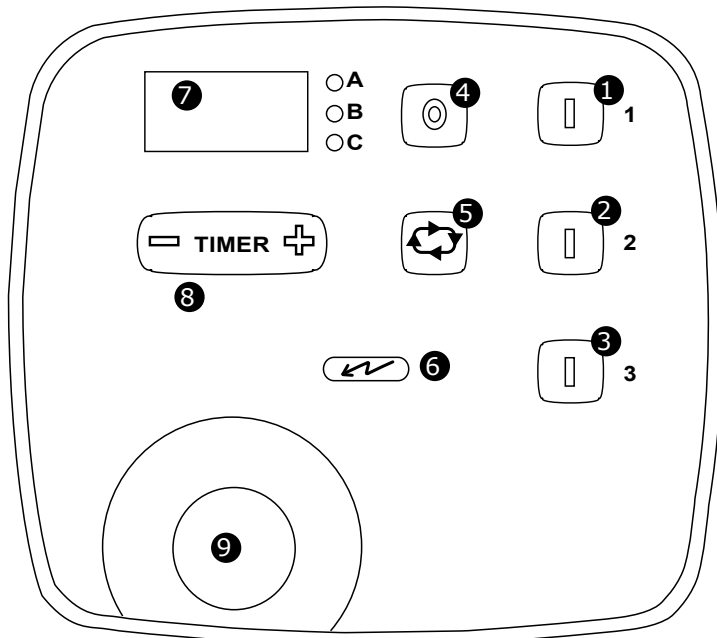

- 1 Cycle start - 1st speed
  - 2 Cycle start - 2nd speed
  - 3 Cycle start - 3rd speed
  - 4 Cycle stop
  - 5 Automatic or manual cycle
  - 6 Power on
  - 7 Digital display screen
  - 8 Time increasing (+) / decreasing (-) key
  - 9 Emergency stop button
- A = LED for closed grid / lid  
 B = LED for high position bowl  
 C = Planetary mixer in operation

## Saturne 3 EV - electronic controls with variable speed

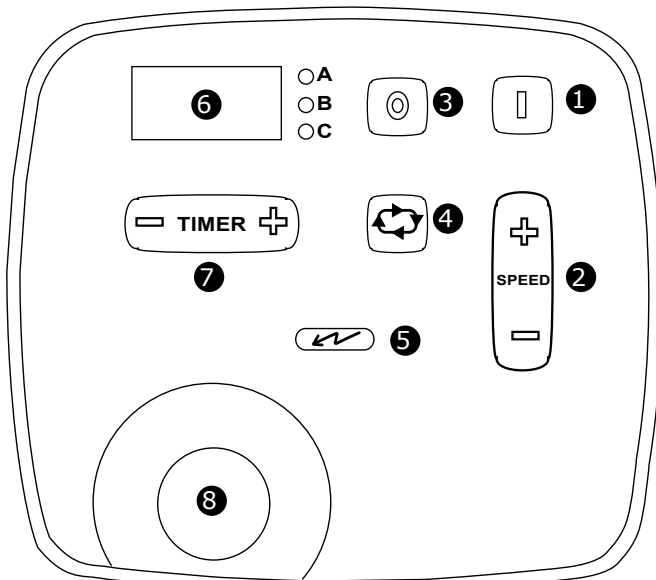

- 1 Cycle start
  - 2 Speed increasing (+) / decreasing (-) key
  - 3 Cycle stop
  - 4 Automatic or manual cycle
  - 5 Power on
  - 6 Digital display screen
  - 7 Time increasing (+) / decreasing (-) key
  - 8 Emergency stop button
- A = LED for closed grid / lid  
 B = LED for high position bowl  
 C = Planetary mixer in operation

# Stellar



## Tabletop planetary mixer

### Performances

- Volume of the bowl:  
20 litres

### The advantages

- Ideal for working with small quantities and delicate products
- Multi-purpose
- Comes with a bowl and 3 stainless steel tools (whisk, beater, spiral mixer) as standard.
- Can be equipped with a 12-litre bowl reducer kit (as an accessory)
- Available with a support designed for both use and the storage of its accessories
  
- Equipped with an electronic speed regulator from 30 to 125 rpm

### Use

Stellar is a compact mixer especially designed for small bakeries and pastry shops. It can be placed directly on a table or mounted on a support specifically designed for its use and the storage of its accessories.

### Operating principle

The bowl containing the ingredients is placed on the mixer's cradle. It is locked by two clamping levers located on each side of the bowl. The transparent PMMA cover guarantees safety during operation.

The Stellar planetary mixer is designed to be used on its support (as an accessory) or directly on the table (without wheels).

Stellar is ideal for preparing light mousses, creams and whipped cream, perfectly whipping egg whites and the occasional making of soft dough.

### Construction

- Stainless steel frame with a food contact compatible corrosion-resistant epoxy powder coating
- Mounted on 3 fixed legs and one height-adjustable leg
- Transparent cover made of scratch-resistant thermoformed PMMA
- Locking cylinder system to retain the hood
- Stainless steel bowl equipped with 2 side handles
- Functional bowl locking system with 2 locking levers
- Detachable chute
- Delivered with 3 tools (whisk, beater, spiral mixer)
- Mains voltage: single-phase 230 V 50 Hz

### Standard model

- Equipped with a high-resistance membrane keyboard
- Electronic control with speed regulator
- Manual and automatic operation
- Function control by indicator lights

### Optional

- Storage support mounted on 4 casters, with 2 stabilising legs
- All-stainless steel, 12-litre bowl reduction kit, delivered with a bowl and 3 tools

# Stellar Planetary mixer

Stellar	
Control type	
Electronical controls + speed variator	•
Bowl cover type	
Transparent safty cover	•
Locking mechanism to retain the cover	
Tools (all in stainless steel)	
Bowl	•
Whip	•
Flat beater	•
Spiral	•
Power supply	
230/1/50Hz	•
Accessories	
Reduction set 12l : bowl + 3 tools (whip, flat beater and spiral)	€
Stand with storage	€

Packing	Stellar						Stellar + stand
	Width	(mm)	1080	1080	1120	730	
Mainland (Cardboard box on palett)	Length	(mm)	850	850	850	700	760
	Height	(mm)	1750	1750	1900	990	1730
	Weight	(kg)	250	310	380	110	235
By Sea (Wooden Crate)	Width	(mm)	1100	1100	1200	750	730
	Length	(mm)	900	900	1000	720	780
	Height	(mm)	1800	1800	2000	1050	1790
	Weight	(kg)	290	350	420	140	250

# Stellar Planetary mixer

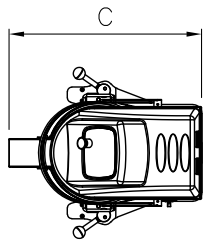
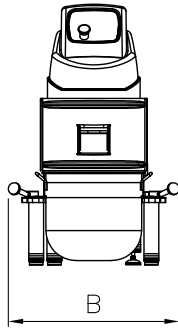
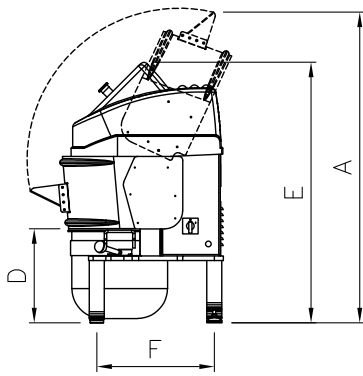

<b>General features</b>		
Bowl volume	(litre)	20
Possible reduction set : bowl + tools	(litre)	12
Power	(kW)	1,1
<b>Stellar</b>		
<b>Dimensions and weight</b>		
Height with opened lid (A)	(mm)	1037
Total width (B)	(mm)	572
Total depth with the chute (C)	(mm)	643
Bowl height (D)	(mm)	314
Height with closed lid (E)	(mm)	870
Distance between front and rear foot (F)	(mm)	393
Bowl diameter	(mm)	320
Height of the stand		-
Weight	(kg)	95

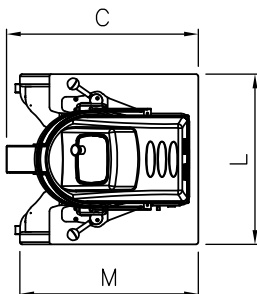
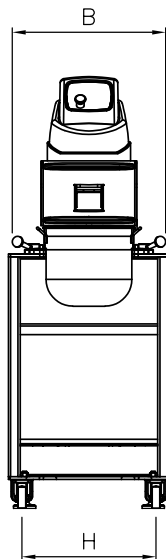
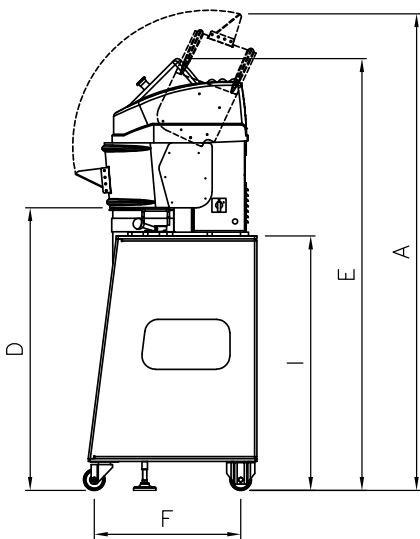

<b>Stellar + stand</b>		
<b>Dimensions and weight</b>		
Height with opened lid (A)	(mm)	1777
Total width of the stand (L)	(mm)	600
Total depth with the chute (C)	(mm)	676
Total depth without the chute (M)	(mm)	629
Height with closed lid (E)	(mm)	1610
Distance between front and rear foot (F)	(mm)	546
Height of the stand (I)	(mm)	949
Height of the stand + bowl (D)	(mm)	1054
Weight	(kg)	225





## Semi Automatic bun divider-rounder

### Performances

- From 14 to 52 divisions, depending on models
- Supplied with 3 synthetic dividing & moulding trays

### The advantages

- Dough pieces regular in size & weight
- Easy to clean
- Manual adjustment of the pressure depending on the type of dough
- Supplied with 3 synthetic dividing & moulding trays
- Compared to manual rounding:
  - Working ergonomics outstandingly improved
  - Significant labor time savings (at least 50%)
- Robust construction
- Equipment complying with European safety standards

### Use

The ERIS Semi Automatic bun-divider is designed to cut and shape the dough into round dough pieces in the same work cycle.

### Operating principle

Once weighted, the dough is placed on a division disk placed between the «head» of the machine and the platform. The «head» is then lowered and blades come down to cut the dough. Then, in a few movements, the oscillating platform forms the dough into perfectly identical round dough pieces. The number of divisions and weight of the dough pieces depend on the machine selected.

### Specificities of the " Semi Automatic " model:

- Dividing device by manual lever and motorized oscillating platform.
- Manual adjustment of eccentric movement with the operating handle.
- Setting with volume / weight bar depending on dough type.
- Rounding and pressing time is adjusted by the operator.
- Dividing disc can be cleared & tipped to the front for cleaning.

### Construction

- Cast iron base on castors
- Aluminium alloyed and Teflon coated dividing disc
- Aluminium alloyed oscillating platform
- Stainless steel knives
- Mechanical pressing and cutting movement
- Electromechanical rounding
- Quiet belt drive
- Removable pressing handle
- Voltage : 400 V 3 PH 50 HZ

# ERIS S.A. bun divider rounder

	ERIS SA 14-4	ERIS SA 30-3	ERIS SA 30-4	ERIS SA 36-4	ERIS SA 52-3
<b>Bowl</b>					
Round	■	■	■	■	■
<b>Divisions</b>					
14	■	❖	❖	❖	❖
30	❖	■	■	❖	❖
36	❖	❖	❖	■	❖
52	❖	❖	❖	❖	■
<b>Control Type</b>					
Semi-automatic	■	■	■	■	■

<b>Power supply</b>					
3N~ 400 V	■	■	■	■	■

<b>Accessories</b>					
Models	14-04	30-3	30-4	36-4	52-3
Round dough vat 380 mm. Depth 120 mm	€	€	€	€	€
Mobile rack for 8 vats. H 1880 x D 585 x W 575 mm	€	€	€	€	€
Plastic container on rack. Capacity : 170 liters	€	€	€	€	€
Interchangeable head (Sold with 3 trays)	❖	❖	❖	❖	❖

<b>Technical features (indicative values)</b>						
Models		ERIS SA 14-4	ERIS SA 30-3	ERIS SA 30-4	ERIS SA 36-4	ERIS SA 52-3
<b>Performance</b>						
Number of divisions		14	30	30	36	52
Dough piece weight	minimum (g)	86	30	40	33	17
	maximum (g)	261	86	122	101	50
Theoric cadence*	(p/h)	2800	6000	6000	7200	10400
Power	(kW)	0.55	0.55	0.55	0.55	0.55
<b>Dimensions and weight</b>						
Loading height	(g)	914	914	914	914	914
Overall	(mm)	625 x 625	625 x 625	625 x 625	625 x 625	625 x 625
Height	(mm)	1455	1455	1455	1455	1455
Arms raised Height	(mm)	2161	2161	2161	2161	2161
Net weight	(kg)	400	400	400	400	400

\* Depending upon operator efficiency and production flow

<b>Packing</b>							
<b>Mainland (Cardboard box on palett)</b>	Models		ERIS SA 14-4	ERIS SA 30-3	ERIS SA 30-4	ERIS SA 36-4	ERIS SA 52-3
	Width	(mm)	750	750	750	750	750
	Length	(mm)	900	900	900	900	900
	Height	(mm)	1700	1700	1700	1700	1700
	Weight	(kg)	420	420	420	420	420
<b>By Sea (Wooden Crate)</b>	Models		ERIS SA 14-4	ERIS SA 30-3	ERIS SA 30-4	ERIS SA 36-4	ERIS SA 52-3
	Width	(mm)	800	800	800	800	800
	Length	(mm)	950	950	950	950	950
	Height	(mm)	1750	1750	1750	1750	1750
	Weight	(kg)	420	420	420	420	420

# Eris A.



## Automatic bun divider-rounder

### Performances

- From 14 to 52 divisions, depending on models
- Supplied with 3 synthetic dividing & moulding trays

### The advantages

- Dough pieces regular in size & weight
- Easy to clean
- Manual adjustment of the pressure depending on the type of dough
- Supplied with 3 synthetic dividing & moulding trays
- Compared to manual rounding:
  - Working ergonomics outstandingly improved
  - Significant labor time savings (at least 50%)
- Robust construction
- Equipment complying with European safety standards

### Use

The ERIS Automatic bun-divider is designed to cut and shape the dough into round dough pieces in the same work cycle.

### Operating principle

Once weighted, the dough is placed on a division disk placed between the «head» of the machine and the platform. The «head» is then lowered and blades come down to cut the dough. Then, in a few movements, the oscillating platform forms the dough into perfectly identical round dough pieces. The number of divisions and weight of the dough pieces depend on the machine selected.

### Specificities of the " Automatic " model:

- Division device by hydraulic jack and motorised rounding oscillating platform controlled by a lever.
- Manual adjustment of eccentric movement with the operating handle.
- Setting with volume/ weight bar depending on dough type.
- Rounding and pressing time is adjusted by the operator.
- Dividing disc can be cleared & tipped to the front for cleaning.
- The dividing head & dividing + moulding trays are interchangeable from one model to another, whilst keeping the same machine body.

### Construction

- Cast iron base on castors
- Aluminium alloyed and Teflon coated dividing disc
- Aluminium alloyed oscillating platform
- Stainless steel knives
- Mechanical pressing and cutting movement
- Electro-mechanical rounding
- Quiet belt drive
- Removable pressing handle
- Supply voltage : 400 V 3 PH 50 Hz

## ERIS A. bun divider rounder

	ERIS A 14-4	ERIS A 30-3	ERIS A 30-4	ERIS A 36-4	ERIS A 52-3
<b>Bowl</b>					
Round	■	■	■	■	■
<b>Divisions</b>					
14	■	❖	❖	❖	❖
30	❖	■	■	❖	❖
36	❖	❖	❖	■	❖
52	❖	❖	❖	❖	■
<b>Control Type</b>					
Automatic	■	■	■	■	■

<b>Power supply</b>					
3N~ 400 V	■	■	■	■	■

<b>Accessories</b>					
Models	14-04	30-3	30-4	36-4	52-3
Plastic dough vat 380 mm. Depth 120 mm	€	€	€	€	€
Mobile rack for 8 vats : H 1880 x D 585 x W 575 mm	€	€	€	€	€
Plastic container on rack. Capacity : 170 litres	€	€	€	€	€
Interchangeable head (Sold with 3 trays)	€	€	€	€	€

<b>Technical features (indicative values)</b>						
Models		ERIS A 14-4	ERIS A 30-3	ERIS A 30-4	ERIS A 36-4	ERIS A 52-3
<b>Performance</b>						
Number of divisions		14	30	30	36	52
Dough piece weight	minimum (g)	86	30	40	33	17
	maximum (g)	261	86	122	101	50
Theoric cadence*	(p/h)	2800	6000	6000	7200	10400
Power	(kW)	1,3	1,3	1,3	1,3	1,3
<b>Dimensions and weight</b>						
Loading height	(g)	1120	1120	1120	1120	1120
Overall	(mm)	625 x 625	625 x 625	625 x 625	625 x 625	625 x 625
Height	(mm)	1759	1759	1759	1759	1759
Net weight	(kg)	440	440	440	440	440

\* Depending upon operator efficiency and production flow

<b>Packing</b>							
<b>Mainland (Cardboard box on palett)</b>	Models		ERIS A 14-4	ERIS A 30-3	ERIS A 30-4	ERIS A 36-4	DB3 A 52-3
	Width	(mm)	750	750	750	750	750
	Length	(mm)	900	900	900	900	900
	Height	(mm)	1850	1850	1850	1850	1850
	Weight	(kg)	460	460	460	460	460
<b>By Sea (Wooden Crate)</b>	Models		ERIS A 14-4	ERIS A 30-3	ERIS A 30-4	ERIS A 36-4	DB3 A 52-3
	Width	(mm)	800	800	800	800	800
	Length	(mm)	950	950	950	950	950
	Height	(mm)	1850	1850	1850	1850	1850
	Weight	(kg)	460	460	460	460	460

# Eris F.A.



## Full Automatic bun divider rounder

### Performances

- From 14 to 52 divisions, depending on models
- Supplied with 3 synthetic dividing & moulding trays

### Use

The ERIS Full Auto bun-divider is designed to cut and shape the dough into round dough pieces in the same work cycle.

### Operating principle

Once weighted, the dough is placed on a division disk placed between the «head» of the machine and the platform. The «head» is then lowered and blades come down to cut the dough. Then, in a few movements, the oscillating platform forms the dough into perfectly identical round dough pieces. The number of divisions and weight of the dough pieces depend on the machine selected.

### Specificities of the " Full Auto " model:

- Hydraulic division device and motorised rounding oscillating platform.
- Setting with volume/ weight bar depending on dough type.
- Rounding and pressing time is adjusted by an electronic control.
- Start-up of automatic cycle by 2 buttons
- Dividing disc can be cleared & tipped to the front for cleaning.
- The dividing head & dividing + moulding trays are interchangeable from one model to another, whilst keeping the same machine body

### Construction

- It is possible to program 10 different products with the electronic control
- Cast iron base on castors
- Interchangeable aluminium alloyed and
- Teflon coated dividing discs
- Aluminium alloyed oscillating platform
- Stainless steel knives
- Hydraulic pressing and cutting movement
- Mechanical rounding
- Quiet belt drive
- Supply voltage : 400 V 3 PH 50 Hz

### The advantages

- Dough pieces regular in size & weight
- Easy to clean
- Manual adjustment of the pressure depending on the type of dough
- Supplied with 3 synthetic dividing & moulding trays
- Compared to manual rounding:
  - Working ergonomics outstandingly improved
  - Significant labor time savings (at least 50%)
- Robust construction
- Equipment complying with European safety standards
- Completely automated operations



## ERIS F.A. bun divider rounder

	ERIS FA 14-4	ERIS FA 30-3	ERIS FA 30-4	ERIS FA 36-4	ERIS FA 52-3
<b>Bowl</b>					
Round	■	■	■	■	■
<b>Divisions</b>					
14	■	❖	❖	❖	❖
30	❖	■	■	❖	❖
36	❖	❖	❖	■	❖
52	❖	❖	❖	❖	■
<b>Control Type</b>					
Full-automatic	■	■	■	■	■

<b>Power supply</b>					
3N~ 400 V	■	■	■	■	■

<b>Accessories</b>					
Models	14-04	30-3	30-4	36-4	52-3
Round dough vat 380 mm. Depth 120 mm	€	€	€	€	€
Mobile rack for 8 vats. H 1880 x D 585 x W 575 mm	€	€	€	€	€
Plastic container on rack. Capacity : 170 liters	€	€	€	€	€
Interchangeable head (sold with 3 trays)	€	€	€	€	€

### Technical features (indicative values)

<b>Models</b>		<b>ERIS FA 14-4</b>	<b>ERIS FA 30-3</b>	<b>ERIS FA 30-4</b>	<b>ERIS FA 36-4</b>	<b>ERIS FA 52-3</b>
<b>Performance</b>						
Number of divisions		14	30	30	36	52
Dough piece weight	minimum (g)	86	30	40	33	17
	maximum (g)	261	86	122	101	50
Theoric cadence*	(p/h)	2800	6000	6000	7200	10400
Power	(kW)	1,3	1,3	1,3	1,3	1,3
<b>Dimensions and weight</b>						
Loading height	(g)	1120	1120	1120	1120	1120
Overall	(mm)	625 x 625	625 x 625	625 x 625	625 x 625	625 x 625
Height	(mm)	1759	1759	1759	1759	1759
Net weight	(kg)	440	440	440	440	440

\* Depending upon operator efficiency and production flow

### Packing

<b>Mainland (Cardboard box on palett)</b>	<b>Models</b>		<b>ERIS FA 14-4</b>	<b>ERIS FA 30-3</b>	<b>ERIS FA 30-4</b>	<b>ERIS FA 36-4</b>	<b>ERIS FA 52-3</b>
	Width	(mm)	750	750	750	750	750
	Length	(mm)	900	900	900	900	900
	Height	(mm)	1850	1850	1850	1850	1850
	Weight	(kg)	460	460	460	460	460
<b>By Sea (Wooden Crate)</b>	<b>Models</b>		<b>ERIS FA 14-4</b>	<b>ERIS FA 30-3</b>	<b>ERIS FA 30-4</b>	<b>ERIS FA 36-4</b>	<b>ERIS FA 52-3</b>
	Width	(mm)	800	800	800	800	800
	Length	(mm)	950	950	950	950	950
	Height	(mm)	1850	1850	1850	1850	1850
	Weight	(kg)	460	460	460	460	460



## Hydraulic divider

### Characteristics

- 20 divisions
- Rectangular aluminium bowl
- Tank volume 27 litres
- Min capacity: 4 kg of dough
- Max capacity: 20 kg of dough
- Optional: pressure regulator

### The advantages

- Compact:
  - Footprint: 800x600 mm
- Lightweight and manoeuvrable:
  - 200kg
  - On casters
  - Grip handle
- Comfortable and ergonomic:
  - Ergonomic lever
  - Handle height accessible to all: 1.60m
  - Flour projection prevention system
  - Very quiet (63dBA)
  - Stop & Go technology
  - Automatic knife lift
- Safety audited by an independent body

### Use

Mira is one of the most compact 20-division hydraulic dividers on the market. It can divide into equal dough pieces a previously weighed dough which may contain ingredients. Lightweight and manoeuvrable, the Mira divider has been designed with a view to making the division operation easier and reducing the risk of MSDs.

### Operating principle

#### • Division with the divider knives

Once weighed, the dough is placed in the divider bowl. Once the lid is closed, the user operates the lever, allowing the tray composed of floats to rise, thus equalizing the dough. Double-milled knives at the bottom of the bowl then rise to divide the dough into dough pieces of equal weight.

Once the dough has been cut, the user operates the lever in the opposite direction and the tray rises to allow the dough pieces to be recovered.

#### • Division with the 10-baguette grid

The Mira hydraulic divider can optionally be equipped with a removable 10-division grid, which allows the dough to be divided into equal dough pieces in the shape of baguettes.

A plate is placed at the bottom of the bowl before the dough is added, to prevent the knives from rising.

After the equalisation operation, the user opens the lid and places the grid on the bowl. The grid is then locked using the two lateral cams.

By operating the lever, the tray rises, allowing the dough pieces to be cut through the grid.

#### • Division with 40-division grid, double cut

Once the dough has been divided into 20 pieces with the divider knives, the user lowers the tray with the lever.

He/she then opens the lid and places the grid on the bowl. The grid is then locked using the two lateral cams.

By operating the lever, the tray rises, allowing the dough pieces to be cut in two through the grid, from 20 to 40 dough pieces.

### Construction





- Double-milled knives for a perfect cut
- Control by an ergonomic lever
- Silent hydraulic unit
- "Stop & go" system, the hydraulic system cuts off when not in use
- A hermetic seal and a system of vents prevent flour projections into the air
- The lid is locked by a handle fitted with a spring, ensuring it is always in the correct position
- Mechanically welded coated steel frame
- 2 multi-directional front casters with brakes and 2 mono-directional rear casters
- Aluminium bowl and rim
- High-impact resistance ABS/PMMA lid
- One-piece floats made from food-grade white techno polymer
- Painted steel grip handle
- Flour recovery tray at the rear

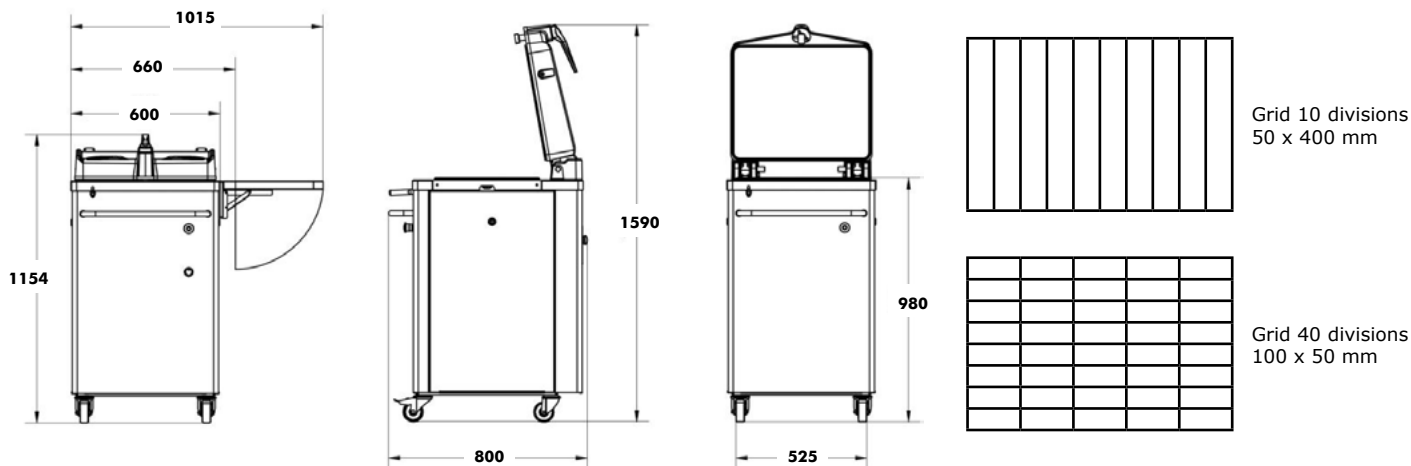

# Hydraulic divider **Mira**



<b>Mira</b>	
Divisions	
20	•
Control type	
Lever	•
Comfort	
Stop & Go function	•
4 castor (including 2 with brake)	•
Hygiene - security	
Automatic blade rise mechanism	•
Dust control system	•
Options	
Pressure regulator	€
Stainless steel fold-away extension table (left or right)	€
Removable grid	
grid 10 divisions + plastic board	€
grid 40 divisions (available with double cut only)	€
Power supply	
400V / TRI+N+T / 50-60Hz	•
208V-230V / TRI+T / 50-60Hz	o
3N~208-220V 60Hz US/C	€

<b>Accessories</b>	
	Rectangular dough vat
	Mobile rack for 8 vats (round or rectangular)
	Plastic container on rack
	

<b>General features</b>		
<b>Performances</b>		
Bowl depth	(mm)	129
Bowl dimensions	(mm)	500 x 400
Bowl volume	(l)	27
Minimum content of dough*	(kg)	4
Maximum content of dough*	(kg)	20
Hourly output	(p/h)	1200
Power	(kW)	1,5
Pressure	(bars)	53
Minimum pressure (with regulator)	(bars)	44
Maximum pressure (with regulator)	(bars)	53
<b>Dimensions and weight</b>		
Floor space	(mm)	800 x 600
Net weight	(kg)	200
Net weight with fold-away extension table	(kg)	15
Grid weight 10 divisions	(kg)	8
Grid weight 40 divisions	(kg)	7

<b>Packing</b>		<b>On pallet</b>	<b>Wooding crate</b>
<b>Mira</b>			
width	(mm)	900	900
Length	(mm)	1000	1000
Height	(mm)	1450	1500
Weight without pallet	(kg)	235	255
Weight with pallet	(kg)	250	270
<b>Removable grid</b>			
width	(mm)	600	600
Length	(mm)	760	760
Height	(mm)	210	210
Weight	(kg)	11	11

\* For a maximum resting time in tubs of 30 minutes

# Concorde 4



## Hydraulic divider with round bowl

### Performances

- 20 divisions
- Round dough compartment made of food grade alloy
- Bowl volume: 25 litres
- Dough capacity mini. : 3 kg
- Dough capacity maxi. : 18 kg

### The advantages

- Precise cutting
- Good distribution of the dough
- Equipped with a device against flour projection
- Comfort:
  - Ergonomic control panel
  - Very silent (<65db)
  - Stop & Go Technology
- Easy cleaning:
  - Automatic lifting of the cutters
  - 3 removable stainless steel (no tool necessary)
  - Smooth surfaces, stainless steel frame
  - Aluminium bowl
- Light, easy to move machine
- Perfect finishing
- The security of the machine has been audit by an independent organism

### Use

The Concorde 4 hydraulic divider is designed to divide a previously weighed dough chunk into equal dough pieces. It also gives the opportunity to divide a dough with a rate of moisture up to 70% or with some ingredients. The shape of the bowl has been specially designed to guarantee even distribution of the dough and a regular weight of the dough pieces.

### Operating principle

#### • Division with cutters :

Once weighted, the dough is placed in the divider bowl. Once the lid is closed, the user activates a button which lifts a tray consisting of pushers in order to equalise the dough. Then, double milling blades on the bottom of the bowl lift to divide the dough into equal weight pieces. Once the dough has been cut, the tray moves back up to allow easy grasp of the dough pieces.

#### • Rising of cutters for a careful cleaning

The divider comes with a blade rising system for easy cleaning: just lower the tray to the bottom of the bowl and keep pressing the « down » button so that the cutters of the divider come out.

### Construction

- Double milled knife for a perfect cut
- Control panel : two electromechanical buttons
- Silent hydraulic unit
- « stop & go » system: the hydraulic system automatically stops when it is not used.
- Bowl edge machined to incorporate vents to allow air to escape
- 3 removable stainless steel covers (side and rear)
- Lid and grid locked by drop-forged cam
- Mechanically welded frame coated in stainless steel
- 2 multi-directional castors with brakes and 2 mono-directional rear wheels for manoeuvrability
- Bowl and outer bowl rim in aluminium
- Cover in ABS , highly shock resistant
- Food grade single piece pusher
- Handgrip in stainless steel
- Trip switch with low power cut-out
- Flour dust catch tray for everyday use
- Supply voltage: 400 V 3 PH + N 50 HZ

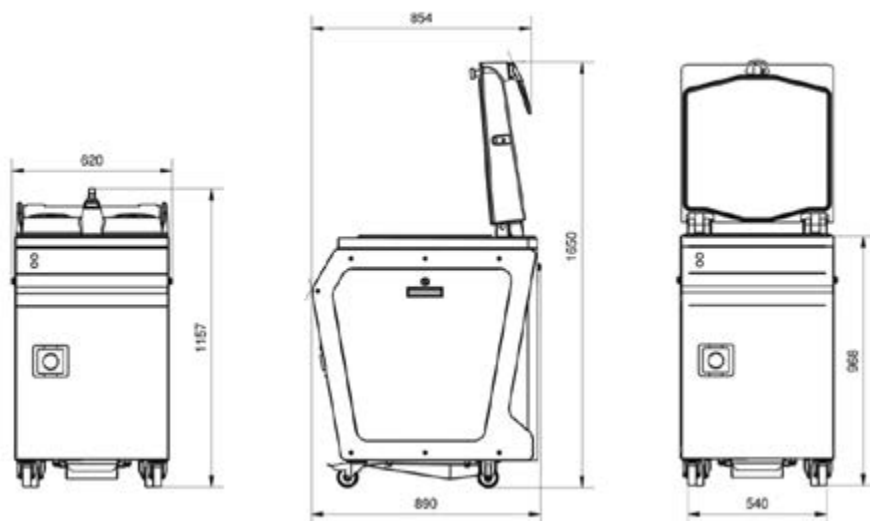

# Hydraulic divider **Concorde 4**



<b>Concorde 4</b>	
<b>Division</b>	
20 divisions	■
<b>Hygiene</b>	
Automatic blade rise mechanism	■
Dust control system	■
Stainless steel covers	■
Aluminium bowl and outer bowl rim	■
<b>Comfort</b>	
Silent hydraulic pump	■
Stop & Go function	■
Ergonomic control panel	■
<b>Supply voltage</b>	
TRI 400 V 50Hz	■

<b>General features</b>		
<b>Performances</b>		
Bowl depth	(mm)	129
Bowl dimensions	(mm)	500
Bowl volume	(l)	25
Minimum content *	(kg of dough)	3
maximum content *	(kg of dough)	18
Hourly output	(p/h)	1200
Power	(kW)	1,05
Pressure	(bars)	53
* For a maximum resting time in tubs of 30 minutes		
<b>Dimensions and weight</b>		
Floor space	(mm)	890 x 598

<b>Packing</b>		<b>On pallet</b>	<b>wooding crate</b>
<b>Width (mm)</b>	(mm)	760	800
<b>Length (mm)</b>	(mm)	980	1020
<b>Height (mm)</b>	(mm)	1260	1600
<b>Net weight (kg)</b>	(kg)	270	285

<b>Accessories</b>	
	round dough vat
	Mobile rack for 8 vats (round or rectangular)
	Plastic container on rack
	

# Mercure 4



## Hydraulic divider with rectangular bowl

### Performances

- Mercure 4 : 20 divisions
- Aluminium rectangular bowl
- Bowl volume: 27 litres
- Dough capacity mini. : 3 kg
- Dough capacity maxi. : 18 kg

### The advantages

- Precise cutting
- Large choice of grids
- Equipped with a device against flour projection
- Comfort:
  - Ergonomic control panel
  - Very silent (<65db)
  - Stop & Go Technology
- Easy cleaning:
  - Automatic lifting of the cutters
  - 3 removable stainless steel (no tool necessary)
  - Smooth surfaces, stainless steel frame
  - Aluminium bowl
- Light, easy to move machine
- Modular machine that can be fitted with a grid and grid frame afterwards
- Perfect finishing
- The security of the machine has been audited by an independent organism

### Use

The Mercure 4 hydraulic divider is designed to divide a previously weighed dough chunk into equal dough pieces. It also gives the opportunity to divide a dough with a rate of moisture up to 70% or with some ingredients. The shape of the bowl has been specially designed to guarantee even distribution of the dough and a regular weight of the dough pieces.

### Operating principle

#### • Division with cutters :

Once weighted, the dough is placed in the divider bowl. Once the lid is closed, the user activates a button which lifts a tray consisting of pushers in order to equalise the dough. Then, double milling blades on the bottom of the bowl lift to divide the dough into equal weight pieces. Once the dough has been cut, the tray moves back up to allow easy grasp of the dough pieces.

#### • Division with the grid:

In option, the hydraulic divider Mercure 4 may be equipped with a grid frame and a grid (8 grids available). Before using, the plastic board has to be placed above the pushers in order to avoid the cutters lifting. Once the dough is smoothed, the lid can be opened and the grid frame locked on the bowl. As the plastic board is lifting, the dough goes through the grid which acts like cutter. The dough pieces are formed.

#### • Rising of cutters for a careful cleaning:

The divider comes with a blade rising system for easy cleaning: just lower the tray to the bottom of the bowl and keep pressing the « down » button so that the cutters of the divider come out.

### Construction

- Double milled knife for a perfect cut
- Control panel : two electromechanical buttons
- Silent hydraulic unit
- « stop & go » system: the hydraulic system automatically stops when it is not used.
- Bowl edge machined to incorporate vents to allow air to escape
- Aluminium grid frame and 3mm stainless steel grids (optional)
- 3 removable stainless steel covers (side and rear)
- Lid and grid locked by drop-forged cam
- Mechanically welded frame coated in stainless steel
- 2 multi-directional castors with brakes and 2 mono-directional rear wheels for manoeuvrability
- Bowl and outer bowl rim in aluminium
- Cover in ABS , highly shock resistant
- Food grade single piece pusher
- Handgrip in stainless steel
- Trip switch with low power cut-out
- Flour dust catch tray for everyday use
- Supply voltage: 400 V 3 PH + N 50 HZ

# Hydraulic divider **Mercure 4**

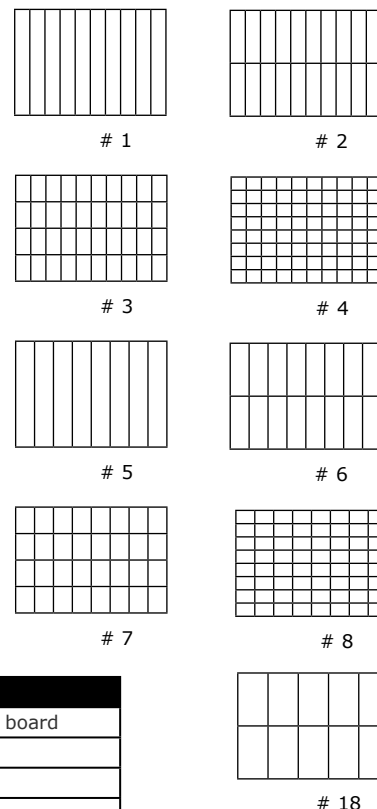
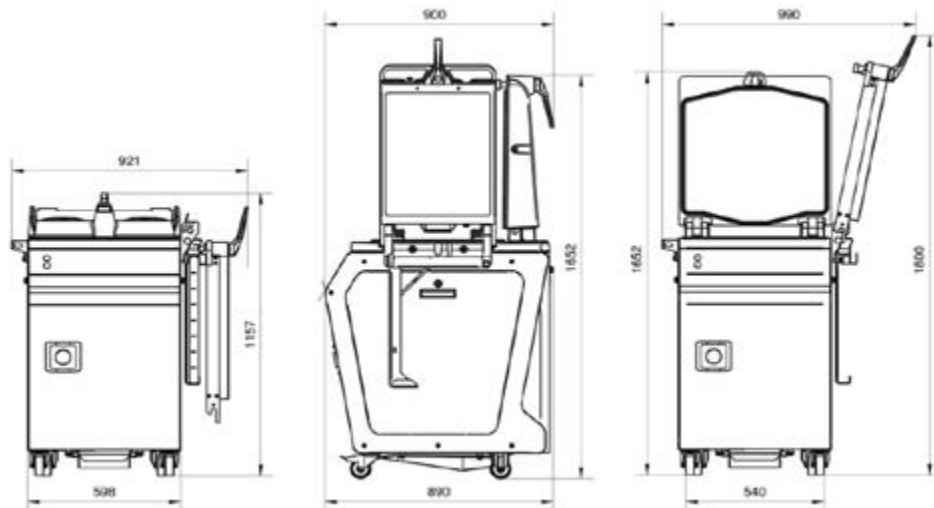

<b>Mercure 4</b>	
Division	
20 divisions	■
Grid frame + 1 choice of grid (*)+ plastic board	€
Grid holder	€
<b>Hygiene</b>	
Automatic blade rise mechanism	■
Dust contol system	■
Aluminium bowl and outer bowl rim	■
<b>Comfort</b>	
Silent hydraulic pump	■
Stop & Go function	■
Ergonomic control panel	■
<b>Supply voltage</b>	
TRI 400 V 50Hz	■
* Among the rid list	

<b>Grid</b>	
Kit: grid frame + 1 grid *+ plastic board	
Grid #1 - 10 divisions (400 X 50)	
Grid #2 - 20 divisions ( 200 X 50)	
Grid #3 - 40 divisions ( 100 X 50)	
Grid #4 - 80 divisions (50 X 50)	
Grid #5 - 8 divisions (400 X 60)	
Grid #6 - 16 divisions ( 200 X 60)	
Grid #7 - 32 divisions (100 X 60)	
Grid #8 - 64 divisions ( 50 X 60)	
Grid #18 - 10 divisions ( 200 X 100)	
Any other form of grid: contact us	

<b>General features</b>		
<b>Performances</b>		
Bowl depth	(mm)	129
Bowl dimensions	(mm)	512,5 x 409,5
Bowl volume	(l)	27
Minimum content *	(kg of dough)	3
Maximum content *	(kg of dough)	18
Hourly output	(p/h)	1200
Power	(kW)	1,05
Pressure	(bars)	53

<b>Dimensions and weight</b>		
floor space	(mm)	890 x 598
Net weight	(kg)	240
Net weight with grid frame + grid	(kg)	260

<b>Packing</b>		<b>On pallet</b>	<b>Wooding crate</b>
width	(mm)	760	800
Length	(mm)	980	1020
Height	(mm)	1260	1600
Height with frame and grid frame *	(mm)	1660	2000
Weight	(kg)	270	285
Weight with grid and grid frame *	(kg)	295	310

<b>Accessories</b>	
	Round dough vat
	Mobile rack for 8 vats (round or rectangular)
	Plastic container on rack

# Divimach



## Semi-automatic hydraulic divider

### Performances

- Dough pressing & dividing (10/20)
- Rectangular stainless steel bowl
- Bowl volume: 29,4 litres
- Dough capacity mini. : 4 kg
- Dough capacity maxi. : 20 kg

### The advantages

- No unnecessary pressure on the dough
- No risk of tearing the dough
- Favours better rounding and moulding as the dough pieces are all identical
- Silent
- Easy to clean thanks to its smooth surface and the automatic release of the blades
- Possibility of adapting a grid to cut the dough into buns, square or rectangular loaves, triangles on the AG and AGP.
- Electric locking of the blades to prevent the tray from rising
- Reduces flour dust thanks to a gasket between the top of the bowl and the anti-adherent plate of the lid

### Use

The Divimach hydraulic divider is designed to divide a previously weighed dough chunk into equal dough pieces. The AG and AGP are pre-fitted to receive a grid designed to make buns, ciabattas, triangles, etc.

### Operating principle

Once weighted, the dough is placed in the bowl. Once the lid is closed, the locking, dough pressing and division cycles are automatically run. Then, double milling blades on the bottom of the bowl lift to divide the dough into equal weight dough pieces. The machine is automatically unlocked at the end of the cycle.

A gasket and an ingenious air vent system reduce air and flour dust escaping. The shape of the dough pieces therefore offers better rounding and moulding quality. Once the dough has been cut, the tray moves back up to allow easy grasp of the dough pieces. Divimach starts automatically by activating the lid or a button on the control panel.

### Construction

- «Soft Dough» (medium pressure) function on AP and AGDP models
- Electric locking of the blades to prevent their release when the tray lifts up
- Dual effect jack to guarantee perfect return of the main tray and the blades
- Easy cleaning by rapid dismantling of the pushers
- Machine frame fitted on directional castors
- Power: 1.8 kW

### • • • Important notes:

The Divimach could be fitted with an optional selector to regulate pressure corresponding to hard dough and soft dough. This upgrade of the A model towards the AP and the AG model towards the AGDP can be done subsequently, without having to return the machine to the factory.

# Divimach semi-automatic hydraulic divider

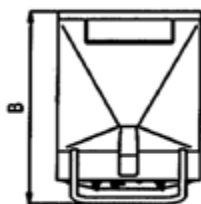
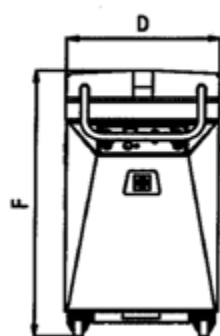
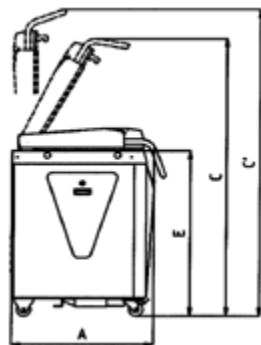

6 parts



40 divisions



6 parts



40 triangles

B = 100 mm x



8 parts



40 divisions



10 parts



80 divisions



16 parts

\* For fermented dough  
The baker can use a transfer plate to remove the dough Packing pieces

Models	
Models	
Divimach A standard	
Divimach AG with grid adaptation	
Divimach AP dual pressure	
Divimach AGDP with grid adaptation and dual pressure	

Grids	
Simple division with grid only*	
Grid 6 parts (166 x 200 mm)	
Grid 6 parts (513 x 65 mm)	
Grid 8 parts (513 x 50 mm)	
Grid 10 parts (50 X 400 mm)	
Grid 16 parts (62 x 200 mm)	
Double division with divider knives and grid	
Grid 40 divisions (100 X 50 mm)	
Grid 40 triangles (B = 100 mm x H = 100 mm)	
Grid 40 divisions (50 X 100 mm)	
Grid 80 divisions ( 50 X 50 mm)	

General features (indicative values)					
Model		Divimach A	Divimach AG	Divimach AP	Divimach AGDP
<b>Performances</b>					
Number of divisions		10/20	10/20	10/20	10/20
Bowl depth	(mm)	140	140	140	140
Bowl dimensions	(mm)	513 x 410	513 x 410	513 x 410	513 x 410
Weight of dough pieces (g) / Number of division	Mini.	400 / 10	400 / 10	400 / 10	400 / 10
		200 / 20	200 / 20	200 / 20	200 / 20
	Maxi.	2000 / 10	2000 / 10	2000 / 10	2000 / 10
		1000 / 20	1000 / 20	1000 / 20	1000 / 20
Non-stick pusher plate dimensions	(mm)	100 x 100	100 x 100	100 x 100	100 x 100
Dough capacity : mini.	(kg of dough)	4	4	4	4
Dough capacity : maxi.	(kg of dough)	20	20	20	20
Output	(p/h)	900 - 1250	900 - 1250	900 - 1250	900 - 1250
Power	(kW)	1,8	1,8	1,8	1,8
Loading height	(mm)	1000	1000	1000	1000
Overall D x B x F	(mm)	630 x 890 x 1140	630 x 890 x 1140	630 x 890 x 1140	630 x 890 x 1140
Height lid raised C'	(mm)	1860	1860	1860	1860
Footprint D x A	(mm)	630 x 820	630 x 820	630 x 820	630 x 820
Net weight	(kg)	380	380	380	380
Soft Dough (medium pressure)		No	No	Yes	Yes

Packing						
Mainland (Cardboard box on pallet)	Model		Divimach A	Divimach AG	Divimach AP	Divimach AGDP
	Width	(mm)	800	800	800	800
	Length	(mm)	950	950	950	950
	Height	(mm)	1350	1350	1350	1350
	Weight	(kg)	370	380	370	380
By Sea (Wooden Crate)	Model		Divimach A	Divimach AG	Divimach AP	Divimach AGDP
	Width	(mm)	850	850	850	850
	Length	(mm)	1000	1000	1000	1000
	Height	(mm)	1400	1400	1400	1400
	Weight	(kg)	390	400	390	400





## V-belt rounder

### Performances

- Output: 1800 pcs/h
- Dough piece weight: from 150 to 1200g

### The advantages

- Adapted to all types of standard weights
- Adapted to hybrid, sweet or firm dough consistencies
- Adapted to barely proofed or unproofed dough

### Use

BLP V-belt rounders are designed to shape the dough pieces just being divided into dough balls (pear shaped). They are placed between an automatic divider and an intermediate proofer. Rounding favours intermediate proofing as well as regular and even fermentation. It is recommended to use them with an automatic bread plant to ensure regular loading and presentation to the moulder. They are suitable for French-style recipes.

### Operating principle

On exiting a volumetric divider, the dough piece falls between the belts of the rounder spaced according to the required size of the dough piece. The 2 belts, which move in opposite directions, turn the dough around, forming a spherical shape.

### Construction

- 2 independent belts running in opposite directions
- Adjustment of the moulding V
- 2 drive motors
- Food-grade epoxy painted
- Electrically adapted for being integrated into a Delta or Medio intermediate proofer
- For stand alone installation, please consult us
- Supply voltage : 400 V 3 PH 50 HZ

# BLP V-belt rounder

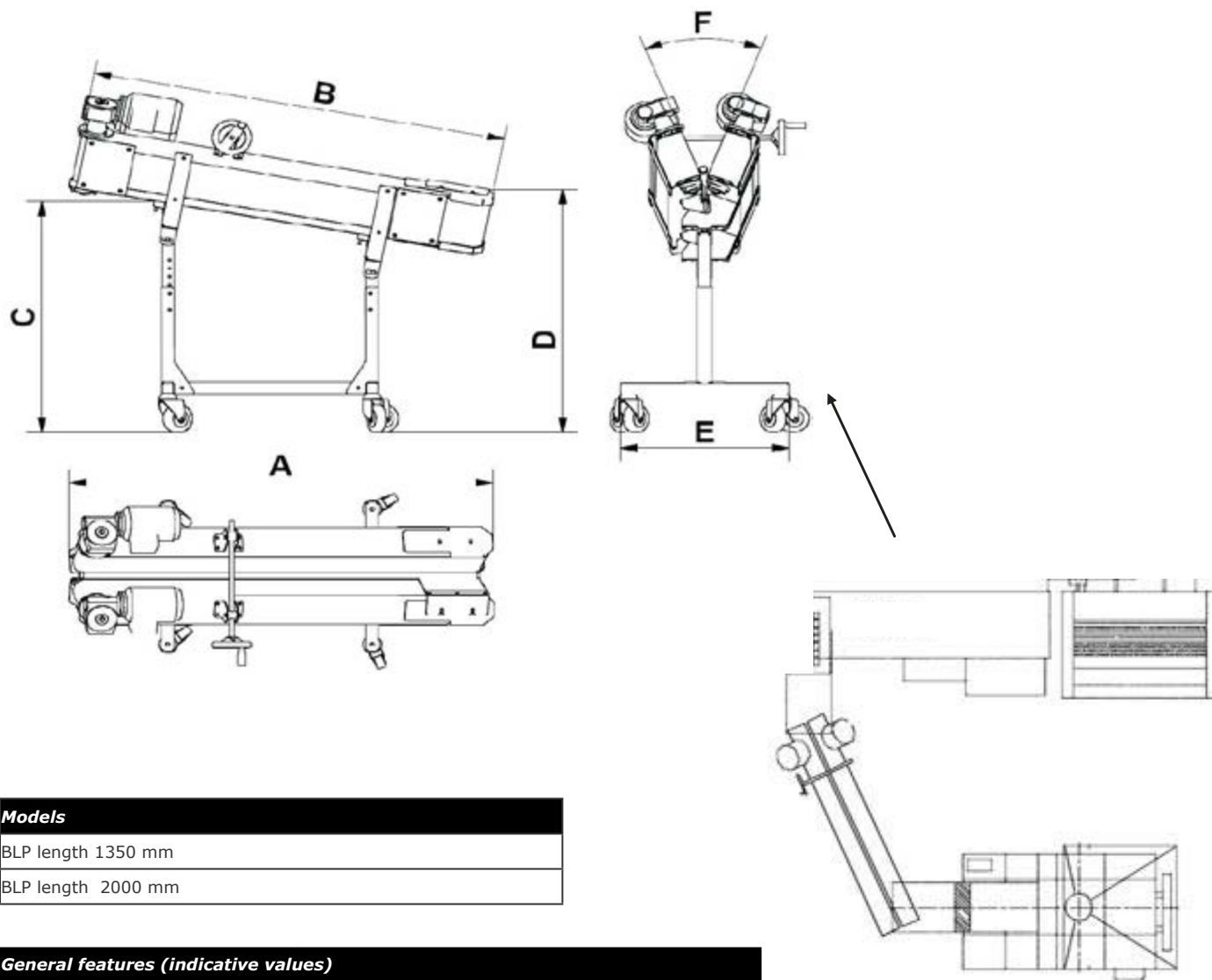

Models	
BLP length	1350 mm
BLP length	2000 mm

General features (indicative values)				
Model		BLP 1350	BLP 2000	
<b>Performances</b>				
Moulding length [B]	(mm)	1330	1980	
Maximum output	Maxi. (p/h)	2000	2000	
dough piece weight	Mini. (g)	150	150	
	Maxi. (g)	1200	1000	
Power	(kW)	0,4	0,4	
<b>Dimensions and weight</b>				
Overall	(mm)	1350 x 540	2000 x 540	
Loading height	Mini-maxi (mm)	880-970	800-890	
Discharge height	Mini-maxi (mm)	835-925	835-925	
Net weight	(kg)	90	110	

Packing				
Mainland (Cardboard box on palett)	Model		BLP 1350	BLP 2000
	Width	(mm)	1400	2050
	Length	(mm)	650	650
	Height	(mm)	800	800
	Weight	(kg)	90	110



## Conical rounder

### Performances

2 models

• Output:

BC4 : up to 2000 p/h

BC3 : up to 3000 p/h

• Dough piece weight : from 200 to 2300g, depending on models

### Use

BC rounders are designed to shape the dough pieces just being divided into round dough balls. They are placed between an automatic divider and an intermediate proofer. Rounding favours intermediate proofing as well as regular and even fermentation. It is recommended to use them with an automatic compressor to ensure regular loading and presentation to the moulder. The BC moulder is designed for firm dough and to obtain a tight crumb structure

### Operating principle

BC rounders consist of a frame on which a rotary cone is mounted surrounded by a cast iron gutter. Placed at the exit of a volumetric divider, the dough piece falls between the revolving cone and the gutter, then, drawn by the cone's movement, moves up the gutter to the top.

This action rounds the dough pieces.

### Construction

- Teflon coated cone
- Epoxy gloss (food-grade) frame
- Steel structure
- Mounted on wheels, with floor fixing rod
- Moulding by Teflon coated gutter
- Integrated flour duster
- 2 loading positions of dough pieces (marks 1 & 2 on drawings on next page)
- Optional: TB1 outfeed conveyor belt
- Supply voltage : 400 V 3 PH 50 HZ

### The advantages

- Adapted to all types of standard weights
- Adapted to firm dough consistencies
- Adapted to barely proofed or unproofed dough

# BC Conical rounder

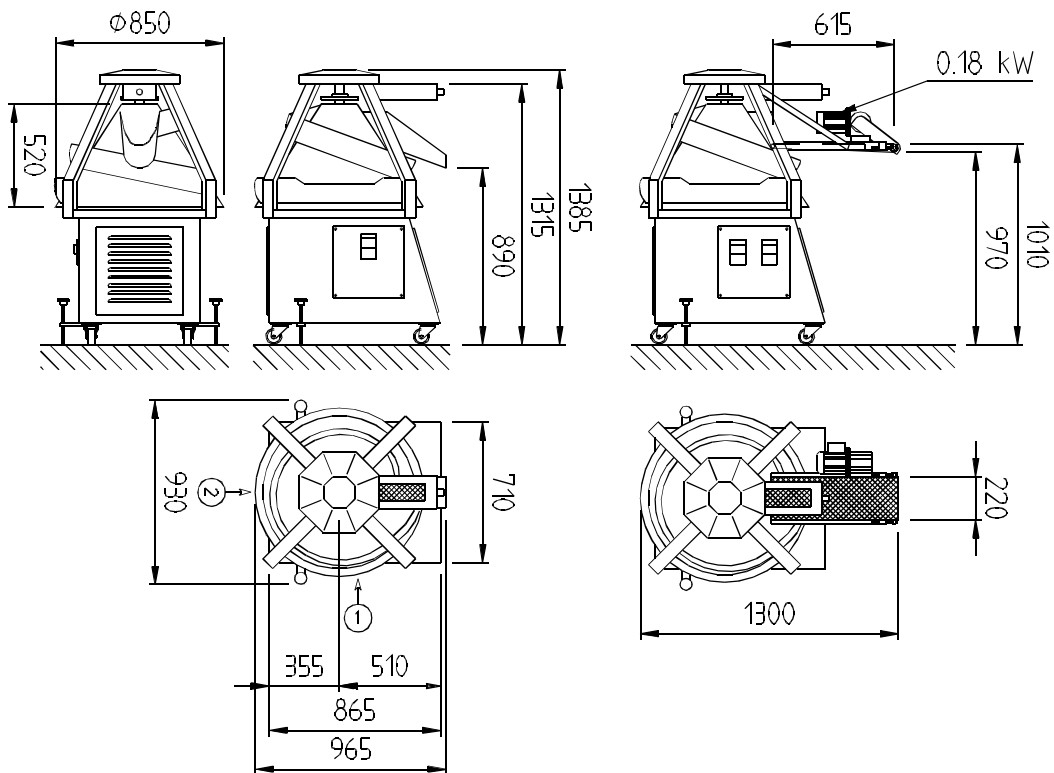

<b>Models</b>
BC 3
BC 4
<b>Options</b>
TB 1

<b>General features (indicative values)</b>				
<b>Models</b>		<b>BC 3</b>	<b>BC 4</b>	<b>Option TB1 pour BC</b>
<b>Performances</b>				
Output	Maxi. (p/h)	3000	2000	3000
dough piece weight	Mini-maxi (mm)	200-1200	400-2300	40-2300
Power	(kW)	0,75	1,1	0,18
<b>Dimensions and weight</b>				
Overall	(mm)	965 x 930	965 x 930	615 x 280
Height	(mm)	1385	1385	970
Net weight	(kg)	345	345	16

<b>Packing</b>				
	<b>Model</b>		<b>BC 3</b>	<b>BC 4</b>
<b>Mainland (Cardboard box on palett)</b>	Width	(mm)	1000	1000
	Lenght	(mm)	1000	1000
	Height	(mm)	1500	1500
	Weight	(kg)	385	385
<b>By Sea (Wooden Crate)</b>	<b>Model</b>		<b>BC 3</b>	<b>BC 4</b>
	Width	(mm)	1000	1000
	Lenght	(mm)	1000	1000
	Weight	(kg)	425	425



## Resting cabinet « chest » type

### Performances

- 5 models
- Number of carriers : 32 - 40, depending on models
- Number of dough pieces/pockets per carrier : from 6 to 9, depending on weight
- Manual use

### The advantages

- Compact
- High storage capacity
- Very easy to use
- Silent
- Adapted for use with any brand of moulder

### Use

The RP "chest" type resting cabinet is used for intermediate proofing. It is manually loaded and unloaded. While offering very high dough pieces storage capacity, the RP resting cabinet is very compact and is easily integrated into all small bakery configurations.

### Operating principle

Once weighed and divided, the dough pieces are placed in felt gutters. Then they rest between 15 and 30 minutes, depending on the strength of the dough and quality of the mixing. This intermediate proofing period favours gluten relaxation and thus produces dough that is easier to mould. Once the cycle is completed, the dough is unloaded manually onto the moulder.

### Construction

- Epoxy painted
- Composite sprockets with steel drive shafts
- Treated felt gutters, fixed by Velcro
- Quiet running
- Frame on directional castors
- Control with push buttons
- Closing lid mounted on hinges
- When in open position, the lid can be used as a foldaway rounding table.
- Rounding surface covered by felt
- Motor on top
- Control circuit : 230 V
- Socket for hydraulic divider
- Electrical connection for moulder
- Fits with the Major Manu moulders
- Running of the UV lamps and blower kit by timer during 2 hours
- Supply voltage : 400 V 3PH + N 50 HZ

### ••• Important notes :

The RP resting cabinets can be supply assembled, disassembled, with or without UV lamps and blower.

# RP Resting cabinet « chest » type

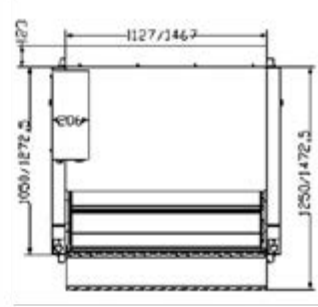
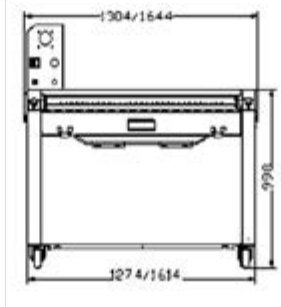

Options	
Model	Description
RP1 - RP3	UV lamp and blower kit
RP2 - RP4 - RP5	UV lamp and blower kit
Accessories	
Foot control	
For a nylon cup-shaped pocket, consult us	

General features (indicative values)						
Models		RP 1	RP 2	RP 3	RP 4	RP 5
Performances						
Dough piece weight	Maxi	630	630	630	630	1000
Number of pockets		32	32	40	40	32
« baguette » capacity	Useful pockets	7	9	7	9	9
	Baked baguette (250 g)	224	288	280	360	288
	Useful pockets	6	7	6	7	7
	Baked bread (400 g)	192	224	240	280	224
	Useful pockets	0	0	0	0	5
	Baked bread (750 g)	0	0	0	0	160
Power	(kW)	0,25	0,25	0,25	0,25	0,25
dimensions and weight						
Overall	(mm)	1320 x 1050	1660 x 1050	1320 x 1270	1660 x 1270	1660 x 1270
Loading height	(mm)	800	800	800	800	870
Height (motor +375 mm)	(mm)	998	998	998	998	998
Felt size (per carrier)	(mm)	1060 x 130	1400 x 130	1060 x 130	1400 x 130	1400 x 155
Net weight	(kg)	253	284	283	320	317

Packing for assembled resting cabinet							
Mainland (Cardboard box on pallet)	Model		RP 1	RP 2	RP 3	RP 4	RP 5
	Width	(mm)	1380	1730	1380	1730	1730
	Length	(mm)	1100	1100	1320	1320	1320
	Height	(mm)	1530	1530	1530	1530	1530
	Weight	(kg)	320	340	340	380	380
By Sea (Wooden Crate)	Model		RP 1	RP 2	RP 3	RP 4	RP 5
	Width	(mm)	1400	1750	1400	1750	1750
	Length	(mm)	1100	1100	1340	1340	1340
	Height	(mm)	1550	1550	1550	1550	1550
	Weight	(kg)	400	420	420	475	475

Packing for disassembled resting cabinet							
Mainland (Cardboard box on pallet)	Model		RP 1	RP 2	RP 3	RP 4	RP 5
	Width	(mm)	800	800	800	800	800
	Length	(mm)	1550	1550	1550	1550	1550
	Height	(mm)	1300	1700	1700	1800	1800
	Weight	(kg)	320	355	385	400	400

# Mada 2

## Manual intermediate proofer

### Performances

- 2 models: 1060 or 1240mm
- Number of carriers total: 51
- Number of carrier useful: 37
- Number of dough pieces/pockets: from 5 to 8, depending on models
- Dough piece weight: from 80 to 1000 g
- Manual mode

### The advantages

- High storage capacity
- Built-in 3 sides
- Full (integral) loading
- Loading carrier 2/2
- Very easy to use
- Silent
- Reduced floor area
- Colour system to visualize easily the loading phases

### Use

The manual intermediate proofer Mada2 is a machine intended for the intermediate proofing of dough before moulding.

### Operating principle

Once the control panel is in loading mode, the carriers move by 2 thanks to the 2 blue buttons located on both side of the machine. The loading of dough pieces is always manual. After resting, once the selector is on unloading mode, a single pressure on the push button makes the carriers turn around 1 by 1. The dough pieces are loaded on the conveyor belt, then conveyed to the moulder.

### Note :

It is possible to load the whole intermediate proofer. A colour code has been placed on 2 carriers (one blue and one red) in order to help the baker to visualize easily the loading.

### Construction

- Epoxy painted
- Cast iron sprockets with steel drive shafts
- Treated felt gutters, fixed by Velcro
- Gutter supplied on standard. Pockets of 650/1000g in option.
- Quiet running
- Frame on directional castors
- Control with push buttons for the loading mode (2 per 2)
- When in open position, the lid can be used as a foldaway rounding table.
- Rounding surface covered by felt
- Socket for hydraulic divider
- Electrical connection for moulder
- Fits with the Major Manu moulders
- Supply voltage : 400 V 3PH + N 50 HZ

### ••• Important note :

The Mada2 is not configured to be use with an automatic bread plant

## Mada 2 Manual intermediate proofer

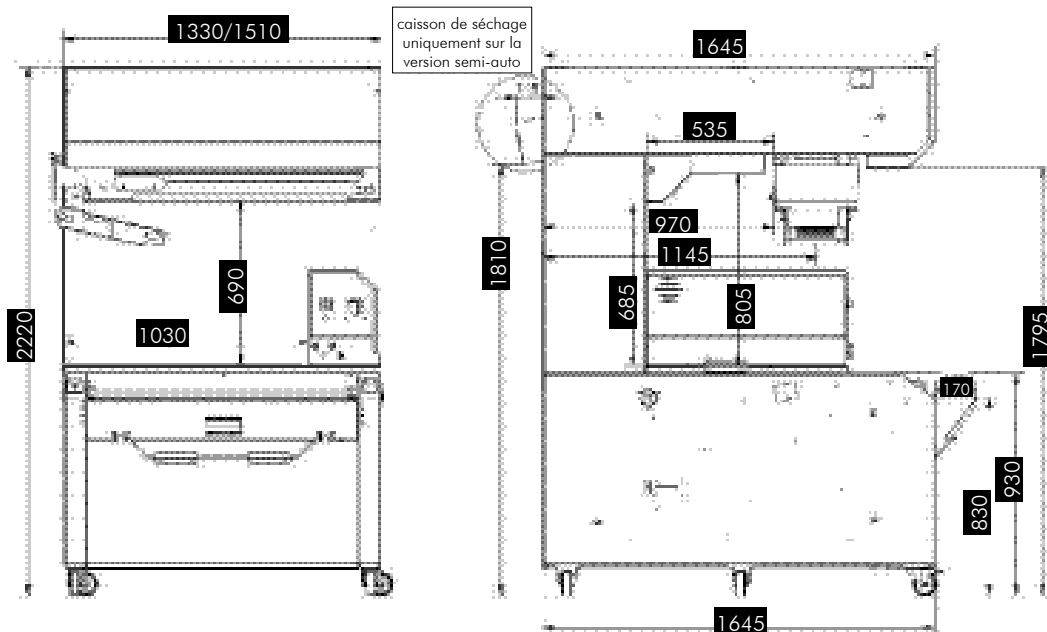

<b>General features (indicative values)</b>			
<b>Model</b>		<b>51-1000</b>	<b>51-1200</b>
Dough piece weight (mini-maxi)	(g)	80-1000	80-1000
<b>Full loading</b>			
Number of carrier		51	51
Total number of dough pieces (raw dough)	350g	7/357	8/408
	650g	6/306	7/357
	1000g	5/255	6/306
<b>Standard loading</b>			
Number of carrier		37	37
Total number of dough pieces (raw dough)	350g	7/259	8/296
	650g	6/222	7/259
	1000g	5/185	6/222
<b>Dimensions and weight</b>			
Carrier	(mm)	1060x130	1240x130
Overall (width x length)	(mm)	1330x1645	1510x1645
Loading height	(mm)	830	830
Height	(mm)	2220	2220
Net weight	(kg)	700	740
<b>Performances</b>			
Power	(kW)	0,4	0,4

### Packing for disassembled Mada 2

<b>Wooden crate (machine)</b>	<b>Model</b>		<b>51-1000</b>	<b>51-1200</b>
	Width	(mm)	1700	1700
	Length	(mm)	1000	1000
	Height	(mm)	2000	2000
	Weight	(kg)	580	620
<b>Wooden crate (carriers)</b>	<b>Model</b>		<b>51-1000</b>	<b>51-1200</b>
	Width	(mm)	1500	1500
	Length	(mm)	1200	1200
	Height	(mm)	1300	1300
	Weight	(kg)	200	200



# Mada 2 S.A.



## Semi-automatic intermediate proofer

### Performances

- 2 models: 1060 or 1240mm
- Number of carriers total: 51
- Number of carrier useful: 37
- Number of dough pieces/pockets: from 5 to 8, depending on models
- Dough piece weight: from 80 to 1000 g

### The advantages

- High storage capacity
- Built-in 3 sides
- Full (integral) loading
- Very easy to use
- Silent
- Reduced floor area
- Automatic research of the loading carrier and unloading carrier

### Use

The semi-automatic intermediate proofer Mada2 SA is a machine intended for the intermediate proofing of dough before moulding.

### Operating principle

Once the control panel is in loading mode, the carriers move by 2 thanks to the 2 blue buttons located on both side of the machine. The loading of dough pieces is always manual. After resting, once the selector is on unloading mode and the lid closed, the baker uses the timer to select the unload rating of the carriers. The dough pieces are deposited on the conveyor belt and conveyed to the moulder. The UV lamps and the blower guarantee a perfect hygiene.

### Note :

it is possible to load the whole intermediate proofer.

### Construction

- Epoxy painted
- Cast iron sprockets with steel drive shafts
- Treated felt gutters, fixed by Velcro
- Gutter supplied on standard. Pockets of 650/1000g in option.
- Quiet running
- Frame on directional castors
- Control with push buttons for the loading mode (2 per 2)
- When in open position, the lid can be used as a foldaway rounding table.
- Rounding surface covered by felt
- Socket for hydraulic divider
- Electrical connection for moulder
- Fits with the Major Manu moulders
- Supply voltage : 400 V 3PH + N 50 HZ

### ••• Important note :

The Mada2 is not configured to be use with an automatic bread plant

# Mada2 Manual intermediate proofer

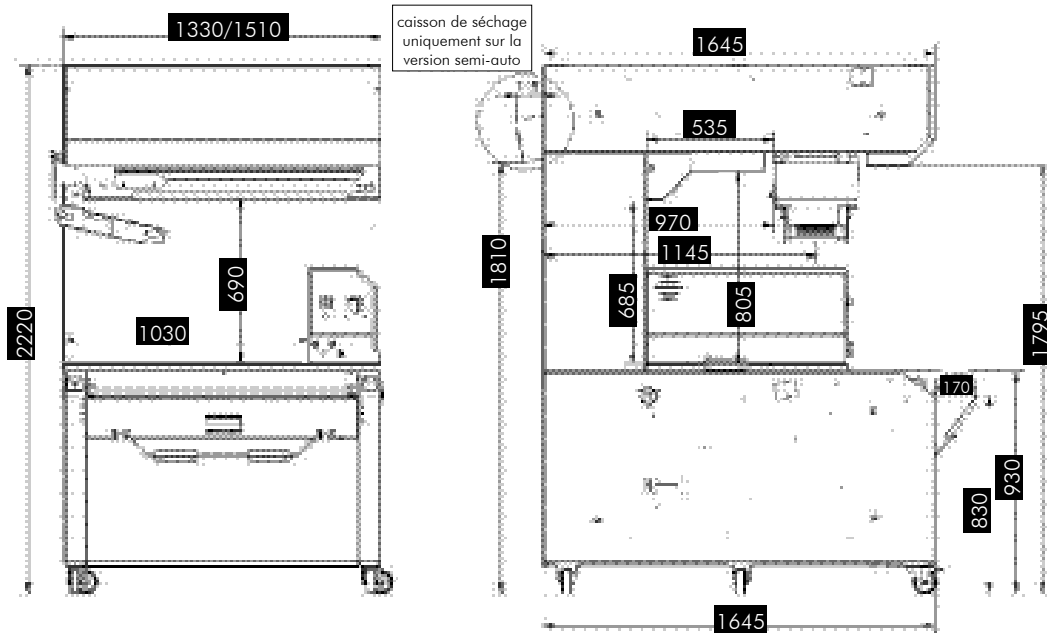

<b>General features (indicatives values)</b>			
<b>Model</b>		<b>51-1000</b>	<b>51-1200</b>
Dough piece weight (mini-maxi)	(g)	80-1000	80-1000
<b>Full loading</b>			
Number of carrier		51	51
Total number of dough pieces (raw dough)	350g	7/357	8/408
	650g	6/306	7/357
	1000g	5/255	6/306
<b>Standard loading</b>			
Number of carrier		37	37
Total number of dough pieces (raw dough)	350g	7/259	8/296
	650g	6/222	7/259
	1000g	5/185	6/222
<b>Dimensions and weight</b>			
Carrier	(mm)	1060x130	1240x130
Overall (width x length)	(mm)	1330x1645	1510x1645
Loading height	(mm)	830	830
Height	(mm)	2220	2220
Net weight	(kg)	700	740
<b>Performances</b>			
Power	(kW)	0,6	0,6

<b>Packing for disassembled Mada2</b>				
<b>Wooden crate (machine)</b>	<b>Model</b>		<b>51-1000</b>	<b>551-1200</b>
	Width	(mm)	1700	1700
	Length	(mm)	1000	1000
	Height	(mm)	2000	2000
	Weight	(kg)	580	620
<b>Wooden crate (carriers)</b>	<b>Model</b>		<b>51-1000</b>	<b>551-1200</b>
	Width	(mm)	1800	1800
	Length	(mm)	1500	1500
	Height	(mm)	1300	1300
	Weight	(kg)	200	200

# Medio S.A.



## Semi-automatic intermediate proofer

### Performances

Number of carriers : from 22 to 84, depending on model

- Number of pockets per carrier: 6 or 7 pockets of 650 g maximum
- 5 or 6 pockets of 1000 g maximum
- Dough piece weight: from 80 to 1000 g, depending on model

### The advantages

- High storage capacity
- Full loading
- Possibility of unloading the machine while continuing to load
- Very easy to use
- Silent
- Automatic dough resting cycle
- Adapted for use with any Bongard moulder
- Ideal to make special breads

### Use

The Medio SA semi-automatic intermediate proofer is a machine intended for the intermediate proofing of dough. It is suitable for bakers processing between 800-1200 dough pieces from 60 to 1000g per hour.

### Operating principle

Once weighed and divided, the dough pieces are placed in felt gutters. Then they rest between 15 and 30 minutes, depending on the strength of the dough and quality of the mixing. This intermediate proofing period favours gluten relaxation and thus produces dough that is easier to mould. Once weighed and divided, the dough pieces are placed in felt pockets. Useable in discontinuous mode (by one person) or continuous mode (by two people), the side loading is manual while frontal unloading is motorised towards the moulder.

It should be noted that the Medio SA intermediate proofer offers the possibility of integral loading to fill all the proofer's carriers. It also allows silent movement of the carriers without any risk of blocking. The carriers are composed of treated felt pockets on a thermoformed frame or gutters to avoid sticking and maintain a constant hygrometric level of the dough pieces.

### Construction

- Epoxy painted (food-grade)
- UV lamps
- Humidity extractors
- Cast iron sprockets with steel drive shafts
- Moulding table
- Quiet running
- Hanging control panel
- Electrical thermal overload protection of the Major moulder and the out-feed belt TE
- On castors
- Control circuit : 24 V
- Supply voltage : 3PH + N 400 V 50/60 Hz

### Options:

- Blower to dry felts
- Adjustable flour duster
- Transforming manual loading mode to automatic mode

### • • • Important note :

Nylon mesh pockets on request without extra cost

## Medio SA semi-automatic intermediate proofer

---

- • • How to understand the reference, ex : MEDIO SA10 650-6-52 ?

SA 10 : width of carriers : 1060 mm

650 : maximum dough weight per pocket (in g)

6 : Pockets per carrier

52 : Number of carriers

<b>Available models</b>
<b>Medio SA10 Model 650</b>
Intermediate proofer Medio SA10 650-6-62
Intermediate proofer Medio SA10 650-6-74
Intermediate proofer Medio SA10 650-6-84
<b>Medio SA10 Model 1000</b>
Intermediate proofer Medio SA10 1000-5-62
Intermediate proofer Medio SA10 1000-5-74
Intermediate proofer Medio SA10 1000-5-84
<b>Medio SA12 Model 650</b>
Intermediate proofer Medio SA12 650-7-62
Intermediate proofer Medio SA12 650-7-74
Intermediate proofer Medio SA12 650-7-84
<b>Medio SA12 Model 1000</b>
Intermediate proofer Medio SA12 1000-6-62
Intermediate proofer Medio SA12 1000-6-74
Intermediate proofer Medio SA12 1000-6-84

<b>Options</b>	<b>Model</b>
Felt dryer with blower at rear	MEDIO SA 10
Felt dryer with blower at rear	MEDIO SA 12
Felt dryer with blower on the roof	MEDIO SA 10
Felt dryer with blower on the roof	MEDIO SA 12
Flour duster for 650 g pockets	MEDIO SA 10
Flour duster for 650 g pockets	MEDIO SA 12
Flour duster for 1000 g pockets	Medio SA 10
Flour duster for 1000 g pockets	Medio SA 12

# Medio SA 10 semi-automatic intermediate proofer

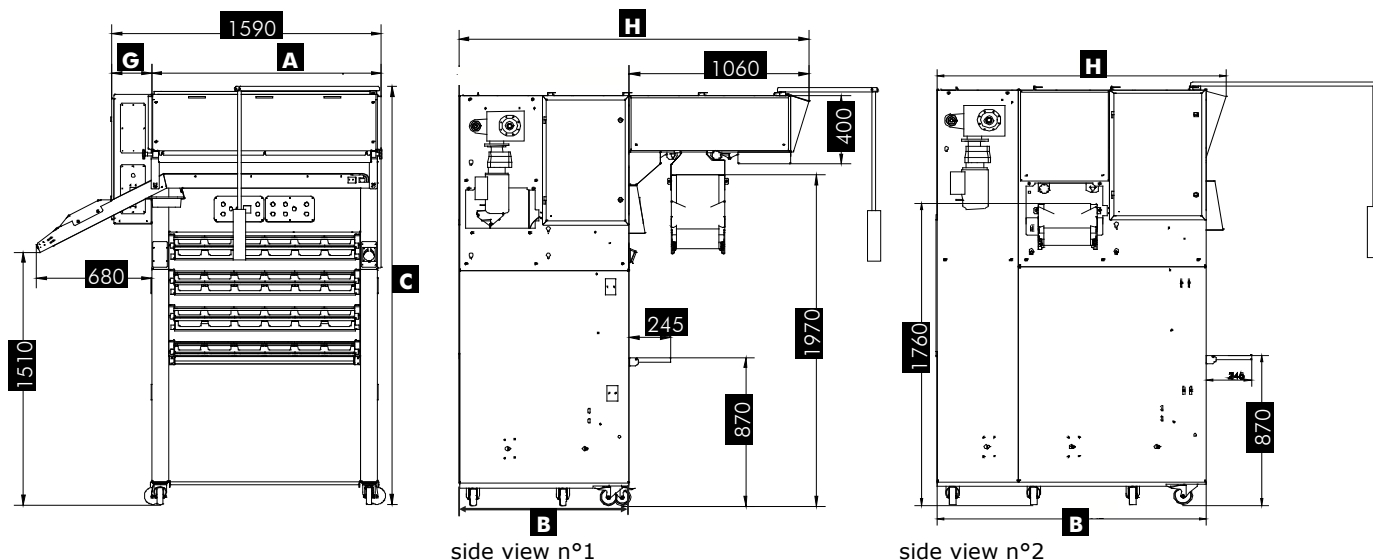

<b>General features</b>				
		<b>SA10</b>	<b>SA10</b>	<b>SA10</b>
		<b>650-6-62</b>	<b>650-6-74</b>	<b>650-6-84</b>
<b>Models SA 10</b>		<b>1000-5-62</b>	<b>1000-5-74</b>	<b>1000-5-84</b>
Width carriers	(mm)	1060	1060	1060
<b>Performances</b>				
Number of carriers		62	74	84
Number of pockets (total and useful) per integral loading	650	6/372	6/444	6/504
	1000	5/310	5/370	5/420
Dough weight mini.-maxi. (g)	650	80 - 650	81 - 650	82 - 650
	1000	80 - 1000	81 - 1000	82 - 1000
<b>Dimensions / Weight / Power</b>				
Side view		View 2	View 1	View 2
A (mm)	(mm)	1350	1350	1350
B (mm)	(mm)	1440	1440	1870
C (mm)	(mm)	2460	2460	2460
G (mm) control panel	(mm)	240	240	240
H (mm)	(mm)	1610	2500	2050
Net weight Medio only (kg)	(kg)	850	950	1000
Power Medio only (kW)	(kW)	0,55	0,55	0,55
Electrical power - including all options - with divider, moulder and TE (kW)	(kW)	2,7	2,7	2,7

<b>Packing for Models SA 10</b>					
	<b>Model SA 10</b>		<b>650-6-62</b>	<b>650-6-74</b>	<b>650-6-84</b>
			<b>1000-5-62</b>	<b>1000-5-74</b>	<b>1000-5-84</b>
<b>Mainland or By sea : (Wooden Crate)</b>	Width	(mm)	1200	1200	1200
	Length	(mm)	2650	2650	2650
	Height	(mm)	1800	1800	1800
	Weight	(kg)	1075	1225	1275

# Medio SA 12 Semi-automatic intermediate proofer

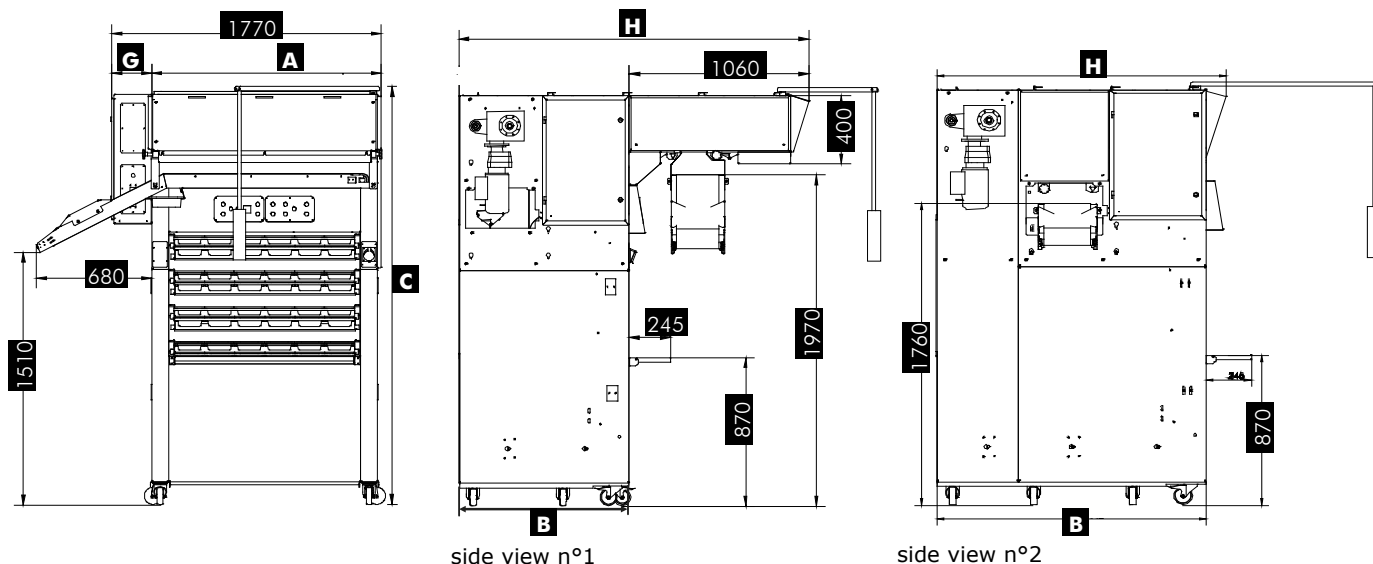

Models SA 12		SA12	SA12	SA12
		650-7-62 1000-6-62	650-7-74 1000-6-74	650-7-84 1000-6-84
Width carriers		1240	1240	1240
<b>Performances</b>				
Number of carriers		62	74	84
Number of pockets (total and useful) per integral loading 650 g	Mini-Maxi	7/434	7/518	7/588
1000 g	Mini-Maxi	6/372	6/444	6/504
Dough weight mini.-maxi. 650 g	Mini-Maxi	80 - 650	80 - 650	80 - 650
1000 g	Mini-Maxi	80 - 1000	80 - 1000	80 - 1000
<b>Dimensions / weight / power</b>				
Side view		view 2	View 1	View 2
A	(mm)	1530	1530	1530
B	(mm)	1440	1440	1870
C	(mm)	2460	2460	2460
G - control panel	(mm)	240	240	240
H	(mm)	1610	2500	2050
Net weight Medio only	(kg)	850	950	1000
Power Medio only	(kW)	0,55	0,55	0,55
Electrical power - including all options -with divider, moulder and TE	(kW)	2,7	2,7	2,7

<b>Packing for Models SA 12</b>					
	Model SA 12		650-7-62	650-7-74	650-7-84
			1000-6-62	1000-6-74	1000-6-84
<b>Mainland or By sea : (Wooden Crate)</b>	Width	(mm)	1200	1200	1200
	Length	(mm)	2650	2650	2650
	Height	(mm)	1800	1800	1800
	Weight	(kg)	1075	1225	1275

# Medio F.A. Auto



For more information about the group mode, see pages « Groupe Auto »

## Automatic intermediate proofer with loading station

### Performances

- Number of carriers: 70
- Number of pockets per carrier: 6 or 7
- Medio FA Auto is equipped, depending on models, with :
  - pockets for 650 g dough capacity maximum
  - Or :pockets for 1000 g dough capacity maximum

### The advantages

- High storage capacity
- Full loading
- Possibility of unloading the machine while continuing to load
- Very easy to use
- Silent
- Adapted for use with any Bongard moulder

### Use

The automatic Medio FA Auto intermediate proofer with loading station is a machine designed for intermediate proofing of dough pieces aimed at bakers making up to 1,200 dough pieces per hour, from 100 to 1000 g depending on the model chosen.

### Operating principle

Once weighed and divided, the dough pieces are placed in felt gutters. Then they rest between 15 and 30 minutes, depending on the strength of the dough and quality of the mixing. This intermediate proofing period favours gluten relaxation and thus produces dough that is easier to mould. Once weighed and divided, the dough pieces are placed in felt pockets. Useable in discontinuous mode (by one person) or continuous mode (by two people), the side loading is manual while frontal unloading is motorised towards the moulder.

Integrated in the bread plant, one single operator is able to operate the Medio FA Auto into discontinuous and continuous mode, thanks to automatic loading and motorised unloading towards the moulder. The Medio FA Auto is fitted with a pallet type loading station, which load and distribute dough pieces in carriers with pockets. The loading station comes in standard with a T3 (600 mm long) or T4 (800 mm long) infeed conveyor belt and a flour duster.

Placed at the exit, the transfer conveyor belt is used to feed the moulder automatically. The Medio FA Auto is fitted with treated pockets avoiding sticking and maintaining a constant hygrometric level of the dough pieces (nylon mesh pockets are available on demand at no extra cost).

Major Auto moulders are recommended with the Medio FA Auto.

### Construction

- Epoxy painted (food-grade)
- Dough piece transfer belt to the right or the left (to be specified)
- Humidity extractors
- Hanging control panel
- Cast iron sprockets with steel drive shafts
- UV lamps, felt drying blower on the roof or on the rear of the proofer (to be specified at order)
- Quiet running
- Electrical thermal overload protection of the Major moulder and the out-feed belt TE
- On castors
- Control circuit : 24 V
- Supply voltage : 400 V 3PH + N 50/60 HZ

### Options

- Nylon mesh cup-shaped pockets on request without extra cost
- Transfer conveyor

# Medio FA 10 Auto intermediate proofer with loading station

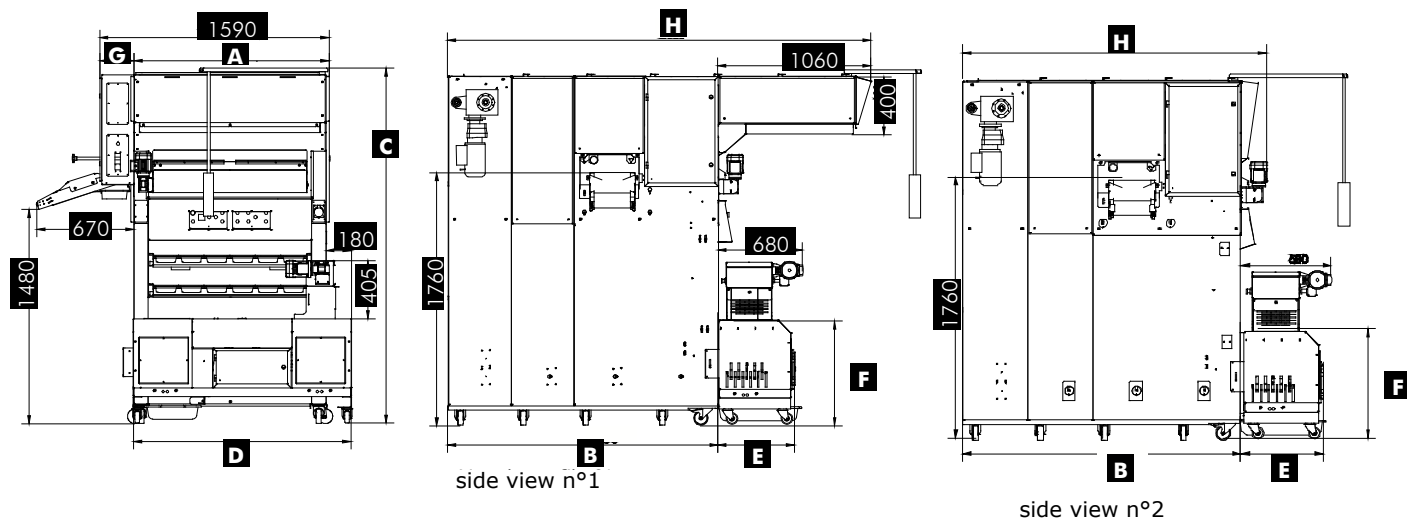

## Options

Conveyor on distributor

General features			FA10 650-6-62	FA10 650-6-74 FA10 1000-5-74	FA10 650-6-84 FA10 1000-5-84
Width of carriers	(mm)		1060	1060	1060
Number of carriers			62	74	84
Number of pockets (total)	650 g	Mini-Maxi	6/372	6/444	6/504
	1000 g	Mini-Maxi	5/310	5/370	5/420
Number of pockets (total)	650 g	Mini-Maxi	6/312	6/378	6/444
	1000	Mini-Maxi	5/260	5/315	5/370
Dough weight (total)	650 g	Mini-Maxi	80 - 650	80 - 650	80 - 650
	1000	Mini-Maxi	-	80 - 1000	80 - 1000
<b>Drawing, Side, View</b>			<b>2</b>	<b>1</b>	<b>2</b>
A	(mm)		1350	1350	1350
B	(mm)		1440	1440	1870
C	(mm)		2460	2460	2460
D - loading station	(mm)		1510	1510	1510
E - loading station	(mm)		530	530	530
F - loading station	(mm)		710	710	710
G - control panel	(mm)		240	240	240
H	(mm)		1610	2500	2050
Net weight Medio only *	(kg)		850	950	1000
Net weight distributor	(kg)		150	150	150
Puissance Médio seule	(kW)		0,95	0,95	0,95
Electrical power - including all options - with DVP, Major and TE	(kW)		3,6	3,6	3,6

## Packing for Models FA 10

	Model FA 10		FA10 650-6-62	FA10 650-6-74 FA10 1000-5-74	FA10 650-6-84 FA10 1000-5-84
<b>Mainland or By sea : (Wooden Crate)</b>	Width	(mm)	1900	1900	1900
	Length	(mm)	2650	2650	2650
	Height	(mm)	1800	1800	1800
	Weight	(kg)	1245	1300	1350



# Medio FA 12 Auto intermediate proofer with loading station

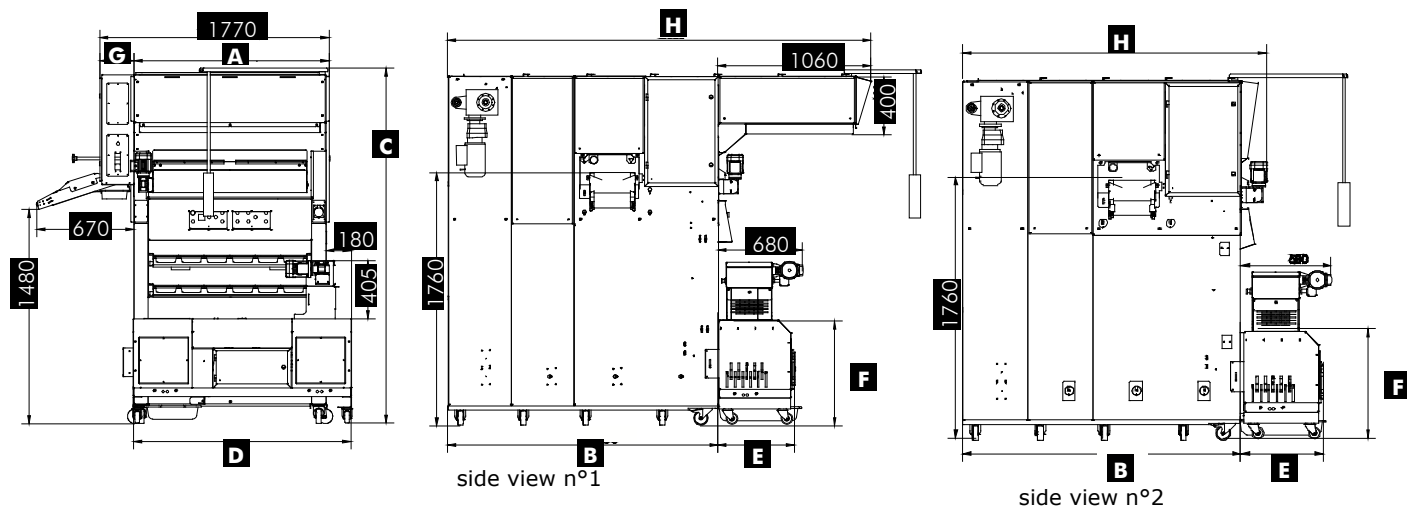

		<b>FA12 650-7-62</b>	<b>FA12 650-7-74</b>	<b>FA12 650-7-84</b>
<b>General features</b>		<b>FA12 1000-6-62</b>	<b>FA12 1000-6-74</b>	<b>FA12 1000-6-84</b>
Width of carriers	(mm)	1240	1240	1240
Number of carrier		62	74	84
Number of pockets ( total)	650	7/434	7/518	7/588
	1000	6/372	6/444	6/504
Number of pockets (usefull)	650	7/364	7/441	7/518
	1000	6/312	6/378	6/444
Dough weight mini-maxi (g)	650	80 - 650	80 - 650	80 - 650
	1000	80 - 1000	80 - 1000	80 - 1000
<b>Schéma. Vue de profil</b>		<b>2</b>	<b>1</b>	<b>2</b>
A	(mm)	1530	1530	1530
B	(mm)	1440	1440	1870
C	(mm)	2460	2460	2460
D - loadin station	(mm)	1690	1690	1690
E - loading station	(mm)	530	530	530
F - loading station	(mm)	710	710	710
G - control panel	(mm)	240	240	240
H	(mm)	1610	2500	2050
Net weight Medio only *	(kg)	900	1050	1100
Net weight distributor	(kg)	170	170	170
Power Medio only	(kW)	0,95	0,95	0,95
Electrical power - including all options - with DVP, Major and TE	(kW)	3,6	3,6	3,6

## Packing for Models FA 12

	Models FA 12		<b>FA12 650-7-62</b>	<b>FA12 650-7-74</b>	<b>FA12 650-7-84</b>
			<b>FA12 1000-6-62</b>	<b>FA12 1000-6-74</b>	<b>FA12 1000-6-84</b>
<b>Mainland or By sea : (Wooden Crate)</b>	Width	(mm)	1900	1900	1900
	Length	(mm)	2650	2650	2650
	Height	(mm)	1800	1800	1800
	Weight	(kg)	1245	1300	1350



## Dynamic intermediate proofer

### Performances

- 4 models and 4 configurations available for each model
- Total number of usefull pockets: 168 to 376, depending on models
- Dough piece weight: from 200 to 1000g
- Output: from 900 to 1500 p/h

### Use

The IK intermediate proofer is used in automatic bread plants. It provides the resting step of the dough pieces after dividing and rounding operations and prior to forming. This intermediate proofing period favours gluten relaxation and thus produces dough that is easier to mould. The machine allows the continuity of the production cycle at a programmed speed.

The extent of the range of available IK models can meet different requirements in terms of resting time needed for the dough pieces.

The intermediate proofer can be fed either by a BC conical rounder or directly by a DVP volumetric divider with built-in pre-rounding device.

The Major Alpha Auto moulder, set atop the outfeed conveyor TE, is usually connected at the discharge end of the proofer.

### Operating principle

The loader places the dough pieces – once divided – in nylon mesh pockets. A photocell detects the dough piece at the entrance room and makes automatically move the carrier of one level in order to receive the next dough piece in a free pocket

The dough pieces are transferred from one pocket to the other at each revolution of the carriers until the final discharge.

Once the cycle is completed and every pockets full, the last dough piece is unloaded automatically from the carriers onto the moulder.

Integrated in a bread plant, one single operator is able to operate the IK into discontinuous and continuous mode.

### Construction

- Outside panels in stainless steel
- Support structures in hot-painted steel
- Inspection window
- Carrier frames in galvanized steel tubes
- Pockets made of nylon mesh
- Carriers driven by a chain
- Motor controlled by an electronic dimmer that allows a very smooth and silent movement of the carriers
- Centralized control of the bread plant
- UV lamps to prevent mold
- Humidity extractor
- Entry flour duster
- Felt lined dough piece transfer device
- Low voltage electrical control board : 24 V
- Supply voltage: 400 V 3 PH + N 50 Hz

### The advantages

- A wide range of storage (from 168 to 376 pockets)
- Comfort:
  - Centralized control of the bread plant
  - Silent
  - Inspection window
  - Automatic resting cycle
- Hygiene:
  - UV lamps to prevent mold
  - Smooth surface and outside panels in stainless steel
- No sticking of dough pieces:
  - Entry flour duster
  - Humid air removal fan
  - Felt lined dough piece transfer device
  - Pockets mad of nylon mesh

# IK Dynamic intermediate proofer

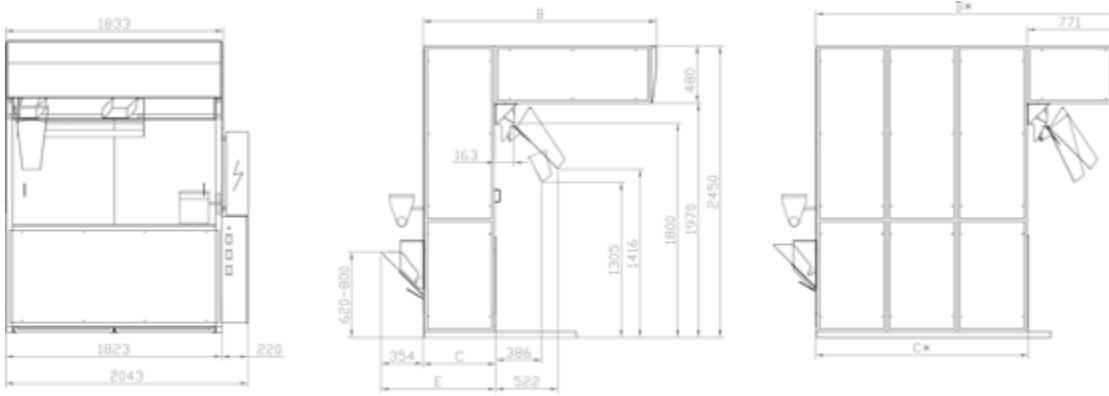

Models	IK 168	IK 216	IK 296	IK 376
<b>Total number of pockets</b>				
184	■	❖	❖	❖
232	❖	■	❖	❖
312	❖	❖	■	❖
392	❖	❖	❖	■
<b>Entry and exit position</b>				
	To be selected: 1,2,3 or 4			
<b>Equipment</b>				
Humid air removal fan	■	■	■	■
Entry flour duster	■	■	■	■
<b>Hygiene</b>				
UV lamp	■	■	■	■
Stainless steel outside panels	■	■	■	■
<b>Assemblage</b>				
Delivered assembled	■	■	■	■
Delivered unassembled	On request			
<b>Supply voltage</b>				
400V TRI+N+T 50Hz	■	■	■	■
■ standard ❖ Not available				

Possible configurations

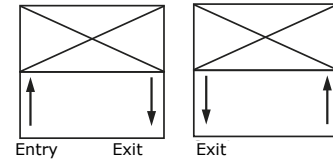

1

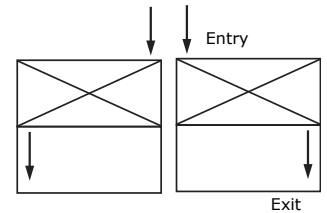

3

General features		IK 168	IK 216	IK 296	IK 376
<b>Filling capacity</b>					
Total number of pockets		184	232	312	392
Total number of useful pockets		168	216	296	376
Number of pockets per carrier		8	8	8	8
<b>Calculation of the resting time in minutes ( continuous mode)</b>					
Speed of	900 p/h	11,2	14,4	19,7	25
	1200 p/h	8,4	10,8	14,8	18,8
	1500 p/h	6,7	8,6	11,8	15
<b>Electrical power</b>					
Note: the electrical power of the other machines connected must be added	(kW)	0.6	0.6	0.6	0.6
<b>Dimensions and weight</b>					
B	(mm)	1370	1970	1970	2550
C	(mm)	600	600	1200	1200
E	(mm)	950	950	1550	1550
Poids	(kg)	650	690	930	980

## Packing

		Model	IK 168	IK 216	IK 296	IK 376
<b>Mainland (latticed crate)</b>	Width	(mm)	2020	2250	2340	2340
	Length	(mm)	2400	2700	2860	2860
	Height	(mm)	2200	2100	2290	2720
	Weight	(kg)	800	940	1110	1210

# Major



## Inclined Moulder

### Performances

- Models: 3
- Dough piece weight: from 80 to 1000g
- Output: up to 2000 p/h

### The advantages

- For all types of dough, even dry
- Easy to use
- Robust
- Reliable
- Quiet running (58 dBA)
- The security of the machine has been audit by an independent organism

### Use

The Major moulders are designed to mould and lengthen the dough pieces of all types of bread (baguettes, buns, country loaves, etc.). With their variants and options, they can be adapted on a foot, a piece of dough support, a table or an evacuation conveyor and can be perfectly integrated to groups of semi-automatic and automatic intermediate proofers. The machine's comfort of use is favoured by the regrouping of control and safety functions. Settings are easy using ergonomic handles fitted with indicators. The low noise level (58 dBA) allows work in a calm atmosphere.

### Operating principle

Centred by the hopper (Major) or driven by a feeding belt (Major Alpha) the dough piece is sheeted between two cylinders with anti-adherent coating then rolled under a heavy belt. The use of a tilting feeding belt, variable from horizontal to 40° (Major Alpha), speeds up the sheeting process. The pieces of dough undergo a soft and progressive lengthening between two woollen felt belts, turning in opposite direction, then are delivered on a folding felted tray (Manu and Alpha Manu).

### Construction

- Cast aluminium frame
- Fired, epoxy painted cladding and in-feed chute
- ABS casing
- Grooved belt drive
- Quiet running
- Right-hand control on standard
- Electrical control box on Manu and Standard model, optional on Auto
- Optional left-hand electrical controls, pinning and stretching
- Supply voltage : 3 PH + N 400 V 50/60 Hz

# Major inclined moulder

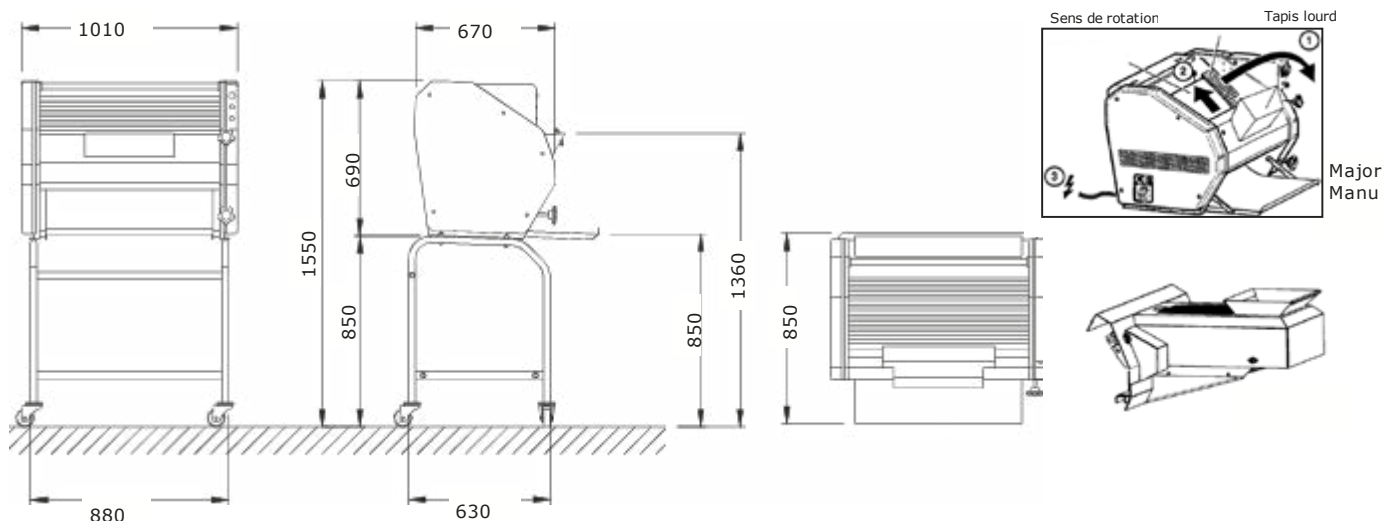

## Options

Electrical control for Major Auto (mandatory when installed on equipment not of Bongard production)

Felt drying fan only for MEDIO intermediate proofer

Manual and electrical control on the left

## General features

Models		Major Manu	Major Auto	Major Alpha Auto	Major Alpha Auto
Possible combination		On stand, table, RP chest type proofer	On Medio intermediate proofers	Delta 70 IK	Mada
Electronic control		Yes	Optional	Optional - obligatory for ECP	Yes
Dough piece loading	manual	Yes	No	Yes	Yes
	automatic	Yes	Yes	Yes	Yes
Dough piece loading	touch bar	Yes	No	Yes	Yes
Feed conveyor	450 mm	No	Yes	No	No
Dough piece outfeed	on outfeed tray	Yes	No	No	Yes
	on outfeed conveyor table	No	Yes	Yes	No
Performances	(p/h)	1500	1800	2000	1500
Dough piece weight	Mini-Maxi (g)	80 - 1000	80 - 1000	80 - 1000	80 - 1000
Motor power	(kW)	0,55	0,55	0,55	0,55
<b>Dimensions and weight</b>					
Width x depth	(mm)	1010 x 850	1010 x 1250	1010 x 780	1010 x 850
Height	(mm)	690	690	690	690
Loading height	(mm)	1360	1450	1350	1305
Output height	(mm)	850	940	940 (TE)	850
Net weight	(kg)	132	150	140	132

## Packing

Mainland (Cardboard box on pallet)	Model		Major Manu	Major Auto	Major Alpha Auto	Major Manu Mada
	Width	(mm)	1030	1030	1030	1030
	Length	(mm)	870	880	880	870
	Height	(mm)	880	1300	890	880
	Weight	(kg)	172	180	170	172
By sea : (Wooden Crate)	Model		Major Manu	Major Auto	Major Alpha Auto	Major Manu Mada
	Width	(mm)	1110	1110	1030	1110
	Length	(mm)	1060	1050	880	1060
	Height	(mm)	960	1300	890	960
	Weight	(kg)	210	240	170	210



## Outfeed conveyor belt for dough pieces

### Performances

- Models: 5
- Output: up to 2000 p/h

### Use

The TE outfeed conveyor belt supporting the Major moulder is designed to evacuate moulded dough pieces.

### Operating principle

Once shaped by the moulder, the lengthened dough pieces are firstly delivered to a felt tray then to the TE outfeed conveyor belt which, by the length and speed of the belt, allows to match the output of the bread plant.

### Construction

- In epoxy painted steel sheet
- Galvanised steel frame
- Non-stick, canvas belt
- Catch-pan for the moulded dough pieces
- Base on 4 castors and lock rams
- Electrical supply linked to the chamber (by the hanging control panel) on TE—Medio models
- Supply voltage : 400 V 3 PH + N 50 Hz

### The advantages

- Ideally used with an intermediate proofer
- Easy to use
- Time saving in the handling of dough pieces

# TE outfeed conveyor belt for dough pieces

<b>Models</b>	
<b>Models for Medio without electrical control panel</b>	
1 TE—Medio	
2 TE—Medio	
3 TE—Medio	
4 TE—Medio	
5 TE—Medio	

<b>Models</b>	
<b>Models for RTM before 96, ECP or machines from competitors— TE with electrical control panel</b>	
1 TE—Major	
2 TE—Major	
3 TE—Major	
4 TE—Major	
5 TE—Major	

<b>General features</b>						
<b>Models</b>		<b>1 TE</b>	<b>2 TE</b>	<b>3 TE</b>	<b>4 TE</b>	<b>5 TE</b>
Power	(kW)	0,09	0,09	0,09	0,09	0,09
<b>Dimensions and weight</b>						
Overall -- D x W	(mm)	1150 x 930	1850 x 930	2450 x 930	3250 x 930	4000 x 930
Height	(mm)	880	880	880	880	880
Usefull overall -- D x W	(mm)	530 x 690	1240 x 690	1950 x 690	2660 x 690	3370 x 690
Net weight	(kg)	85	110	140	160	180

<b>Packing</b>							
<b>Mainland (Cardboard box on palett)</b>	<b>Model</b>		<b>1 TE</b>	<b>2 TE</b>	<b>3 TE</b>	<b>4 TE</b>	<b>5 TE</b>
	Width	(mm)	1560	1860	2600	3400	4000
	Length	(mm)	950	950	950	950	950
	Height	(mm)	590	590	590	590	590
	Weight	(kg)	142	175	200	250	300
<b>By sea : (Wooden Crate)</b>	<b>Model</b>		<b>1 TE</b>	<b>2 TE</b>	<b>3 TE</b>	<b>4 TE</b>	<b>5 TE</b>
	Width	(mm)	1560	1860	2600	3400	4000
	Length	(mm)	950	950	950	950	950
	Height	(mm)	590	590	590	590	590
	Weight	(kg)	142	175	200	250	300

# Paneotrad®



## Performances

### Cycle time of :

- Indicative time between the boot cycles (action green button) and the end of work (green light off)
- Equalization + simple cutout : 48 s
- Simple cutout : 30 s
- Equalization+ dual cutout : 76 s
- Dual cutout : 67 s
- Equalization : 22 s

## The advantages

- Exceptional bread-making quality
- Save time in the manufacturing process
- «Just in time» production
- Wide variety of shapes:
  - 30 matrices available
  - Over 60 shapews possible
- Simple and ergonomic use
- Helps staff to be multi-functional
- Better quality of life at work
- Compact, fits into the smallest baking surfaces
- Easy cleaning
- Significantly limits the spread of flour dust
- Safety audited by an independent body

## Use

Paneotrad is a machine originally designed to make traditional style breads. It is now adapted to all types of bread-making in which the priority goes to finding a relatively irregular structured bread crumb (with large holes). Revolutionary in its concept, the use of Paneotrad respects the dough's structure, without degassing or using stressful operations involved in traditional dough dividing and moulding. The crumb is well-structured, more resistant, while remaining soft, elastic and remarkable in flavour.

Paneotrad® is a simple, multi-purpose machine which provides a wide range of working solutions, both in various manufactured product forms and in the bread-making process itself.

With the Paneotrad®Evo model, even more product forms are available as users can remove a die from the die holder very quickly on their own.

## Operating principle

The user starts by positioning the «dividing tray» which contains the dough (previously stored in the tray at 4°C for 24 to 72 hours) inside Paneotrad®.

Then he selects the working mode he wants: forming, or simple equalisation. (A 3rd «cleaning» mode is also available.)

Before he launches the working cycle, the user chooses the dividing combination from the 6 possibilities provided by the 3 dies (that are fitting the die holder) and determines the equalisation pressure to be applied to the dough: «hard dough», «soft dough» or «no equalisation».

When the Paneotrad® working cycle is complete, the shaped dough pieces may be sent directly for baking.

## Construction

- Matrices, tray and dividing tray made from a polymer material suitable for contact with foodstuffs
- 1 clear and balanced access gate, 1 matrix viewing window
- Mounted on swivel wheels
- Stainless steel corner columns, gate frames and spacers
- Painted sheet steel lining panel
- Electro-mechanical control panel

## Accessories :

- A mould remover which enables the dividing tray to be taken out of the mould remover is delivered as standard
- A trolley equipped with a flour duster and a folding tray is available as an option. The flour duster's ergonomic height enables the flour to be spread evenly over the dough.
- Un support de rangement des matrices amovibles et des bacs de découpe à intégrer sur la machine ou en version murale.



	<b>Paneotrad®</b>	<b>Paneotrad® Evo</b>
	<b>Pack</b>	<b>Pack</b>
<b>Configuration</b>		
Paneotrad®	■	■
Forming dies	Fixed	Removable
Number of forming dies	Choice of 3	Choice of 4
Choice of cutting high -sided trays: 3 (fixed or removable, mix)	■	■
Mould remover	■	■
<b>Power supply</b>		
400V TRI+N+T 50Hz	■	■

Die no. 1 : 10 dough blocks of 57 x 375 mm	<input type="checkbox"/>	<input type="checkbox"/>
Die No. 2 : 6 dough blocks of 570 x 62.5 mm	<input type="checkbox"/>	<input type="checkbox"/>
Die No. 3 : 15 dough blocks (5x3) of 114 x 125 mm	<input type="checkbox"/>	<input type="checkbox"/>
Die No. 4 : 8 dough blocks of 570 x 47 mm	<input type="checkbox"/>	<input type="checkbox"/>
Die No. 5 : 24 dough blocks (4x6) of 142.5 x 62.5 mm	€	€
Die No. 6 : 8 dough blocks of 71.5 x 375 mm	<input type="checkbox"/>	<input type="checkbox"/>
Die No. 7 : 12 dough blocks of 47.5 x 375 mm	<input type="checkbox"/>	<input type="checkbox"/>
Die No. 8 : 12 dough blocks (4x3) of 142.5 x 125 mm	<input type="checkbox"/>	<input type="checkbox"/>
Die No. 9 : 4 dough blocks 142.5 x 375 mm	<input type="checkbox"/>	<input type="checkbox"/>
Die No. 10 : 24 dough blocks (12x2) of 47.5 x 187.5 mm	€	€
Die No. 11 : 12 dough blocks (2x6) of 285 x 62.5 mm	<input type="checkbox"/>	<input type="checkbox"/>
Die No. 12 : 20 dough blocks (4x5) of 142.5 x 75 mm	€	€
Die No. 13 : 8 dough blocks (4x2) of 142.5 x 187.5 mm	<input type="checkbox"/>	<input type="checkbox"/>
Die No. 14 : 32 dough blocks (4x8) of 142.5 x 46.8 mm	€	€
Die No. 15 : 10 dough blocks (5x2) of 114 x 187.5 mm	<input type="checkbox"/>	<input type="checkbox"/>
Die No. 16 : 4 dough blocks (2x2) of 285 x 187.5 mm	<input type="checkbox"/>	<input type="checkbox"/>
Die No. 17 : 11 dough blocks of 52 x 375 mm	<input type="checkbox"/>	<input type="checkbox"/>
Die No. 18 : 6 dough blocks (3x2) of 190 x 187.5 mm	<input type="checkbox"/>	<input type="checkbox"/>
Die No. 19 : 15 dough blocks (3x5) of 190 x 75 mm	<input type="checkbox"/>	<input type="checkbox"/>
Die No. 20 : 12 dough blocks (6x2) of 95 x 187.5 mm	<input type="checkbox"/>	<input type="checkbox"/>
Die No. 21 : 18 dough blocks(3x6) of 190 x 62.5 mm	€	€
Die No. 22 : 16 dough blocks (2x8) of 285 x 46.8 mm	€	€
Die No. 23 : 24 dough blocks (6x4) of 95 x 94 mm	€	€
Die No. 24 : 16 dough blocks (8x2) of 71.5 x 187.5 mm	€	€
Die No. 28 : 25 dough blocks (5x5) of 114 x 75 mm	€	€
Die No. 36: 4 dough blocks of 570 x 93,5 mm	<input type="checkbox"/>	<input type="checkbox"/>
Die No. 37: 6 dough blocks of 95 x 375 mm	<input type="checkbox"/>	<input type="checkbox"/>
Die No. 38: 3 dough blocks of 570 X 125 mm	<input type="checkbox"/>	<input type="checkbox"/>
Die No. 41: 6 dough blocks of 285 X 125 mm	<input type="checkbox"/>	<input type="checkbox"/>
Die No. 42 : 30 dough blocks of 114 x 125 X 169 mm Operates in double cutout with Die No. 3 only	<input type="checkbox"/>	<input type="checkbox"/>
Die No. 43: 20 dough blocks of 114 X 187.5 X 219.5 mm Operates in double cutout with matrix No. 15 only	<input type="checkbox"/>	<input type="checkbox"/>
Die No. 44: 15 dough blocks Ø internal = 95 mm Ø outside = 110 mm	**	<input type="checkbox"/>
Die No. 45: 25 dough blocks Ø internal = 75 mm Ø outside = 90 mm	**	<input type="checkbox"/>
Die no. 48 : 10 dough "round ends" blocks of 57 x 375 mm	**	<input type="checkbox"/>

## Paneotrad : Accessories

	<i>Forming dies for Paneotrad®</i>	<i>Forming dies for Paneotrad® Evo</i>
Die no. 1 : 10 dough blocks of 57 x 375 mm	€	€
Die No. 2 : 6 dough blocks of 570 x 62.5 mm	€	€
Die No. 3 : 15 dough blocks (5x3) of 114 x 125 mm	€	€
Die No. 4 : 8 dough blocks of 570 x 47 mm	€	€
Die No. 5 : 24 dough blocks (4x6) of 142.5 x 62.5 mm	€€	€€
Die No. 6 : 8 dough blocks of 71.5 x 375 mm	€	€
Die No. 7 : 12 dough blocks of 47.5 x 375 mm	€	€
Die No. 8 : 12 dough blocks (4x3) of 142.5 x 125 mm	€	€
Die No. 9 : 4 dough blocks 142.5 x 375 mm	€	€
Die No. 10 : 24 dough blocks (12x2) of 47.5 x 187.5 mm	€€	€€
Die No. 11 : 12 dough blocks (2x6) of 285 x 62.5 mm	€	€
Die No. 12 : 20 dough blocks (4x5) of 142.5 x 75 mm	€€	€€
Die No. 13 : 8 dough blocks (4x2) of 142.5 x 187.5 mm	€	€
Die No. 14 : 32 dough blocks (4x8) of 142.5 x 46.8 mm	€€	€€
Die No. 15 : 10 dough blocks (5x2) of 114 x 187.5 mm	€	€
Die No. 16 : 4 dough blocks (2x2) of 285 x 187.5 mm	€	€
Die No. 17 : 11 dough blocks of 52 x 375 mm	€	€
Die No. 18 : 6 dough blocks (3x2) of 190 x 187.5 mm	€	€
Die No. 19 : 15 dough blocks (3x5) of 190 x 75 mm	€	€
Die No. 20 : 12 dough blocks (6x2) of 95 x 187.5 mm	€	€
Die No. 21 : 18 dough blocks(3x6) of 190 x 62.5 mm	€€	€€
Die No. 22 : 16 dough blocks (2x8) of 285 x 46.8 mm	€€	€€
Die No. 23 : 24 dough blocks (6x4) of 95 x 94 mm	€€	€€
Die No. 24 : 16 dough blocks (8x2) of 71.5 x 187.5 mm	€€	€€
Die No. 28 : 25 dough blocks (5x5) of 114 x 75 mm	€€	€€
Die No. 36: 4 dough blocks of 570 x 93,5 mm	€	€
Die No. 37: 6 dough blocks of 95 x 375 mm	€	€
Die No. 38: 3 dough blocks of 570 X 125 mm	€	€
Die No. 41: 6 dough blocks of 285 X 125 mm	€	€
Die No. 42 : 30 dough blocks of 114 x 125 X 169 mm Operates in double cutout with Die No. 3 only	€	€
Die No. 43: 20 dough blocks of 114 X 187.5 X 219.5 mm Operates in double cutout with matrix No. 15 only	€	€
Die No. 44: 15 dough blocks Ø internal = 95 mm Ø outside = 110 mm	**	€
Die No. 45: 25 dough blocks Ø internal = 75 mm Ø outside = 90 mm	**	€
Die no. 48 : 10 dough "round ends" blocks of 57 x 375 mm	**	€

☐ € standard price / ☐ € € price with extra cost / - Not available

• Fixed dies are only compatibles with Paneotrad® and incompatible with Paneotrad® Evo  
Installation of a dies requires a technician

• Removable dies are only comptabile with Paneotrad® Evo and incompatible with Paneotrad®  
The user can change the die himself

# Paneotrad

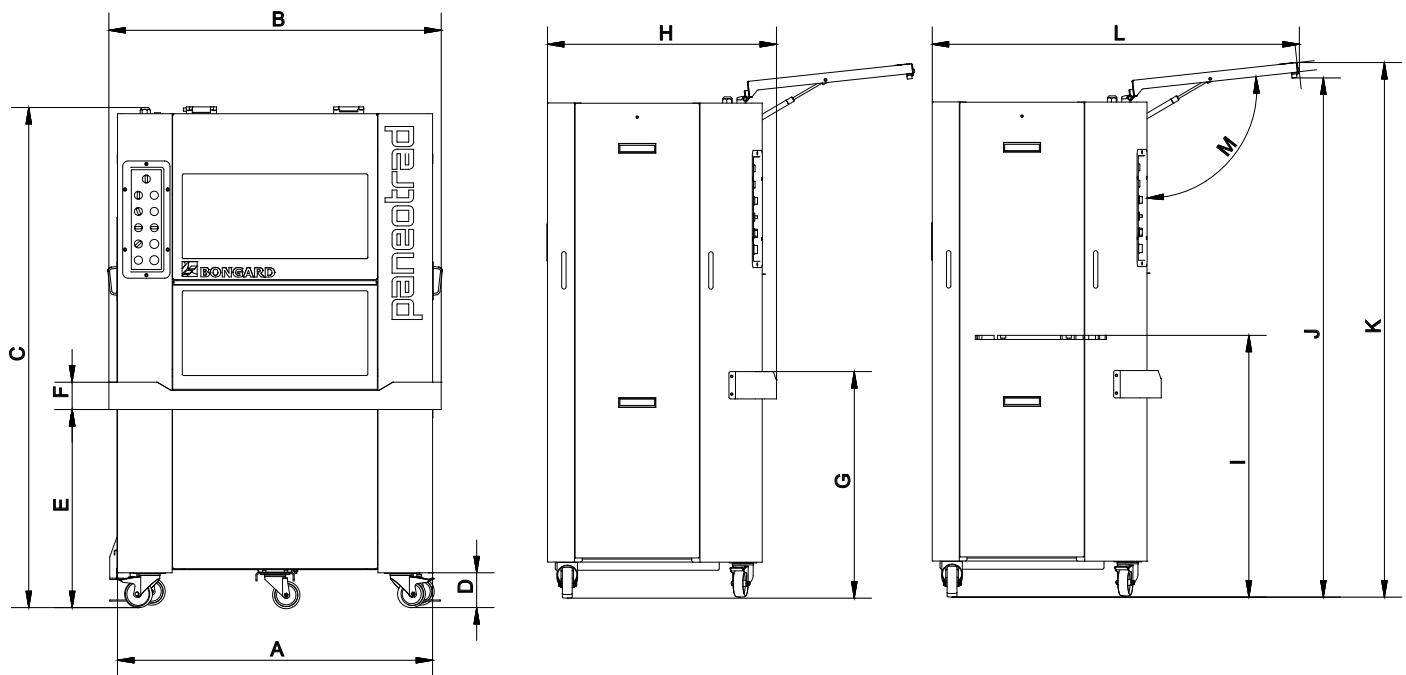

## General features

Model		Paneotrad®	Paneotrad® Evo
Connecting power	(kW)	1	1
Net weight with standard equipment	(kg)	380	425

## Dimensions of Paneotrad® and Paneotrad® Evo (mm)

A	B	C	D	E	F	G	H	I	J	K	L	M
1150	1215	1825	130	725	100	825	840	950	1960	2020	1320	105°

## Packing

<b>Mainland (latticed crate)</b>	<b>Model</b>		<b>Paneotrad®</b>	<b>Paneotrad® Evo</b>
	Width	(mm)	1280	1280
	Length	(mm)	1040	1040
	Height	(mm)	2030	2030
<b>By sea : (Wooden Crate)</b>	<b>Model</b>		<b>Paneotrad®</b>	<b>Paneotrad® Evo</b>
	Width	(mm)	1280	1280
	Length	(mm)	1040	1040
	Height	(mm)	2030	2030
	Weight	(kg)	410	410

## Paneotrad : Accessories

---

Dividing and moulding tub (fixe)	€
Dividing and moulding tub (removable)	€
Mobile tub storage table with flour duster, stainless steel top	€
Mobile tub storage table with flour duster, wooden top	€
Mobile tub storage table with flour duster and tilting shelf	€
Mobile tub storage table without flour duster	€
Holder for 2 removable dies and 2 tubs, to hang on the machine	€
Wall-mounted holder for 2 removables dies and 2 tubs	€
Mould remover	€
Plastic dough storage tub H95 mm	€
Plastic dough storage tub H75 mm	€
Rack for 14 storage tubs H95 mm (Entry 400, suitable BFM 400 X 600)	€
Rack for 17 storage tubs H75 mm (Entry 400, suitable BFM 400 X 600)	€
Rack for 2x14 storage tubs H95 mm (Entry 600, suitable BFM 600 X 800)	€
Rack for 2x17 storage tubs H75 mm(Entry 600, suitable BFM 600 X 800)	€
Racks for 14 storage tubs H95 mm (Entry 600, suitable BFM 600 X800)	€
Racks for 17 storage tubs H75 mm (Entry 600, suitable BFM 600 X800)	€
Non stick fiberglass mat, Teflon coated, 400 x 600 mm	€

- Fixed dies are only compatibles with Paneotrad® and incompatible with Paneotrad® Evo  
Installation of a dies requires a technician
- Removable dies are only comptabile with Paneotrad® Evo and incompatible with Paneotrad®  
The user can change the die himself

## Paneotrad : Accessories

### Mobile tub storage table with flour duster & raised foldable extension

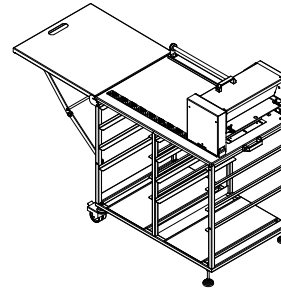

- At ergonomic height, the flour duster spreads the flour uniformly over the entire surface of the pan, preventing any sticking.
- The table offers an additional work area with a minimum footprint because it can be folded down into storage position. Note: position of the table is reversible.

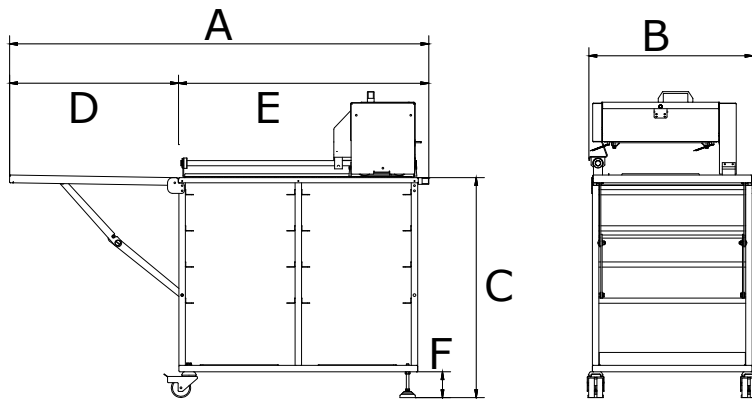

Dough tub storage table with flour duster and fold-away extension table					
A	B	C	D	E	F
- mm	635 mm	852 mm	654 mm	1015 mm	100 mm

Dough tub storage table with flour duster and extension table in working position					
A	B	C	D	E	F
1624 mm	635 mm	852 mm	654 mm	- mm	100 mm

Dough tub storage table with flour duster, without fold-away extension table					
A	B	C	D	E	F
- mm	635 mm	852 mm	- mm	950 mm	100 mm

#### Packing

<b>Mainland (latticed crate)</b>	<b>Model</b>		<b>dough tub storage table</b>
	Width	(mm)	980
	Length	(mm)	750
	Height	(mm)	1250
<b>By sea : (Wooden Crate)</b>	Weight	(kg)	60
	<b>Model</b>		<b>dough tub storage table</b>
	Width	(mm)	1080
	Length	(mm)	850
	Height	(mm)	1400
	Weight	(kg)	80

# Paneotrad : Accessories

## Dies and tubs holder



- Equipped with 2 handle grips, the holder is installed very quickly and instead of one of the 2 lateral panels of Paneotrad EvO
- It is possible to equip Paneotrad EvO with 2 holders on both sides of the machine.
- A version of the holder that can be fixed on a wall is available.

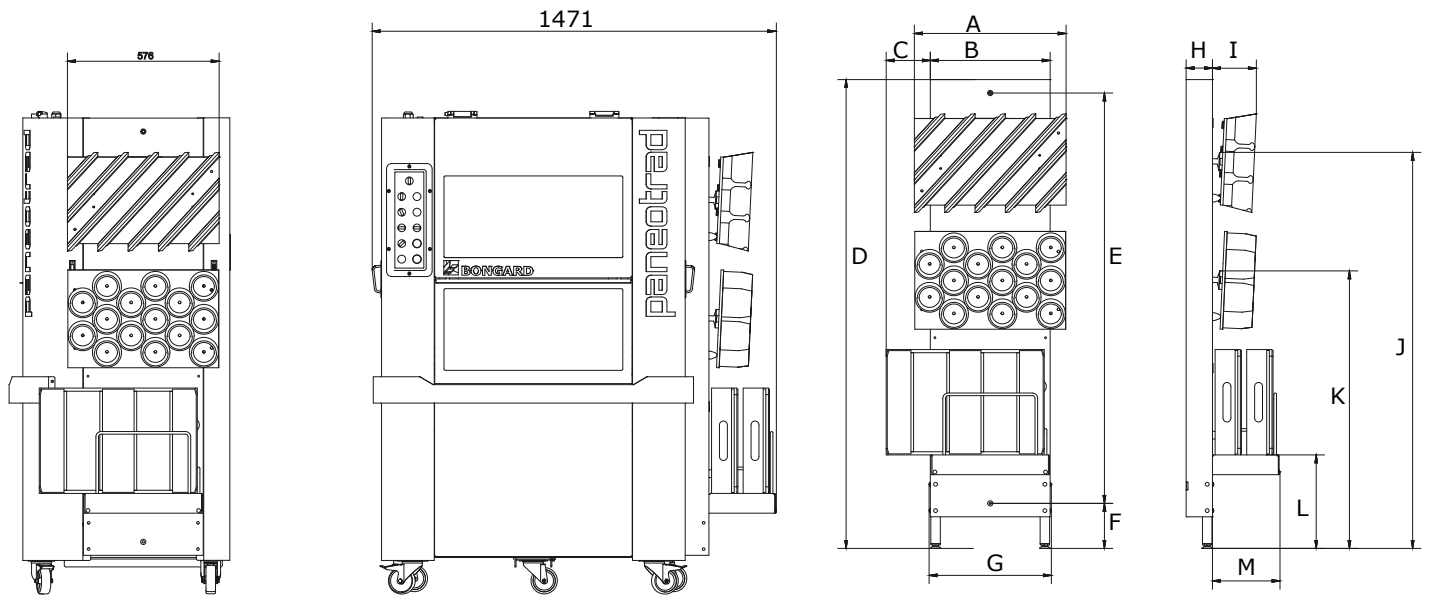

Dies and tubs holder

A	B	C	D	E	F	G	H	I	J	K	L	M
576 mm	455 mm	168 mm	1780 mm	1558 mm	171 mm	464 mm	100 mm	167 mm	1504 mm	1054 mm	355 mm	256 mm

# Paneotrad : Accessories

## Motorised flour duster Paneodust

- Stainless steel structure
- Steel protective cover
- Inspection window
- 1 ON/OFF button
- 2 sensors : 1 front sensor (beginning of flour dusting) and 1 rear sensor (end of flour dusting)
- 1 brush drive by a single-phase motor, rear power cable connection
- Flour tank with sliding door handle
- Removable sieve for an easy evacuation and cleaning of the flour duster

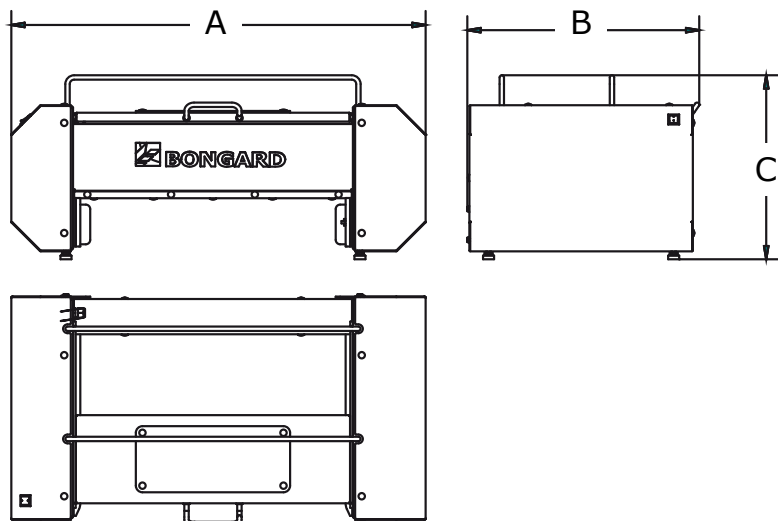

Dimensions (mm)	A	B	C
Paneodust	940	526,2	417,5

Packing			
	Model		Paneodust
Mainland (latticed crate)	Width	(mm)	1120
	Length	(mm)	720
	Height	(mm)	625
	Weight	(kg)	55

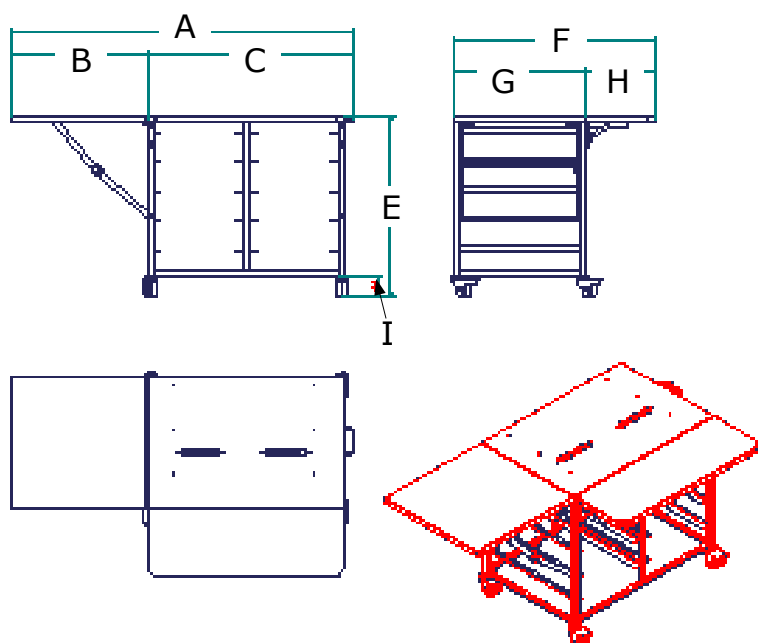

## Mobile tub storage table for Paneodust

The mobile tub storage table is dedicated to Paneodust.

- Stainless steel structure
- 4 castors with brake
- Rounded edges
- Fold away extension table, standard on the front
- Extension table on the left side, as option
- Fixing holes for Paneodust
- Cutouts under the duster to allow the evacuation of the flour
- Moving handle
- Storage for 10 tubs

Dimensions (mm)	A	B	C	E	F	G	H	I
Storage table	1633	652	981	854	953	625	328	102

# Paneotrad : Accessories

## Racks

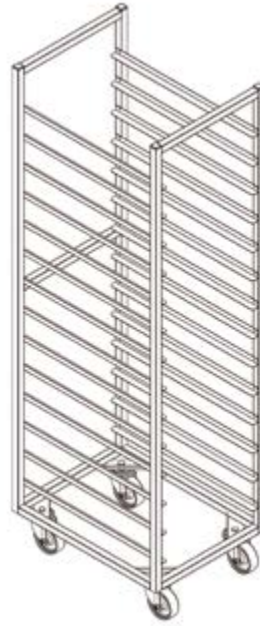
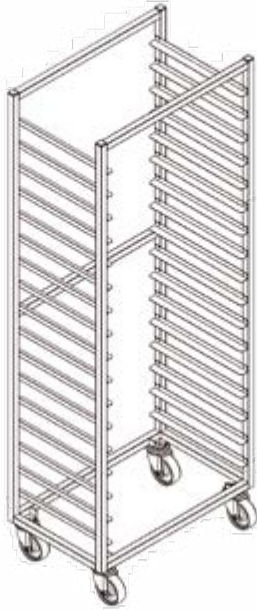

<i>Dimensions</i>	<i>Dough tub entry size</i>	<i>Width (mm)</i>	<i>Depth (mm)</i>	<i>Height (mm)</i>
17 bacs H75	400	460	605	1756
14 bacs H95	400	460	605	1756
17 bacs H75	600	670	410	1758
14 bacs H75	600	670	410	1758
2 x 17 Paneo H75	600	670	810	1788
2 x 14 Paneo H75	600	670	810	1788



### Packing

		<i>Model</i>	<i>Rack</i>
<i>Mainland (latticed crate)</i>	Width	(mm)	675
	Length	(mm)	530
	Height	(mm)	1785
	Weight	(kg)	20
		<i>Model</i>	<i>Rack</i>
<i>By sea : (Wooden Crate)</i>	Width	(mm)	775
	Length	(mm)	775
	Height	(mm)	1850
	Weight	(kg)	40



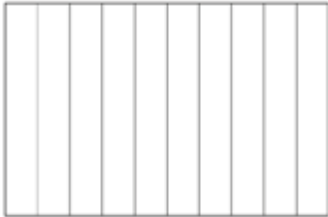
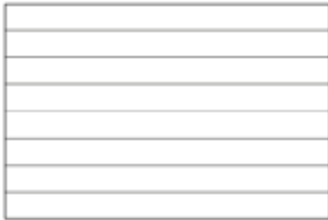
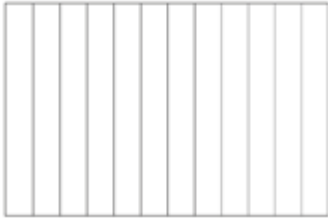

# SELECTION GUIDE OF FORMING DIE

## FRENCH BAGUETTES

N° die 1st cutout	N° die 2nd cutout	Number of pieces	Size of square (l x L in mm)	Drawing of square	Mini weight of pieces (g)	Mini weight of pieces (g)
<b>Single cut shapes</b>						
1	*	10	57 x 375		225	540
4	*	8	570 x 47		281	675
7	*	12	47,5 x 375		188	400
17	*	11	52 x 375		205	491

# SELECTION GUIDE OF FORMING DIE

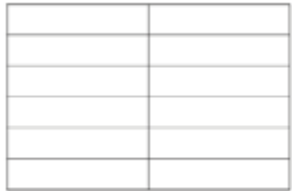
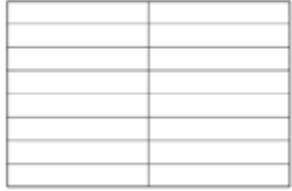
## SANDWICHES

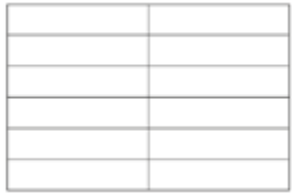
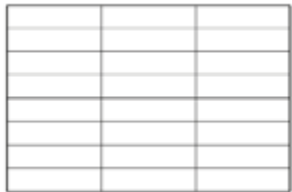
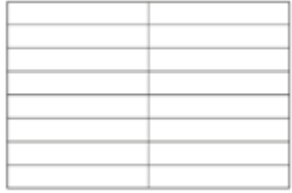
N° die 1st cutout	N° die 2nd cutout	Number of pieces	Size of square (l x l in mm)	Drawing of square	Mini weight of pieces (g)	Mini weight of pieces (g)
<b>Single cut shapes</b>						
10	*	24	47,5 x 187,5		94	200
11	*	12	285 x 62,5		188	450
22	*	16	285 x 47		141	338
24	*	16	71 x 187,5		113	270
<b>Dual cut shapes</b>						
1	15	20	57 x 187,5		113	270
1	16					
2	16	12	285 x 62,5		188	450
4	18	24	190 x 47		94	225
4	16	16	285 x 47		141	338

# SELECTION GUIDE OF FORMING DIE

## SANDWICHES

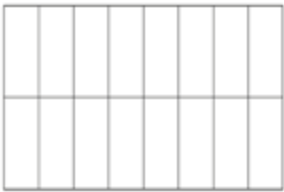
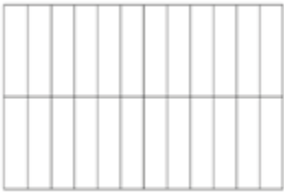
N° die 1st cutout	N° die 2nd cutout	Number of pieces	Size of square (l x L in mm)	Drawing of square	Mini weight of pieces (g)	Mini weight of pieces (g)
<b>Double cut shapes</b>						
6	13	16	71 x 187,5		141	338
6	16					
7	16	24	47,5 x 187.5		94	200
7	18					
7	20					

# SELECTION GUIDE OF FORMING DIE

## MEDIUM RECTANGULAR LOAVES

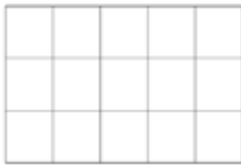
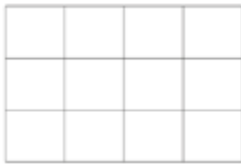
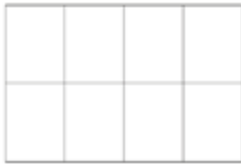
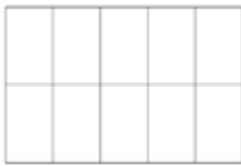
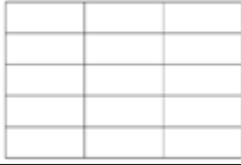
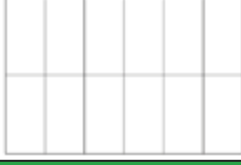
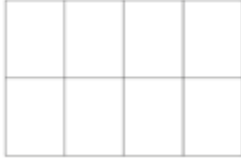
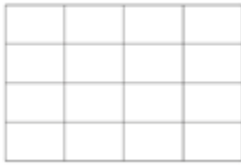
N° die 1st cutout	N° die 2nd cutout	Number of pieces	Size of square (l x L in mm)	Drawing of square	Mini weight of pieces (g)	Mini weight of pieces (g)
<b>Single cut shapes</b>						
3	*	15	114 x 125		150	450
8	*	12	142,5 x 125		188	600
13	*	8	142,5 x 187,5		281	900
15	*	10	114 x 187,5		255	720
19	*	15	190 x 75		150	400
20	*	12	95 x 187,5		188	500
<b>Dual cut shapes</b>						
9	16	8	142,5 x 187,5		281	900
9	36	16	142,5 x 93,5		141	425
13	36					

# SELECTION GUIDE OF FORMING DIE

## MEDIUM RECTANGULAR LOAVES

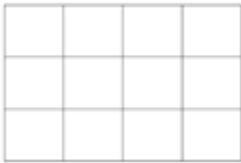
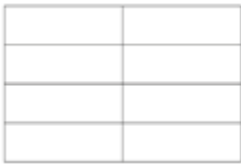
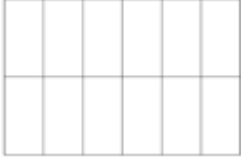
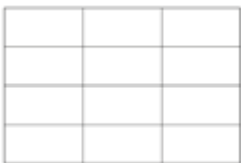
N° die 1st cutout	N° die 2nd cutout	Number of pieces	Size of square (l x L in mm)	Drawing of square	Mini weight of pieces (g)	Mini weight of pieces (g)
<b>Double cut shapes</b>						
9	38	12	142,5 x 125		188	600
9	41					
16	36	8	285 x 93,5		281	850
16	37	12	95 x 187,5		188	500
18	37					
18	36	12	190 x 93,5		188	567

# SELECTION GUIDE OF FORMING DIE

## LARGE RECTANGULAR LOAVES

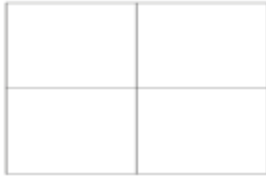
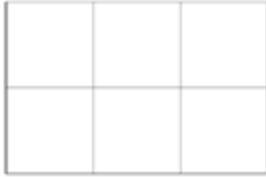
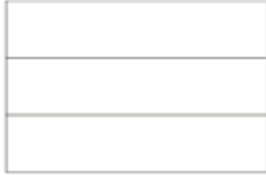
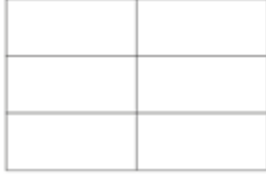
N° die 1st cutout	N° die 2nd cutout	Number of pieces	Size of square (l x L in mm)	Drawing of square	Mini weight of pieces (g)	Mini weight of pieces (g)
<b>Single cut shapes</b>						
9	*	4	142,5 x 375		563	1800
16	*	4	285 x 187,5		563	1800
18	*	6	190 x 187,5		375	1200
38	*	3	570 x 125		750	2400
41	*	6	285 x 125		375	1200

# SELECTION GUIDE OF FORMING DIE

## SMALL RECTANGULAR LOAVES

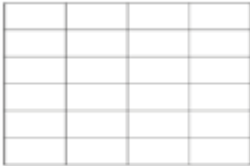
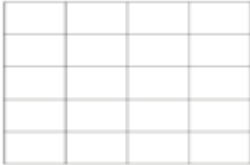
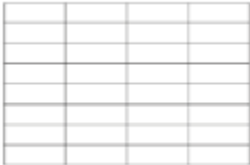
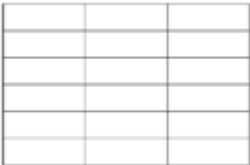
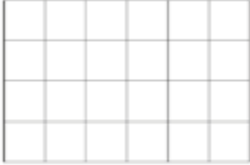
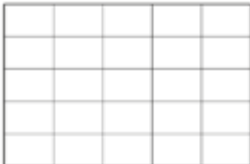
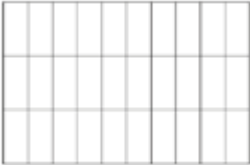
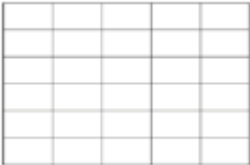
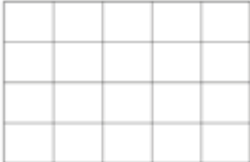
N° die 1st cutout	N° die 2nd cutout	Number of pieces	Size of square (l x L in mm)	Drawing of square	Mini weight of pieces (g)	Mini weight of pieces (g)
<b>Simple cut shapes</b>						
5	*	24	142,5 x 62,5		84	250
12	*	20	142,5 x 75		133	270
14	*	32	142,5 x 47		70	169
21	*	18	190 x 62,5		125	300
23	*	24	95 x 93,5		94	225
28	*	25	114 x 75		90	216
<b>Dual cut shapes</b>						
1	3	30	57 x 125		75	180
1	38					
2	3	30	114 x 62,5		75	180
2	15					
15	36	20	114 x 93,5		113	340

# SELECTION GUIDE OF FORMING DIE

## SMALL RECTANGULAR LOAVES

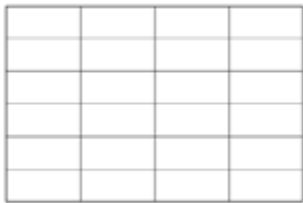
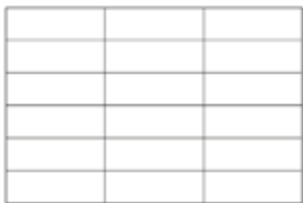
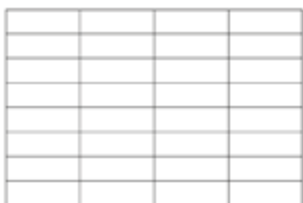
N° die 1st cutout	N° die 2nd cutout	Number of pieces	Size of square (l x L in mm)	Drawing of square	Mini weight of pieces (g)	Mini weight of pieces (g)
<b>Dual cut shapes</b>						
2	8	24	142,5 x 62,5		94	225
2	9					
2	13					
8	11					
9	11					
11	13					
2	18	18	190 x 62,5		125	300
4	9	32	142,5 x 47		70	169
4	13					
9	22					
13	22					





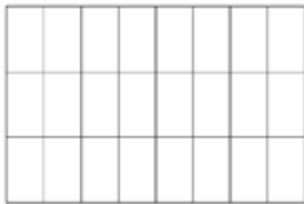
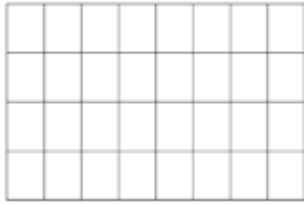
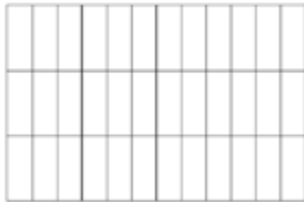
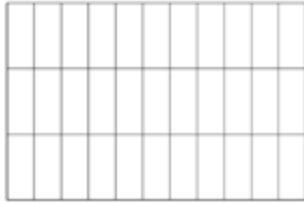
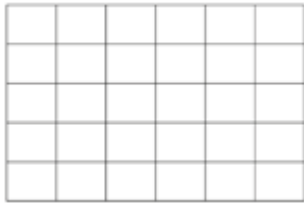
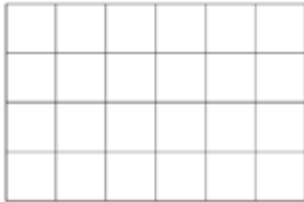
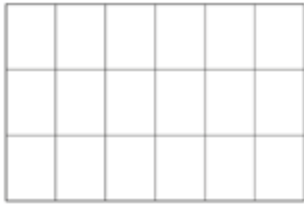

# SELECTION GUIDE OF FORMING DIE

## SMALL RECTANGULAR LOAVES

N° die 1st cutout	N° die 2nd cutout	Number of pieces	Size of square (l x L in mm)	Drawing of square	Mini weight of pieces (g)	Mini weight of pieces (g)
<b>Dual cut shapes</b>						
6	8	24	71 X 125		94	225
6	38					
6	41					
6	36	32	71 X 93,5		70	169
24	36					
7	8	36	47,5 X 125		63	133
7	38					
7	41					
17	38	33	52 x 125		68	164
19	37	30	95 x 75		75	200
20	36	24	95 x 93,5		94	225
36	37					
37	38	18	95 x 125		125	378
37	41					

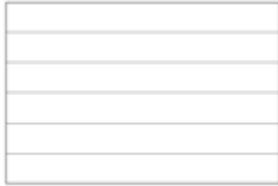
# SELECTION GUIDE OF FORMING DIE

## LARGE LOAVES

N° die 1st cutout	N° die 2nd cutout	Number of pieces	Size of square (l x L in mm)	Drawing of square	Mini weight of pieces (g)	Mini weight of pieces (g)
<b>Simple cut shapes</b>						
2	*	6	570 x 62,5		375	900
6	*	8	71 x 375		281	675
36	*	4	570 x 93,5		563	1700
37	*	6	95 x 375		375	1133

# SELECTION GUIDE OF FORMING DIE

## ROLLS

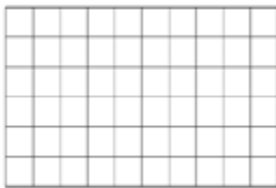
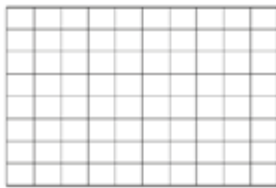
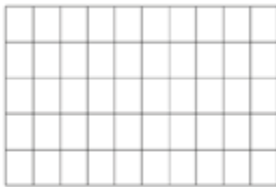
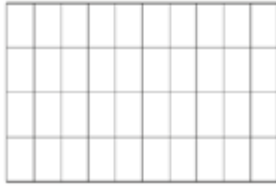
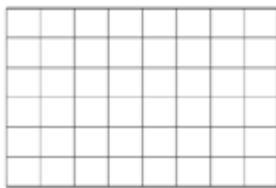
N° die 1st cutout	N° die 2nd cutout	Number of pieces	Size of square (l x L in mm)	Drawing of square	Mini weight of pieces (g)	Mini weight of pieces (g)
<b>Simple cut shapes</b>						
1	2	60	57 x 62,5		38	90
1	11					
1	4	80	57 x 47		28	68
1	22					
1	28	50	57 x 75		45	108
1	36	40	57 x 93,5		56	135
2	6	48	71 x 62,5		47	113
2	24					
5	6					
6	11					
11	24					

# SELECTION GUIDE OF FORMING DIE

## ROLLS

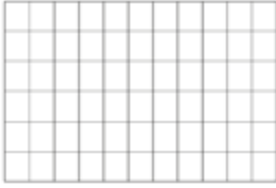
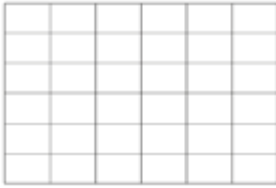
N° die 1st cutout	N° die 2nd cutout	Number of pieces	Size of square (l x L in mm)	Drawing of square	Mini weight of pieces (g)	Mini weight of pieces (g)
<b>Dual cut shapes</b>						
2	7	72	47,5 x 62,5		31	67
2	10					
5	7					
7	11					
7	21					
2	17	66	52 x 62,5		34	82
2	20	36	95 x 62.5		63	150
2	37					
11	20					
11	37					
21	37					

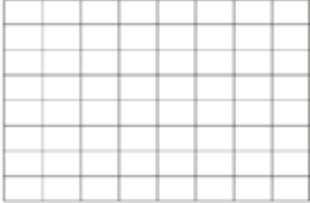
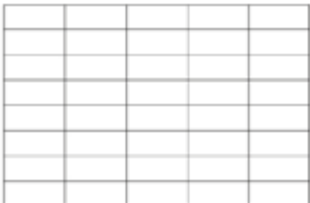
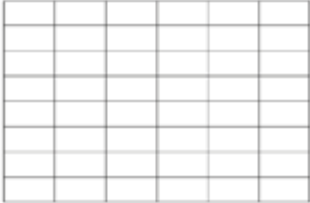
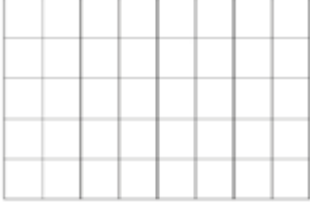

# SELECTION GUIDE OF FORMING DIE

## ROLLS

N° die 1st cutout	N° die 2nd cutout	Number of pieces	Size of square (l x L in mm)	Drawing of square	Mini weight of pieces (g)	Mini weight of pieces (g)
<b>Dual cut shapes</b>						
4	6	64	71 x 47		35	84
4	24					
6	14					
6	22					
14	24					
4	15	40	114 x 47		56	135
4	20	48	95 x 47		47	113
4	37					
22	23					
22	37					
6	12	40	71 x 75		56	135

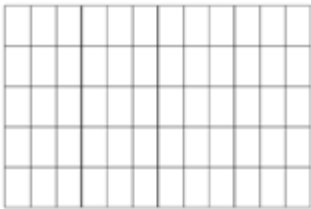
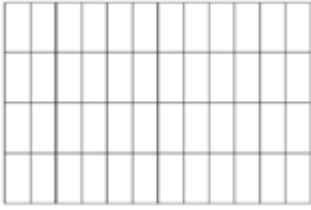

# SELECTION GUIDE OF FORMING DIE

## ROLLS

N° die 1st cutout	N° die 2nd cutout	Number of pieces	Size of square (l x L in mm)	Drawing of square	Mini weight of pieces (g)	Mini weight of pieces (g)
<b>Dual cut shapes</b>						
7	12	60	47,5 x 75		38	80
7	19					
7	23	48	47,5 x 93,5		47	100
7	36					
10	23					
10	36					
17	36	44	52 x 93,5		51	123

# SELECTION GUIDE OF FORMING DIE

## TRIANGULAR SHAPES

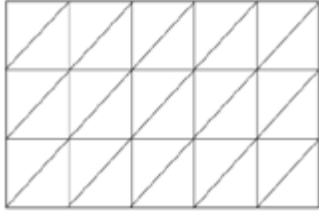
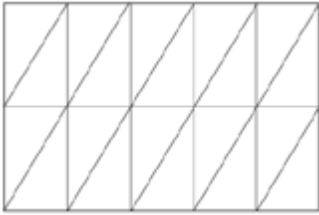
N° die 1st cutout	N° die 2nd cutout	Number of pieces	Size of square (l x L in mm)	Drawing of square	Mini weight of pieces (g)	Mini weight of pieces (g)
<b>Single cut shapes</b>						
42	*	Works with die No.3 No use in single cut			75	227
43	*	Works with die No.15 No use in single cut			113	360
<b>Dual cut shapes</b>						
42	3	30	114 x 125 x 169		75	227
43	15	20	114 x 187,5 x 219,5		113	360

# SELECTION GUIDE OF FORMING DIE

## «Round bread» dies

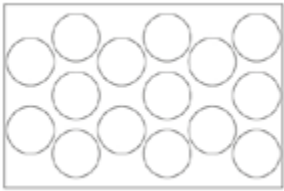
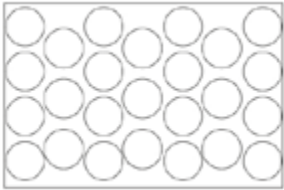
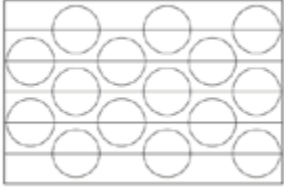
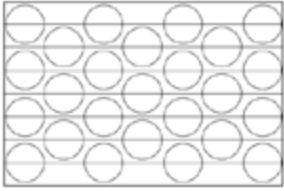
N° die 1st cutout	N° die 2nd cutout	Number of pieces	Size of square (l x L in mm)	Drawing of square	Mini weight of pieces (g)	Mini weight of pieces (g)
<b>Single cut shapes</b>						
44	*	15	Ø95-110		75	200
45	*	25	Ø75-90		45	108
<b>Dual cut shapes</b>						
44	2	30	Ø95-110		38	100
45	4	50	Ø75-90		23	54

## «Round Ends» dies

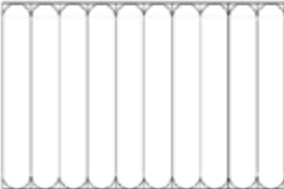
N° die 1st cutout	N° die 2nd cutout	Number of pieces	Size of square (l x L in mm)	Drawing of square	Mini weight of pieces (g)	Mini weight of pieces (g)
<b>Single cut shapes</b>						
48	*	10	57 x 375		220	250



# Rhea



## Dough sheeters

### Characteristics

- Belt width : 500 / 600 mm
- Table length: 750, 1000, 1400 mm
- Table top or floor type models
- Rhea 600 LC: with cutting station

NEW

- 600LC model is available with a **roller gap digital display**
- **SmartBlue Technology**, washable, antistatic and reduce the dusting of the belt

### The advantages

- "Easy pass" rollers for a sheeting process without any risk of dough tearing  
- Possibility of sheeting dough billets weighing up to 8 kg, on a 600-mm width belt

- **Ease of use:**
  - "Easy pass" rollers
  - Very straightforward thickness adjustment
  - Stainless steel dough catch pans
  - Double "hand or foot" control that adapts to the user's preferences (base-mounted models)
  - New ergonomic cutting station
  - Antistatic belt which allows to reduce the dusting of the belt

- **Ease of cleaning:**
  - removable flour tank
  - Flour recovery tray (floor type model)
  - Washable belt with a damp sponge

- **Safety features compliant with the EC Standard**
  - 24V control circuit
  - Safety audit

### Use

The Rhea mechanical dough sheeter enables any type of dough to be turned and pinned.

### Operating principle

Before each pass, the user adjusts the thickness setting of the rolled dough by means of a lever that controls the cylinder spacing. This setting is visible on a graduated arc or a digital display available on the 600LC model. The speed difference in the belts positioned at the cylinder inlet and outlet helps ensure a rolling step without any jamming or tearing of the dough. At the end of the operation, the rolled dough is easily recovered thanks to the mobile roller positioned at the end of the belt.

### Construction

- Rolling cylinders in chrome steel, diameter 80 mm for a high level of precision
- Stainless steel base frame coated with food-grade epoxy
- Synthetic belt
- 2 fold-up tables for all models, except for 600LC (1 fold-up table)
- Easy to clean and removable dough scrapers
- 1 aluminium dough band recovery roller
- 2 "Easy pass" rollers

### Table top model:

- Base frame mounted on castors
- Stainless steel removable flour tank
- Dual "hand/foot" controls on floor type models
- Stainless steel dough catch pans

### Cutting station model SLC :

- Fitted with a Cutting station with a tool storage rack fitted with castors
- Variable cutting speed adjustment switch
- Available with a new roller gap digital display

# Rhea Dough sheeters

Models	500 T	500 TL	500	500 L	600	600 L	600 LC with/ without digital display
<b>Main characteristics</b>							
Belt width (mm)	500	500	500	500	600	600	600
Table length (mm)	500	750	750	1000	1000	1400	1400
Type of support	Table top		Floor type				
Driven input and output conveyors	■	■	■	■	■	■	■
Cutting station	❖	❖	❖	❖	❖	❖	■
Variable speed drive	❖	❖	❖	❖	❖	❖	■
<b>Ergonomics</b>							
Fold-up tables for storage (on 1 side, only available for 600LC model)	■	■	■	■	■	■	■
Built-in stationary flour tank	■	■	❖	❖	❖	❖	❖
Removable flour tank	❖	❖	■	■	■	■	■
Stainless steel dough catch pans	■	■	■	■	■	■	■
Dual "hand and foot" controls	❖	❖	■	■	■	■	■
Fitted with an aluminum dough band recovery roller	■	■	■	■	■	■	■
Flour recovery tray	❖	❖	■	■	■	■	■
Storage rack for cutting tools	❖	❖	❖	❖	❖	❖	■
2 "Easy Pass" rollers	■	■	■	■	■	■	■
Digital display of roller spacing	❖	❖	❖	❖	❖	❖	€
<b>Power supply voltage</b>							
THREE-PHASE 400 V 50 Hz	■	■	■	■	■	■	❖
SINGLE-PHASE 230 V 50-60 Hz	❖	❖	❖	❖	❖	❖	■
THREE-PHASE 230 V 50 Hz	□	□	□	□	□	□	❖
THREE-PHASE 208 V 60 Hz	□	□	□	□	□	□	❖
<b>Packaging (including fumigation treatment as a standard feature, compliant with international Standard NIMP 15)</b>							
Pallet with plastic protection film	■	■	■	■	■	■	■
Closed wooden crate	€	€	€	€	€	€	€
Latticed wooden crate	€	€	€	€	€	€	€

<b>Accessories for Rhea 600 LC*</b>						
Designation	Dimensions (mm)		Raw products weights (g)		mini	maxi
	Base	Height				
1st tool: shape cutting	Rhea - 3 rows triangle cutter	130	183	50	80	
	Rhea - 4 rows triangle cutter	110	137	35	45	
	Rhea - 3 rows triangle cutter	200	180	82	112	
	Rhea - 5 rows triangle cutter base	80	110	20	27	
	Rhea - rectangular cross cutter	110	-	50	80	
	Rhea - rectangular cross cutter	130	-	70	100	
	Rhea - 4 round and smoothed cutters	Ø 140	-	65	85	
	Rhea - 5 round and smoothed cutters	Ø 100	-	30	50	
	Rhea - 4 round and ribbed cutters	Ø 140	-	65	85	
	Rhea - 5 round and ribbed cutters	Ø 100	-	30	50	
	Rhea - 5 oval and smoothed cutters	180	90	50	90	
Rhea - 5 oval and ribbed cutters	180	90	50	90		
2nd tool: dough strip cutting	Rhea - strip cutter 6 discs				**	

\* It is necessary to install a dough strip cutter while using triangle or rectangular cross cutters

\*\*the number of discs and the spacing between rows have to be adapted on the required shape

For other shapes, consult us

# Rhea Dough sheeters

Technical features								
Model		500 T	500TL	500	500L	600	600 L	600 LC
Belt width	(mm)	500	500	500	500	600	600	600
Table length	(mm)	500	750	750	1000	1000	1400	1400
Motor power (for 3PH 400 V at 50 Hz)	(kW)	0,55	0,55	0,55	0,55	0,75	0,75	1
Net weight	(kg)	130	140	220	230	240	250	300
Dough roller diameter	(mm)	80						
Roller gap opening	(mm)	1-47						
Minimum - maximum dough billet weight	(kg)	0,5 - 4		0,5 - 6		0,5 - 8		0,5 - 8

Models		500 T	500TL	500	500L	600	600 L	600 LC
A	Belt width	(mm)	500	500	500	500	600	600
B	Total depth	(mm)	865	865	910	910	1010	1010
C	Total width in working position	(mm)	1530	2150	2100	2475	2475	3221
D	Total width in storage position	(mm)	1165	1395	1243	1389	1389	1460
E	Working height	(mm)	215	215	900	900	900	900
F	Total height in working position	(mm)	690	690	1160	1160	1160	1160
G	Total height in storage position	(mm)	985	985	1685	1685	1685	2093

Emballage		Model	500 T	500TL	500	500L	600	600 L	600 LC
<b>Mainland (Cardboard box on pallet)</b>	Width	(mm)	1113	1113	1113	1113	1113	1113	1113
	Lenght	(mm)	1170	1170	1170	1170	1170	1170	1170
	Height	(mm)	840	1100	1300	1700	1300	1740	1840
	Weight	(kg)	150	160	250	250	260	270	320

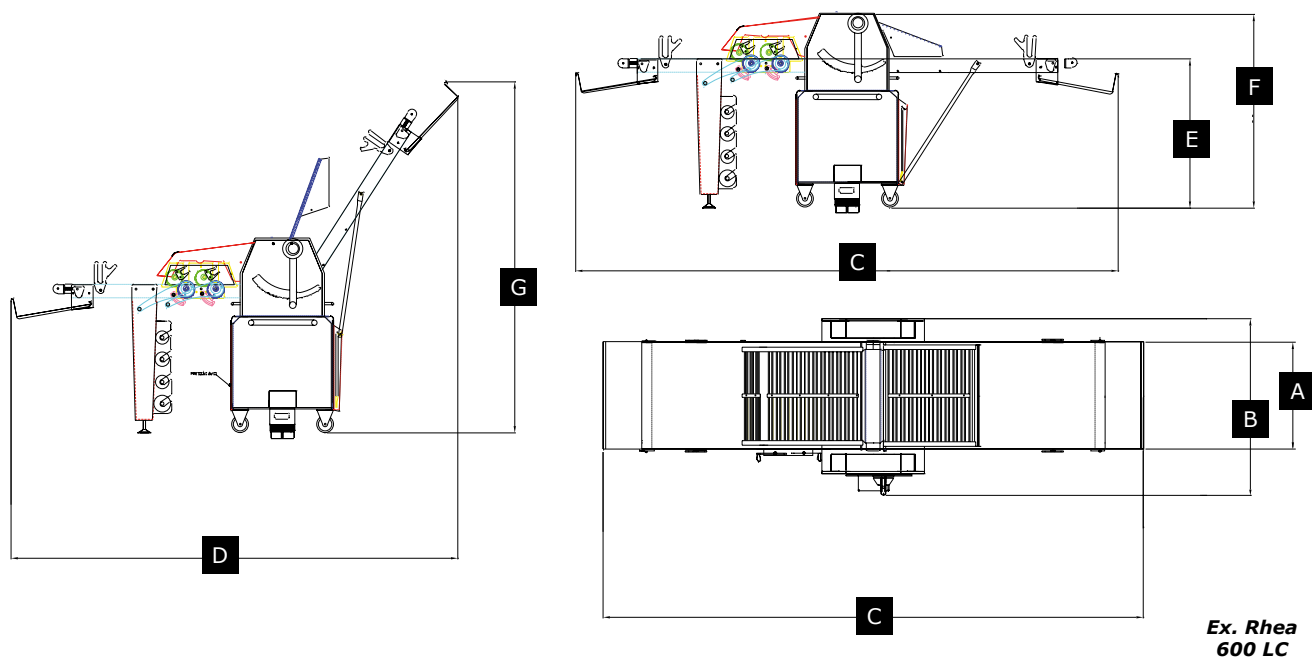

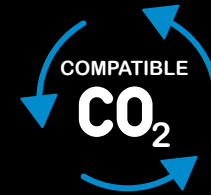

## Reach-In Retarder-proofer for bakery and Danish pastry use

### Performances

- 20 adjustable pairs of tray slides
- Opticom control
- Assembled topside compressor (for an ambient temperature lower than 30°C)
- BFA supplied assembled
- Connecting power: 230 V single PH + Gr, 50 Hz
- Possibility to order on demand remote or silent compressors

### The advantages

- Large range of models
- Cabinet supplied assembled, ready to connect
- Incorporated topside hermetic refrigeration unit
- Easy to move thanks to its 3 wheels and 2 adjustable feet
- Adjustable humidity (30-90%)
- The cabinets are fitted with "Urails" for use either as a pastry or bakery unit
- Easy cleaning
- On site reversibility of doors
- Refrigeration unit ready for use with refrigerating fluid R 448A

### Use

The BFA intermediate proofer is used to slow down and control proofing of dough pieces over a period of time defined by the user.

### Operating principle

The dough pieces are stored in the retarder-proofer (between 2°C and 4°C) to retard proofing (72 hours maximum). Once the control panel has been programmed, the proofer manages the temperature increase on the basis of information previously entered by the user. Electronic regulation supervise stage-by-stage warming (and/or constant temperature increase degree-by-degree). The proofer stabilises the hot cycle temperature and offers at the end of the cycle a «sleeping» function, i.e. repeating the cold cycle if the controller is not activated after 45 minutes following the programmed end of proofing (adjustable values).

### Construction

- Panels injected with polyurethane foam 42 kg/m<sup>3</sup>
- Enclosures: 60 mm isothermal hot electro-plated zinc panels, pre-lacquered, painted and coated with a protective food grade PVC of 120 micron thickness
- Aluminium (frame and blades) and copper (tube) ceiling-fitted evaporator.
- Water connection Ø 12 mm, water drain Ø 32 mm
- 4 vertical mixed "U-rails" designed to receive tray slides:
  - BFA 1C1P available with 73 levels, spacing of 21mm, with a capacity of : 18 trays with a spacing of 84mm or 24 trays with a spacing of 63mm
  - BFA 2C2P available with 2x31 levels, spacing of 21mm, with a capacity of : 2x7 trays with a spacing of 84mm or 2x10 trays with a spacing of 63mm

### ••• Important notes :

- The BFA retarder proofers are supplied without grid and linen canvas (trays not supplied)
- Attention, the intervention of a qualified refrigeration engineer is necessary for all installations of 2 compartments/2 temperatures BFA models shipped disassembled.

### Remarks on refrigeration unit (compressor):

-Remote tropicalised compressor :

Higher power unit designed for installation up to 8 m away from the chamber including the elbows (1 elbow = 1m) and for an operating room temperature up to 43°C.

-Soundless :

Noiseless streamlined unit (at least 7 to 12dB lower than the standard unit) designed for installation up to 8 m away from the chamber including the elbows (1 elbow = 1m) and for an operating room temperature up to 43°C.

-Remote soundless (Silensys):

Noiseless streamlined unit (at least 7 to 12dB lower than the standard unit) designed for installation 8 to 20 m away from the chamber including the elbows (1 elbow = 1m) and for an operating room temperature up to 43°C.

-Delivery without unit:

When the BFC is intended for plant connection. Reminder: Connection must be carried out by a qualified refrigeration engineer.

# Reach-In Retarder-proofer **BFA - 1 compartment - 1 door - 1 temperature**

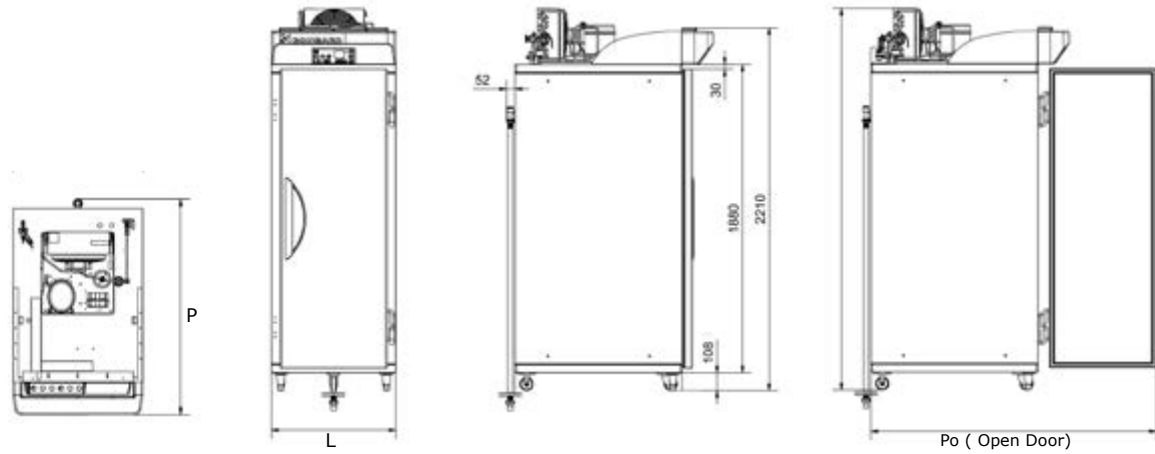

<b>Accessories - Unit</b>	<b>Dimensions W x L x H</b>
Additional tray slide for BFA 400 x 600 model only	30 x 595 x 28
Additional tray slide For any other BFA models	30 x 795 x 28

<b>Features</b>		<b>Dimensions &amp; weight</b>					<b>Energetic features</b>	
<b>Tray size</b>	<b>Width</b>	<b>Depth</b>	<b>Opened door</b>	<b>Height</b>	<b>Net weight</b>	<b>Dough capacity maxi.</b>	<b>Connecting power</b>	<b>Compressor unit</b>
<b>(mm)</b>	<b>(mm)</b>	<b>(mm)</b>	<b>(mm)</b>	<b>(mm)</b>	<b>(kg)</b>	<b>(kg)</b>	<b>(kW)</b>	
<b>1 compartment / 1 door / 1 temperature</b>								
400 x 600	560	1065	1343	2290	130	29	0.9	Standard tropicalized - assembled
	560	1065	1343	2210	130	29	0.9	Tropicalized - disassembled / remoted
400 x 800	620	1265	1603	2290	176	35	0.9	Standard tropicalized - assembled
	620	1265	1603	2210	176	35	0.9	Tropicalized - disassembled / remoted
460 x 800	620	1265	1603	2290	176	43	0.9	Standard tropicalized - assembled
	620	1265	1603	2210	176	43	0.9	Tropicalized - disassembled / remoted
600 x 800	760	1265	1743	2330	232	60	1.3	Standard tropicalized - assembled
	760	1265	1743	2210	232	60	1.3	Tropicalized - disassembled / remoted

••• Notes :

- \* BFA without humidity, only for Danish pastries. Supplied without water solenoid valve, without hygrostat, without nozzle
- \*\* BFA shipped disassembled

## Reach-In Retarder-proofer **BFA - 1 compartment - 2 doors - 1 temperature**

<b>Accessories - Unit</b>	<b>Dimensions W x L x H</b>
Additional tray slide for BFA 400 x 600 model only	30 x 595 x 28
Additional tray slide For any other BFA models	30 x 795 x 28

<b>Features</b>		<b>Dimensions &amp; weight</b>					<b>Energetic features</b>	
<b>Tray size</b>	<b>Width</b>	<b>Depth</b>	<b>Opened door</b>	<b>Height</b>	<b>Net weight</b>	<b>Dough capacity maxi.</b>	<b>Connecting power</b>	<b>Compressor unit</b>
<b>(mm)</b>	<b>(mm)</b>	<b>(mm)</b>	<b>(mm)</b>	<b>(mm)</b>	<b>(kg)</b>	<b>(kg)</b>	<b>(kW)</b>	
<b>1 compartment / 2 doors / 1 temperature</b>								
700 x 800	965	1265	1549	2385	260	63	1.3	Standard tropicalized - assembled
	965	1265	1549	2210	260	63	1.3	Tropicalized - disassembled / remoted
765 x 800	965	1265	1549	2385	260	69	1.3	Standard tropicalized - assembled
	965	1265	1549	2210	260	69	1.3	Tropicalized - disassembled / remoted
815 x 800	965	1265	1549	2385	260	77	1.3	Standard tropicalized - assembled
	965	1265	1549	2210	260	77	1.3	Tropicalized - disassembled / remoted
915 x 800	1275	1265	1704	2435	274	99	1.9	Standard tropicalized - assembled
	1275	1265	1704	2210	274	99	1.9	Tropicalized - disassembled / remoted
1015 x 800	1275	1265	1704	2435	274	99	1.9	Standard tropicalized - assembled
	1275	1265	1704	2210	274	99	1.9	Tropicalized - disassembled / remoted
1115 x 800	1275	1265	1704	2435	274	120	1.9	Standard tropicalized - assembled
	1275	1265	1704	2210	274	120	1.9	Tropicalized - disassembled / remoted

# Reach-In Retarder-proofer **BFA - 2 compartments - 2 doors - 2 temperatures**

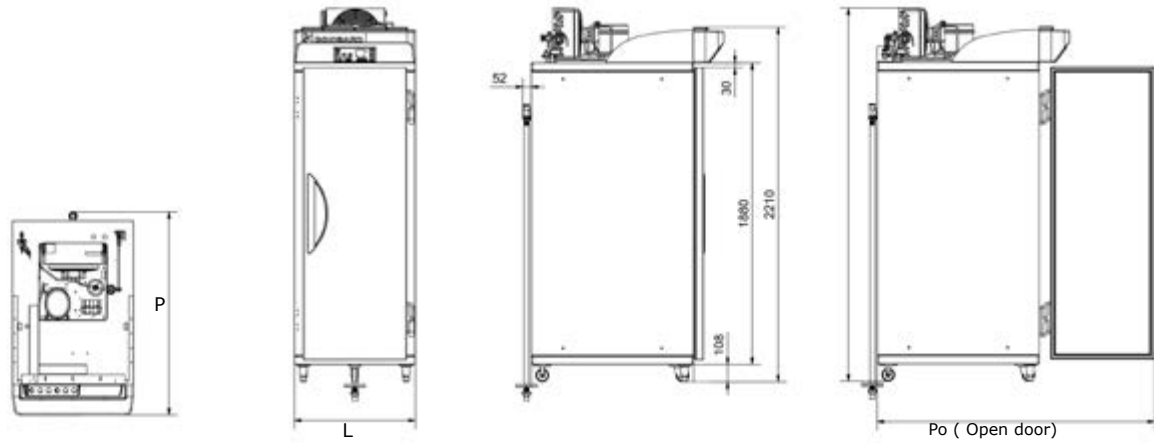

<b>Accessories - Unit</b>	<b>Dimensions W x L x H</b>
Additional tray slide for BFA 400 x 600 model only	30 x 595 x 28
Additional tray slide For any other BFA models	30 x 795 x 28

<b>Features</b>		<b>Dimensions &amp; weight</b>				<b>Energetic features</b>		
<b>Tray size</b>	<b>Width</b>	<b>Depth</b>	<b>Opened door</b>	<b>Height</b>	<b>Net weight</b>	<b>Dough capacity maxi.</b>	<b>Connecting power</b>	<b>Compressor unit</b>
<b>(mm)</b>	<b>(mm)</b>	<b>(mm)</b>	<b>(mm)</b>	<b>(mm)</b>	<b>(kg)</b>	<b>(kg)</b>	<b>(kW)</b>	
<b>2 compartments / 2 doors / 2 temperatures</b>								
400 x 600	560	1065	1343	2290	170	24	1.9	Standard tropicalized - assembled
	560	1065	1343	2210	170	24	1.9	Tropicalized - disassembled / remoted
600 x 800	760	1265	1743	2330	270	51	1.9	Standard tropicalized - assembled
	760	1265	1743	2210	270	51	1.9	Tropicalized - disassembled / remoted

# BFA Paneo



## Dough-Retarder

### Performances

#### **BFA Paneotrad**

- 14 levels (28 tray slides)
- 28 storage tubs of 75 mm or 24 storage tubs of 95 mm (on 12 levels)

#### **BFA dual mode**

- 20 levels (40 tray slides) for baking trays
- 28 storage tubs of 75 mm or 24 storage tubs of 95 mm (on 12 levels)

### The advantages

- Reinforced refrigeration unit
- Temperature regulator
- Forced refrigeration timer
- Automatic defrosting
- Incorporated topside hermetic refrigeration unit
- Easy to move thanks to its 3 wheels and 2 adjustable feet
- The cabinets are fitted with "U-rails" for use either as a pastry or bakery unit
- On site reversibility of doors
- Refrigeration unit ready for use with refrigerating fluid R 448A

### Use

The BFA Paneotrad dough retarder is used to rapidly cool and stabilise dough at +2°C.

### Operating principle

The dough containers are stored in the dough retarder (between 2°C and 4°C) to retard proofing (72 hours maximum). The cycle is run by override with a timer. The temperature of the appliance then returns to a lower point than the set point. Once the containers with the product have been inserted, the BFA stabilises the temperature at +2°C through automatic electrical defrosting at regular intervals.

### **BFA - Paneotrad**

- Refrigerated cabinet only for Paneotrad storage tubs (2 models: 75 mm - 95 mm).

### **BFA - dual mode**

- Paneotrad functions identical to the BFA - Paneotrad
- Proofing functions identical to the standard BFA retarder-proofer
- Positive temperature refrigeration with electrical defrosting and more powerful refrigeration compressor

### Construction

- Cabinet : 60 mm isothermal hot electro-plated zinc panels, pre-lacquered, painted and coated with a protective food grade PVC of 120 micron thick
- Panels are injected with polyurethane foam 42 kg/m<sup>3</sup>
- Aluminium (frame and fins) and copper (tube) ceiling-fitted evaporator
- Water connection Ø 12 mm, water drain Ø 32 mm

### Remarks on refrigeration unit (compressor):

-Remote tropicalised compressor :

Higher power unit designed for installation up to 8 m away from the chamber including the elbows (1 elbow = 1m) and for an operating room temperature up to 43°C.

-Soundless :

Noiseless streamlined unit (at least 7 to 12dB lower than the standard unit) designed for installation up to 8 m away from the chamber including the elbows (1 elbow = 1m) and for an operating room temperature up to 43°C.

-Remote soundless (Silensys):

Noiseless streamlined unit (at least 7 to 12dB lower than the standard unit) designed for installation 8 to 20 m away from the chamber including the elbows (1 elbow = 1m) and for an operating room temperature up to 43°C.

-Delivery without unit:

When the BFC is intended for plant connection. Reminder: Connection must be carried out by a qualified refrigeration engineer.



# Dough retarder **BFA Paneotrad - 1 compartment - 1 door - 1 temperature**

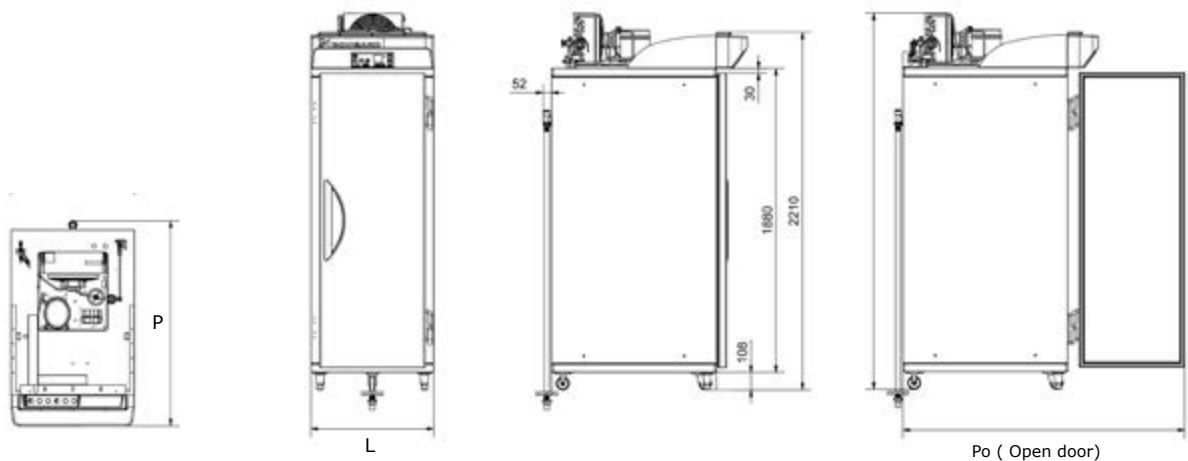

General features		Dimensions and weight				Energetic features		
Control	W (mm)	D (mm)	Po (mm)	H (mm)	Weight (kg)	Dough capacity maxi. (kg)	Connecting power (kW)	compressor unit
<b>BFA Paneo 600 x 800</b>								
EM	760	1265	1743	2328	232	28 storage tub (75 mm) 24 storage tub (95 mm)	1.3	Standard assembled
EM	760	1265	1743	2328	232		1.3	Disassembled
EM	760	1265	1743	2328	232		1.3	Remote
EM	760	1265	1743	2328	232		1.3	Tropicalized disassembled
EM	760	1265	1743	2328	232		1.3	Tropicalized assembled
EM	760	1265	1743	2328	232		1.3	Standard assembled
<b>BFA Mixte 600 x 800</b>								
Opticom	760	1265	1743	2328	232	28 storage tub (75mm) 24 storage tub (95mm) or 60 kg dough on baking trays	1.3	Standard assembled
Opticom	760	1265	1743	2328	232		1.3	Disassembled
Opticom	760	1265	1743	2328	232		1.3	Remote
Opticom	760	1265	1743	2328	232		1.3	Tropicalized disassembled
Opticom	760	1265	1743	2328	232		1.3	Tropicalized assembled
Opticom	760	1265	1743	2328	232		1.3	Standard assembled



## Single compartment—compact Roll-In Retarder-proofer

### Performances

- 5 models available for the following tray sizes:
  - 400 X 600
  - 400 X 800
  - 460 X 800
  - 600 X 800 (or 2 racks 600 X 400)
  - 1000 X 800 (or 2 racks 460 X 800 )
- Note that BFM's are delivered without any rack
- Water connection Ø 12 mm, water drain Ø 32 mm

### The advantages

- "Plug and play": cabinet supplied assembled, ready to connect
- Incorporated topside hermetic refrigeration unit
- 5 standard models available
- Retarding, slow fermentation or traditional fermentation
- Adjustable humidity (30-90%)
- Cataphoresis coated evaporator for an excellent corrosion resistance
- Easy cleaning
- On site reversibility of doors
- Refrigeration unit ready for use with refrigerating fluid R 448A

### Use

The BFM retarder proofer is used to slow down and control proofing of dough pieces over a period of time defined by the user.

### Operating principle

The dough pieces are stored in the retarder-proofer (between 2°C and 4°C) to retard proofing (72 hours maximum). Once the control panel has been programmed, the proofer manages the temperature increase on the basis of information previously entered by the user. An electronic regulation supervises stage-by-stage warming (and/or constant temperature increase degree-by-degree). The proofer stabilises the proofing cycle temperature and offers at the end of the cycle a «sleeping» function, i.e. repeating the cold cycle if the controller is not activated after 45 minutes following the programmed end of proofing (adjustable values).

### Construction

#### • Panels

- 60 mm thick isothermal panels.
- injected with polyurethane foam, of a density of 42 kg/m<sup>3</sup>
- sheet metal coating, inside/outside galvanized steel of 6/10 thickness, coated with a protective food grade PVC of 120 micron thick
- protected against impacts with inner stainless steel (304) rails of 1.5 mm thickness

#### • Doors

- plain doors, same material as panels with single door for BFM 400 X 600, 400X 800, 460 X800 , 600X 800 and double door for BFM 1000 X 800

#### • Technical units

- evaporator with e-coating (Cataphoresis) treatment (for leavened bread, sourdough, slow fermentation)
- Standard assembled: standard compressor on the top of the retarder-proofer suitable with an ambient temperature of below 30°C

### Remarks on refrigeration unit (compressor):

- Remote tropicalised compressor :  
Higher power unit designed for installation up to 8 m away from the chamber including the elbows (1 elbow = 1m) and for an operating room temperature up to 43°C.
- Soundless :  
Noiseless streamlined unit (at least 7 to 12dB lower than the standard unit) designed for installation up to 8 m away from the chamber including the elbows (1 elbow = 1m) and for an operating room temperature up to 43°C.
- Remote soundless (Silensys):  
Noiseless streamlined unit (at least 7 to 12dB lower than the standard unit) designed for installation 8 to 20 m away from the chamber including the elbows (1 elbow = 1m) and for an operating room temperature up to 43°C.
- Delivery without unit:  
When the BFC is intended for plant connection. Reminder: Connection must be carried out by a qualified refrigeration engineer.

# Roll-In Retarder-proofer **BFM**

Models	400 X 600	400 X 800	460 X 800	600 X 800	1000 X 800
<b>Use</b>					
Bakery use	■	■	■	■	■
Dual mode (Bakery use + Paneotrad)	€	€	€	€	€
Additional heating and second water nozzle	-	-	€	€	€
<b>Control type</b>					
Opticom control	■	■	■	■	■
Electromechanical control (Bakery use only)	□	□	□	□	□
<b>Door</b>					
Left door handle side	■	■	■	■	-
Right door handle side	□	□	□	□	-
Double door leaf	-	-	-	-	■
<b>Construction</b>					
PVC film finish - interior and exterior	■	■	■	■	-
Stainless steel interior, PVC film exterior	€	€	€	€	€
Stainless steel interior and exterior	€	€	€	€	€
Inner stainless steel protection rails	■	■	■	■	■
Electromechanical hygrostat	■	■	■	■	■
Non-skid insulated floor and access ramp	€	€	€	€	€
<b>Condensing unit (*)</b>					
Tropicalized assembled	■	■	■	■	■
Remote tropicalized below 8 m	□	□	□	□	□
Remote tropicalized from 8 to 20 m	€	€	€	€	€
Silent tropicalized ( 220-240V/50Hz only)	€	€	€	€	€
<b>Assembly</b>					
Assembled*	■	■	■	■	-
Disassembled**	€	€	€	€	■

Technical features						
Model		400 X 600	400 X 800	460 X 800	600 X 800	1000 X 800
<b>Connecting power</b>						
Bakery and dual mode use	(kW)	1	1	1	1,5	2
<b>Compressor power</b>						
Bakery use	(CV)	3/8	1/2	1/2	5/8	1
Dual mode use	(CV)	1/2	5/8	5/8	1	1 1/8
<b>Maximum dough capacity</b>						
bakery use	(kg)	32	45	52	84	109
«blocking cold dough « use	(kg)	70	95	109	143	210
<b>Amperage in 220V-240V single phase</b>						
Bakery use and dual mode use	(A)	5	5	5	6	9
<b>Power supply</b>						
Standard		220-220V / ~1PH+N+T / 50 Hz				
<b>Frigorific power (-10°C / +32°C )</b>						
Bakery use	(kW)	0,74	0,88	0,88	1,29	1,57
Dual mode use	(kW)	0,88	1,29	1,29	1,29	1,57

■ Standard | □ Option | - N/a

# Roll-In Retarder-proofer **BFM**

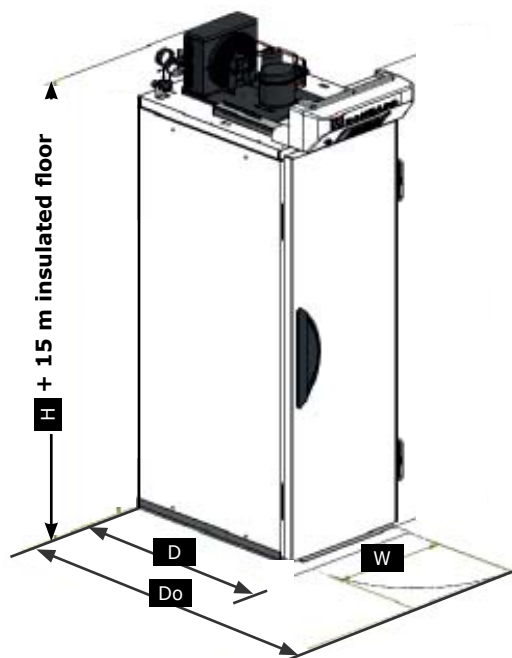

**Useful interior dimensions**

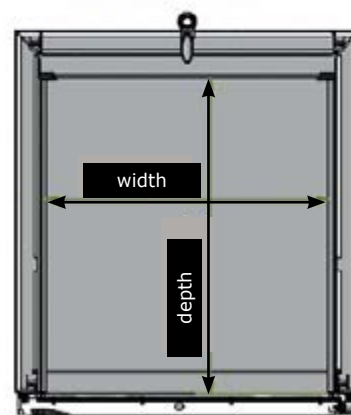

Important : water connection required

Dimensions (without insulated floor, assembled compressor)											
Model Tray size	Entry direction of rack	External dimensions					Useful internal dimensions		Free Space Between panels (mm)	Maximum height of rack	Door type
		W	D	Do - door opened	H*		Width	Depth			
					bakery use-Tropicalized compressor	dual use-Tropicalized compressor					
(mm)	(mm)	(mm)	(mm)	(mm)	(mm)	(mm)	(mm)				
400 x 600	400	670	890	1505	2400	2400	490	690	530	1855	single
400 x 800	400	670	1090	1705	2400	2400	490	890	530	1855	single
460 x 800	460	770	1090	1805	2400	2400	590	890	630	1855	single
600 x 800	600	975	1090	2010	2400	2452	795	890	835	1855	single
1000 x 800	1000	1285	1090	1720	2452	2505	1105	890	1145	1855	dual

(\*) Option insulated floor involves an additional height (H) of 15 mm  
 (\*\*) The total height (H) is 2285 if the condensing unit is not installed (top side)

Specification of racks suitable with BFM					
Models Tray size (mm)	Number of rack	Maximum dimension of racks			
		Height	Width	Depth	
		(mm)			
400 x 600	1	1855	480	650	
400 x 800	1	1855	480	850	
460 x 800	1	1855	580	850	
600 x 800	1	1855	785	850	
600 x 400	2				
1000 x 800	1	1855	1080	850	
460 x 800	2				

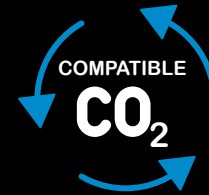

## Roll-In Retarder-proofer

### Performances

- Fermentation chamber for racks 400/460 x 800, 800 x 600, 700 x 900, 750 x 900 depending on model up to 1215 x 800 mm. BFC's are supplied without any rack.
- Cells are defined by their internal width (800, 1000, 1200, etc...) they can be installed side by side
- Door handle on the left unless otherwise specified

### The advantages

- Custom made product
- Electronic regulation
- Electromechanical hygostat
- Management of the forgotten dough ("sleeping" function)
- Warming-up stages and / or constant increase of the temperature (degree per degree)
- Retarding, slow fermentation or traditional fermentation
- E-coated evaporator for an excellent corrosion resistance
- Refrigeration unit ready for use with refrigerating fluid R. 448A

### Use

The BFC roll-in retarder-proofer is used to slow down and control proofing of dough pieces over a period of time defined by the user.

### Operating principle

The dough pieces are stored in the retarder-proofer (between 2°C and 4°C) to retard proofing (72 hours maximum). Once the control panel has been programmed, the proofer manages the temperature increase on the basis of information previously entered by the user. Electronic regulation supervise stage-by-stage warming (and/or constant temperature increase degree-by-degree). The proofer stabilises the hot cycle temperature and offers at the end of the cycle a «sleeping» function, i.e. repeating the cold cycle if the controller is not activated after 45 minutes following the programmed end of proofing (adjustable values).

### Construction

#### Panels

- 60 mm thick isothermal panels.
- injected with polyurethane foam, of a density of 42 kg / m<sup>3</sup>
- sheet metal coating, inside/outside aluminium of 8/10 thickness, coated with a protective food grade PVC of 120 micron thick
- protected against impacts with inner stainless steel (304) rails of 1.5 mm thick

#### Doors

- plain doors, same material as panels with single or/and double door
- built-in with an insert in order to protect the joint and optimize the isolation
- outside rails to avoid possible impacts from racks

#### Technical units

- evaporator with e-coating (Cataphoris) treatment (for leavened bread, acid dough, slow fermentation)
- air cooled refrigeration unit (compressor) foreseen for an installation up to 8 m maximum including the elbows (1 elbow = 1 m). Installation of compressor during the assembly
- remote refrigeration unit or tropicalised unit or silent unit
- connecting power : 400 V (3 PH + N + Gr) 50 Hz

#### Assembly

- constituted by modular panels assembled by eccentric hooks
- wall panels fitted into a base frame made of PVC of 30 mm height fixed to the floor
- inside lighting

## Roll-In retarder-proofer **BFC**

<b>BFC</b>	
<b>Evaporator kit</b>	
Standard version	■
Paneo version	€
Mixed version	€
Hot + version	€
<b>Control</b>	
OPTICOM	■
Electromechanical	□
<b>Hygrometry sensor</b>	
HG mini	■
Electronic (Only with OPTICOM)	€
<b>Finish on panels and doors</b>	
Inside and outside in PVC-coated aluminum	■
Inside stainless steel/Outside in PVC-coated steel	€
Inside and outside stainless steel	€
Stainless steel front	€
External aluminium protection on the panels	€
<b>Refrigerating unit</b>	
Standard	■
Remote unit	€
Tropicalised	€
Tropicalised remote unit	€
Silensys	€
Silensys remote unit	€
Delivered without the unit	□
<b>Miscellaneous</b>	
Insulating floor and stainless steel ramp	€
Insulating stainless steel floor and stainless steel ramp	€
T° reminder	€
Tunnel	€
Extra lighting	€

### Technical modules 800 or 1000 made of stainless steel 304

The functions :  
Ventilation, Cooling, Heating, Humidifying are all collected in a technical module

### Control panel

Placed above the door, it contains the necessary controls for the rational use and the functioning of the chamber. An electrical power supply is necessary per compartment.

<b>Technical unit features</b>			
<b>Technical unit</b>		<b>800</b>	<b>1000</b>
<b>Ventilation fans</b>			
Quantity	0	1	3
Heater	(kW)	2	2.5
Number of spraying nozzles	depending on model	1 - 2	1 - 2
Safety thermostat	(°C)	55	55
<b>Dimensions</b>			
Height	(mm)	1970	1970
Overall width	(mm)	770	970
Depth	(mm)	110	110
<b>Connect./ Freon refrigeration gas pipe Ø</b>			
Inlet	( < )	3/8	3/9
Outlet	( < )	5/8	5/9

# Roll-In retarder-proofer BFC

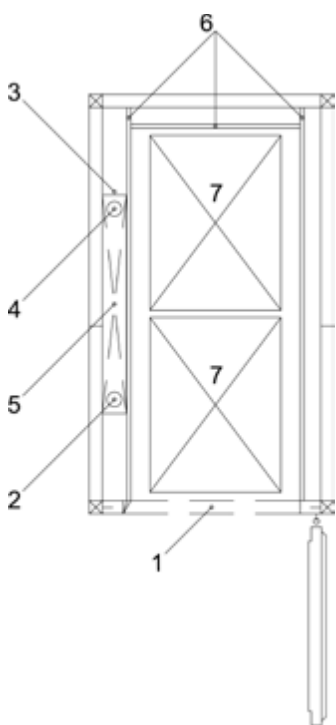
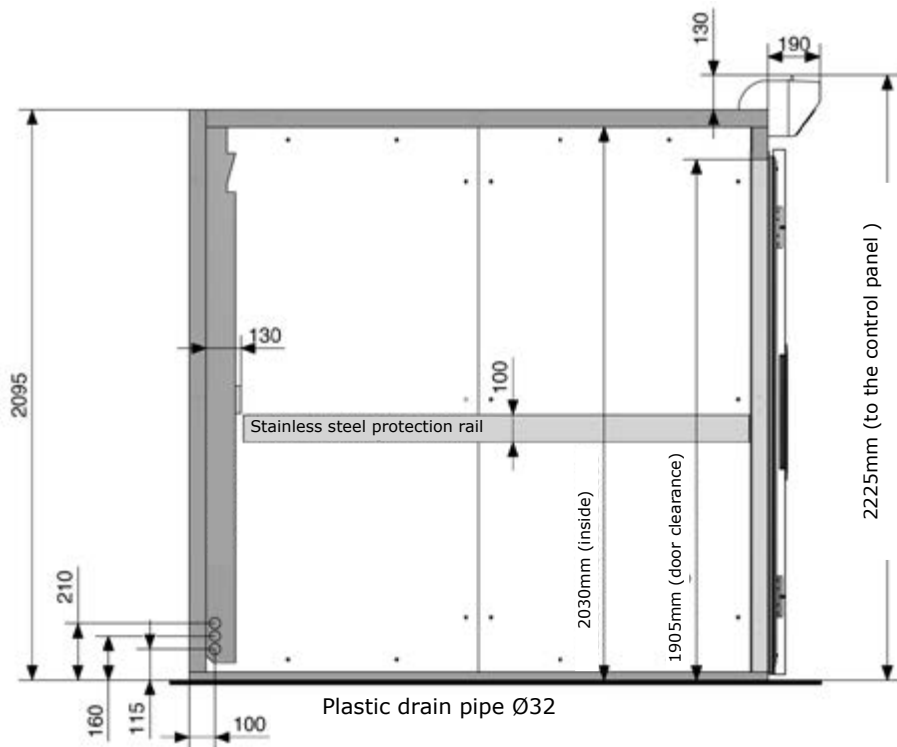

- 1 Electric Supply 400 V 3 ph + N + Gr 50 HZ
- 2 Water supply in copper pipe Ø 12 - 2,2 m from the floor, only 1 water supply is necessary for a maximum of 3 cells
- 3 PVC water drain pipe Ø 32 from 0 to 0,2 m from the floor
- 4 Freon gas pipe (Ø depends on the compressor)
- 5 Technical module
- 6 Protection rails
- 7 Racks

<b>General features</b>		
Minimum requested ceiling height (topside compressor)	(mm)	2800
Minimum requested ceiling height (with remote compressor)	(mm)	2250
Useful door clearance (total)	(mm)	1905
<b>The depth and the length of compartment can be increased at will by module of 200 mm</b>		



## Roll-In Final proofer

### Performances

- Fermentation chamber for racks 400/460x800, 600x800, 700x900, 750 x 900 depending on model up to 800 x 1000 mm
- Cells are defined by their internal width (800, 1000, 1200, etc...) they can be installed side by side
- Door handle on the left unless otherwise specified

### The advantages

- Custom made product
- Easy to assemble panels by means of excentric hooks
- Electromechanical regulation
- Electromechanical hygrostat
- Maximum proofing temperature : 30°C –38°C

### Use

The BFE proofer is used to reach a set temperature (30°C-38°C) very rapidly. It is used for fast proofing of baking and pastry products.

### Operating principle

A technical unit (ventilation, heat production and humidity production) placed inside the enclosure warms the air to a set temperature defined by the user (30°C-38°C). An electromechanical hygrostat regulates the humidity rate from 30% to 90%. Ventilators maintain an even temperature and humidity at all times throughout the proofer.

### Construction

- 60 mm thick isothermal Panels.
- Made of modular panels assembled by eccentric hooks
- The panels are injected with polyurethane foam, of a density of 40 kg / m<sup>3</sup>
- Sheet metal coating, inside aluminium of 8/10 thickness pre-lacquered, painted and coated with a protective polyethylene covering
- Plain doors (same material as panels with single or/and double door)
- The wall panels are fitted into a base frame made of PVC of 30 mm height fixed to the floor
- Inside lighting
- Connecting power : 400 V (3 PH + N + Gr) 50 Hz

### Options

- Electronic pin type humidity sensor (only with electronic regulation Opticom)
- Insulated floor with stainless steel ramp
- Stainless steel interior and isothermal hot electro-plated zinc exterior panels, pre-lacquered, painted and coated with a protective polyethylene covering
- Stainless steel (5/10 thick) interior and exterior

### • • • Important notes :

BFE's are supplied without rack.



# Roll-In final proofer **BFE**

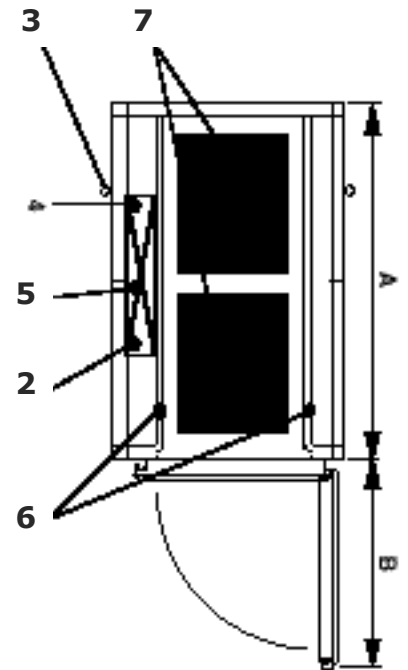
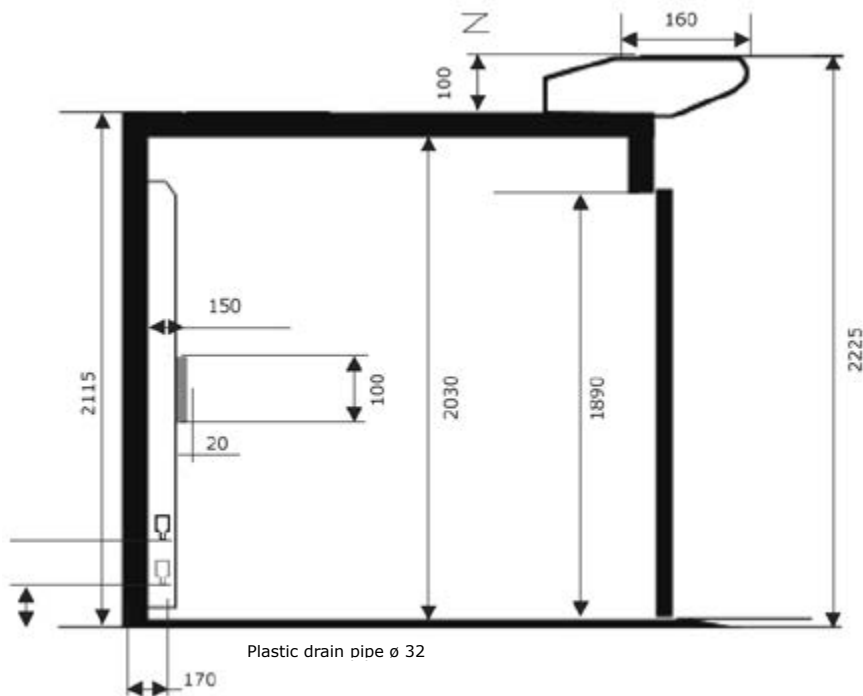

- 1 Electric Supply 400 V 3 ph + N + Gr 50 HZ
- 2 Water supply in copper pipe  $\varnothing$  12 - 2,2 m from the floor, only 1 water supply is necessary for a maximum of cells
- 3 PVC water drain pipe  $\varnothing$  32 from 0 to 0,2 m from the floor
- 5 Technical unit
- 6 Guides
- 7 Racks

<b>General features</b>		
<b>Height</b>		
Front	(mm)	2200
compartment	(mm)	2090
Minimum requested ceiling height	(mm)	2250
Useful door clearance	(mm)	1890
<b>The depth and the length of compartment can be increased at will by module of 200 mm</b>		

<b>Features of the technical unit</b>			
<b>Technical unit</b>		<b>800</b>	<b>1000</b>
<b>Ventilation fans</b>			
Quantity		2	3
Heater	(kW)	2	2.5
Number of spraying nozzles		1	1
Safety thermostat	(°C)	55	55
<b>Dimensions</b>			
Height	(mm)	2200	2200
Overall width	(mm)	840	1040
Depth	(mm)	170	170

**Technical module 800 or 1000 made of stainless steel**

#### **The functions :**

- Ventilation
  - Heating
  - Humidifying
- Are all collected in a technical module

#### **Control panel**

- Placed above the door, it contains the necessary controls for the rational use and the functioning of the chamber
- An electrical power supply is necessary per compartment



## Reach-In Blast freezer

### Performances

- BSP 46.5 : 5 trays 400 x 600 mm
- BSP 46.9 : 9 trays 400 x 600 mm
- BSP 46.15 : 15 trays 400 x 600 mm
- Electromechanical control panel
- Opticom control panel (option)
- Door handle side on the left

### The advantages

- 3 models
- Fast freezing mode
- "special cold" ventilation fan
- Stainless steel interior panels for an easy cleaning
- Right or left door handle side
- Easy to move
- Easy to remove single-piece tray slide rack
- Refrigerating fluid R 452A which preserves the ozone layer

### Use

The blast freezing BSP is designed to blast chill and blast freeze the product before conservation mode.

### Operating principle

With its electromechanical control which autonomously controls the temperature and time needed to freeze products, the BSP is capable of controlling cold production to reach  $-18^{\circ}\text{C}$  at core, as rapidly as possible (7 kg to 20 kg of raw baguettes per hour, depending on the model). Once this temperature has been reached, it regulates it for 24 hours and automatically switches to storage mode at the end of cycle.

### BSP features :

- Ventilation stops at door opening
- Connecting power 230 V.
- Manual defrosting through ventilation with door open
- Blast freezing or blast chilling with pin type sensor or timer
- Buzzer at the end of cycle (timer)

### Construction

- Built-in compressor
- Refrigerating fluid R 452A which preserves the ozone layer
- Isothermal panel (80 mm thick) made of injected polyurethane foam 42 Kg/m<sup>3</sup>
- Stainless steel interior panels, pre-lacquered, painted and coated with a protective polyethylene covering on the outside
- Sheet panels of evaporators in stainless steel
- Panels assembled by eccentric hooks
- Spacing of 75 mm
- Doors equipped with magnetic gasket with closing feature by spring pivot, easy to remove without tools
- Easy accessible heated seals around doors

### • • • Important notes :

- The drainage is located at the rear of cabinet.
- The blast freezer must be placed in a ventilated area and within a positive room temperature (between  $+13^{\circ}\text{C}$  to  $+30^{\circ}\text{C}$ )

# reach-In blast freezer **BSP**

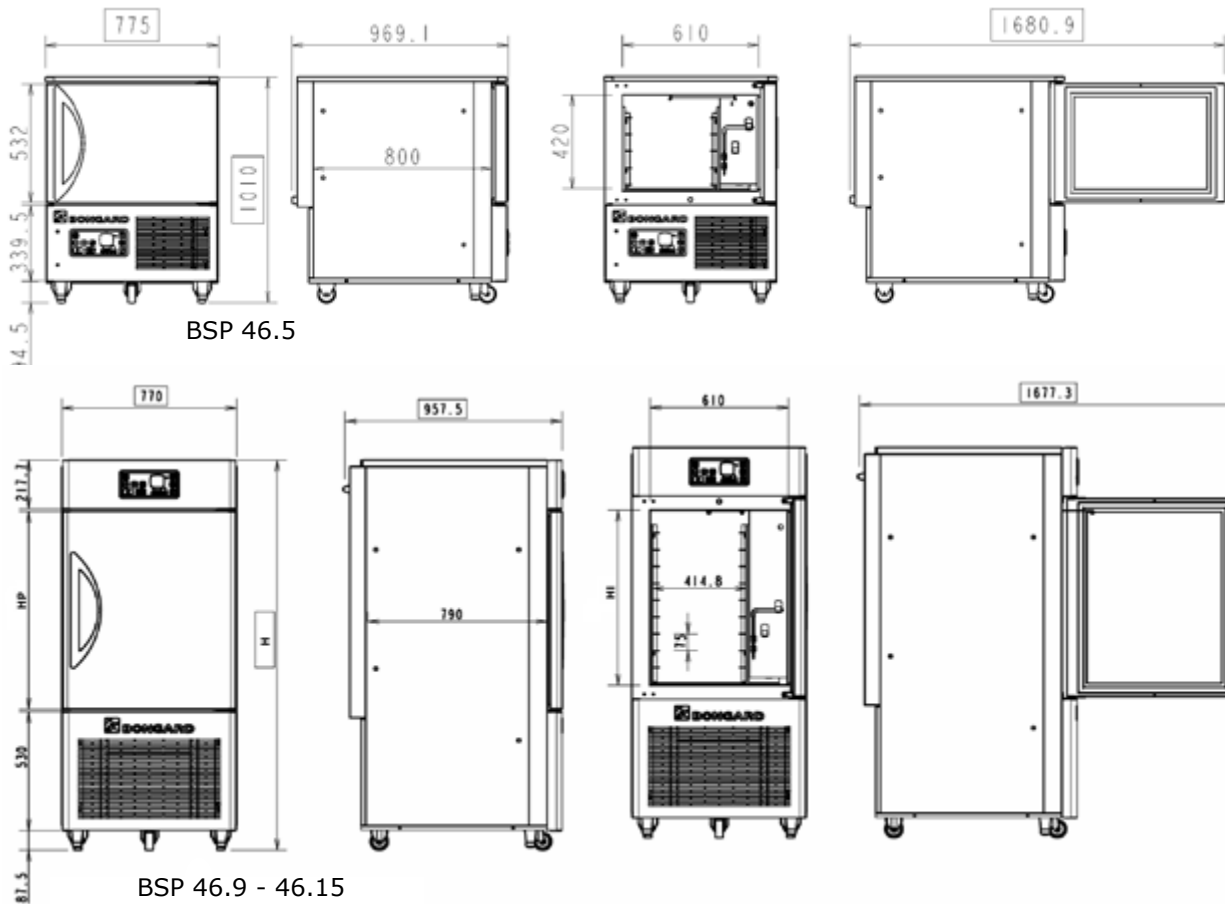

Attention: For a good ventilation of the compressor, the BSP must be placed at a minimum distance of 30 mm from the wall.  
Maximum ambient temperature for compressor: 30°C maxi

<b>General features</b>				
<b>Model</b>		<b>BSP 46.5</b>	<b>BSP 46.9</b>	<b>BSP 46.15</b>
<b>Height</b>				
Front (H)	(mm)	1010	1740	2140
Door height (HP)	(mm)	562	882	1282
Interior height (HI)	(mm)	420	780	1180
<b>Width</b>				
Front	(mm)	775	770	770
Inside	(mm)	610	610	610
<b>Depth</b>				
Inside	(mm)	800	790	790
Outside	(mm)	969	960	960
Door opened	(mm)	1680	1680	1680
Weight	(kg)	110	190	230
Maximal capacity of trays				
400 x 600		5	9	15
<b>Freezing Power in Kg of product</b>				
+22°C / -18°C	(kg/h)	7	13	20

<b>Energetic features</b>				
<b>Model</b>		<b>BSP 46.5</b>	<b>BSP 46.9</b>	<b>BSP 46.15</b>
<b>Power</b>				
Hermetic compressor	(kW)	1.7	1.7	2.15
Heating gasket	(kW)	0.3	0.4	0.7
Fan(s)	(kW)	1 x 0.125	2 x 0.125	3 x 0.125
Total	(kW)	2.23	2.35	3.23
<b>Frigorific power of compressor</b>				
-30 / +30 °C	(kW)	0.48	1.1	2.15
Connecting supply		230 V Single PH+N+Gr, 50 Hz		

<b>Model</b>		<b>BSP 46.5</b>	<b>BSP 46.9</b>	<b>BSP 46.15</b>
Refrigerating fluid:		R452A	R452A	R452A
Global Warming Potential	(GWP)	3922	3922	3922
Freezing program :		SE	SE	SE
Fast freezing program:		RE	RE	RE
Ambiance class (30°C / 55%)		4	4	4
<b>fast cooling program - RE : + 65°C -&gt; + 10°C</b>				
Full-load capacity in freezing	(kg)	16,0	38,0	65,0
duration of freezing cycle + 65°C / +10°C	(min)	120,0	120,0	120,0
Freezing power connexion	(kWh / kg)	0,1	0,1	0,1
<b>Blast freezing program - SE : + 65°C -&gt; - 18°C</b>				
Full load capacity of blast freezing	(kg)	5,5	16,3	26,5
Duration of freezing cycle + 65°C à -18°C	(min)	270,0	270,0	270,0
Energetic consumption of blast freezing	(kWh / kg)	0,7	0,4	0,4
Load of refrigerant	(kg)	0,9	1,4	2,3



## Range of Reach-in combined Blast freezer

### Characteristics

- 1 blast freezer door and 3 (KRYO 31) to 7 (KRYO 71) conservation doors
- Blast freezer with 9 400x600 mm trays, 75 mm spacing, adjustable with a 25 mm pitch
- Conservation unit for 28 to 148 400x600 mm trays, 75 mm spacing, adjustable with a 37.5 mm pitch
- Electronic capacitive touch interface
- Pin type sensor for the blast freezer (as standard)

### The advantages

- Blast-freeze and conservation
- Saving space
- Time saving
- 2 independent cells with 2 units and 2 fully-autonomous controls
- Fault management (refrigeration unit, sensor, open door, defrosting)
- Automatic door opening detector
- Turbine stop when doors opened
- Panels assembled using excentric hooks
- KRYO can be expanded up to 7 doors
- Removable stainless steel hook racks and tray slides
- Refrigeration installation (R 452A)

### Use

The KRYO tray-type blast freezer-conservation unit is designed for cooling and blast freezing of products before conservation.

### Operating principle

With a single piece of equipment, the user can cool, blast freeze and conserve products. Once the target temperature has been reached, KRYO regulates it for 24 hours and then automatically switches over to storage mode at the end of the cycle. The trays are then simply moved from the blast freezer to the storage compartment.

### KRYO special features

#### Blast freezer

- Special "super-cold" turbine
- Manual defrosting through ventilation with door open
- Blast freezing and cooling program in chrono or insertion probe mode
- Acoustic signal at end of cycle
- Alternate display of time and temperature measured by pin type sensor
- Automatic switching to conservation mode at end of freezing or cooling cycle (max 24h)
- Doors not reversible on the blast freezer unit

#### Conservation unit

- Adjustable automatic defrosting by means of resistance and/or manual defrosting
- Evaporator enabling an increase in the conservation unit's storage capacity by adding modules. Unit replacement required depending on the models
- Doors on the conservation unit are reversible

### Construction

- Enclosure: isothermal panels 80 mm thick, injected with 42 kg/m<sup>3</sup> expanded polyurethane foam for the doors and panels, 90 mm for the floor
- Panels on the inside of the unit are covered with stainless steel sheeting, and with electro-galvanised hot-dipped sheet metal covered with a protective food-grade "PET" film on the outside.
- Sheet panels of the conservation-blast freezer evaporator in stainless steel
- Trim panel on upper part of equipment
- Doors equipped with magnetic seal and spring pivot door return system, easy to remove without tools
- Easily accessible heating cords around doors
- Safety hatch on blast freezer side to allow product temperature to be maintained for 24 hours, in case of conservation unit malfunction
- Feet adjustable from 150 to 200 mm
- Power supply 400 V (3-phase + N + T)
- Hermetic compressor for remote installation up to 8 metres.

### Options :

- Supplied without compressor unit (KRYO 31)
- Supplied without compressor unit (KRYO 51 -71)
- Remote compressor 8 -20 linear meters for KRYO 31 (for both units)
- Remote compressor 8 -20 linear meters for KRYO 51-71 (for both units)

# Combined blast freezer and conservation unit - **KRYO+**

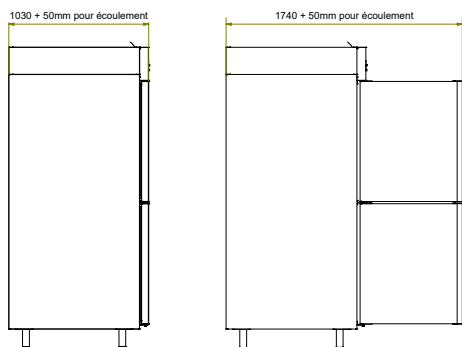
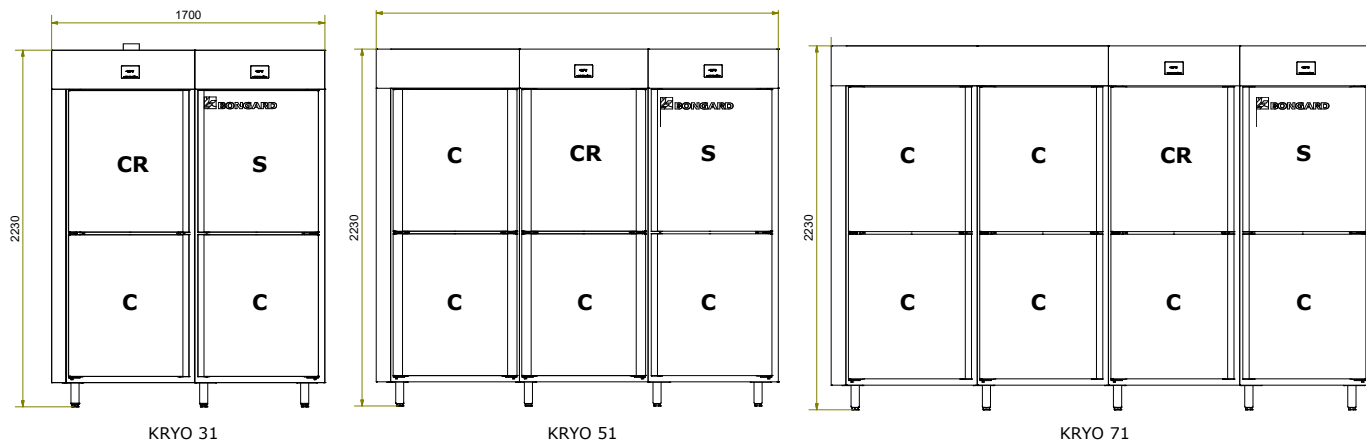

- S** Blast freezer compartment (9 trays 400 x 600 mm, spacing 75 mm, adjustable 25 mm pitch)
- C** Conservation compartment (10 trays 600 x 800 mm, spacing 75 mm, adjustable 37.5 mm pitch)
- CR** Reduced Conservation compartment (4 trays 600 x 800 mm, spacing 75 mm, adjustable 37.5 mm pitch)

--- Important notes:

- The products must necessarily have passed through the blast freezer.
- The temperature of the products must be less than or equal to -18 °C.
- The drain is located at the rear of the cabinet, on the right or left-hand side.
- The unit must be installed in a ventilated room whose ambient temperature is between 13 °C and 30 °C.

General features				
Model		KRYO 31	KRYO 51	KRYO 71
<b>Height</b>				
Front (without refrigeration unit) depending on stands height	(mm)	2230 - 2280		
Front (with refrigeration unit) depending on stands height	(mm)	2470 - 2520	2570 - 2620	2570 - 2620
<b>Width</b>				
Front	(mm)	1700	2500	3300
<b>Depth</b>				
Internal	(mm)	800	800	800
External	(mm)	1030 + 50 mm (condensation drainage)		
Door open	(mm)	1740 + 50 mm (condensation drainage)		

Type	Nb of pans in conservation 400 x 600	Nb of levels in conservation 600 x 800	Nb of pans in blast freezing 400 x 600
KRYO 31	48	24	9
KRYO 51	88	44	9
KRYO 71	128	64	9

**Min. bakehouse height under ceiling 2,700 mm**

Energetic features					
Model	Blast freezer		Conservation unit		
	31-51-71		31	51	71
<b>Power input</b>					
Conservation unit (standard)	(ch)	2	2	2	3
Defrosting	(kW)	-	2,6	2,6	2,6
Heating cord	(kW)	0,035	0,105	0,175	0,245
Connection capacity	(kW)	-	8	8	8
Ø Suction valve		5/8"	5/8"	5/8"	7/8"
Ø Liquid outlet valve		3/8"	3/8"	3/8"	3/8"
Minimum recommended insulating foam thickness	(mm)	19			
Quantity of R452A gas (depending on unit distance)	(kg)	1,5	1,5	1,5	1,5
<b>Unit dimensions</b>					
Height	(mm)	440	440	540	540
Width	(mm)	520	520	520	520
Depth	(mm)	610	610	630	630
Weight of the unit	(kg)	57	57	79	79
Refrigerating capacity at -30°C/+32°C	(kW)	1,96	1,65	1,65	1,96
Discharge of condensates	(mm)	Ø 32			
Electrical supply		400 V Tri + N + T			

■ Standard | □ Option | ❖ N/a

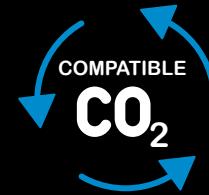

## Roll-in blast freezer

### Performances

- BSC 46.1 : 1 rack, tray size 400 x 600 mm
- BSC 68.1 : 1 rack, tray size 600 x 800 or 2 racks, tray size 400 x 600 mm
- BSC 810.1 : 1 rack, tray size 800 x 1000 or 2 racks, tray size 400 x 800 mm
- BSC 810.2 : 2 racks, tray size 800 x 1000 or 3 racks, tray size 600 x 800 mm

### The advantages

- 4 models available
- 2 programmes: blast freezing and blast chilling
- Electronic regulation with pin type sensor
- Automatic switching at the end of the blast freezing cycle to conservation mode over 24 hours maximum
- Special deep freezing ventilator
- Stainless steel interior for easy cleaning
- Refrigerator installation ready to use on R 452A

### Use

The roll-in BSC blast freezer is designed to chill and rapidly freeze products before conservation.

### Operating principle

With its electromechanical control which autonomously controls the temperature and time needed to freeze products, the BSC is capable of controlling cold production to reach -18°C at core, as rapidly as possible (30 kg to 130 kg of raw baguettes per hour, depending on the model). Once this temperature has been reached, it regulates it for 24 hours and automatically switches to conservation mode at the end of cycle.

### • BSC features:

- 2 programmes : blast freezing and blast chilling
- Buzzer at end of pre-cooling and at end of cycle
- Automatic switching at end of freezing cycle to conservation mode
- Alternated display of temperature at core and actual time
- Ventilation stops at door opening
- Refrigerating fluid R 452 A which preserves the ozone layer
- Hermetic spiral refrigeration unit ("Scroll" type)
- Anti-corrosion evaporator
- Sheet panels and screws in stainless steel
- "special cold" ventilation fan
- Recovery tray for defrosting water
- Right or left side drain Ø 32 mm from 0 to 0,1 m maximum from the floor

### Construction

- Isothermal panel (80 mm thick) made of injected polyurethane foam 42 Kg/m<sup>3</sup>
- Panels assembled by eccentric hooks
- Stainless steel coating 6/10 304 thickness interior and 6/10 electro zined steel coated with a protective food grade PVC of 120 micron thick exterior
- Insulated stainless steel floor with access ramp
- Stainless steel interior protection
- Gasket clipped on the door
- Heated door gasket
- Hermetic compressor with HPLP pressure controller supplied to be installed and connected up to 8 m

### • • • Important note :

The appliance should be installed in ventilated premises at an ambient temperature between 13°C and 30°C.

# Roll-in blast freezer **BSC**

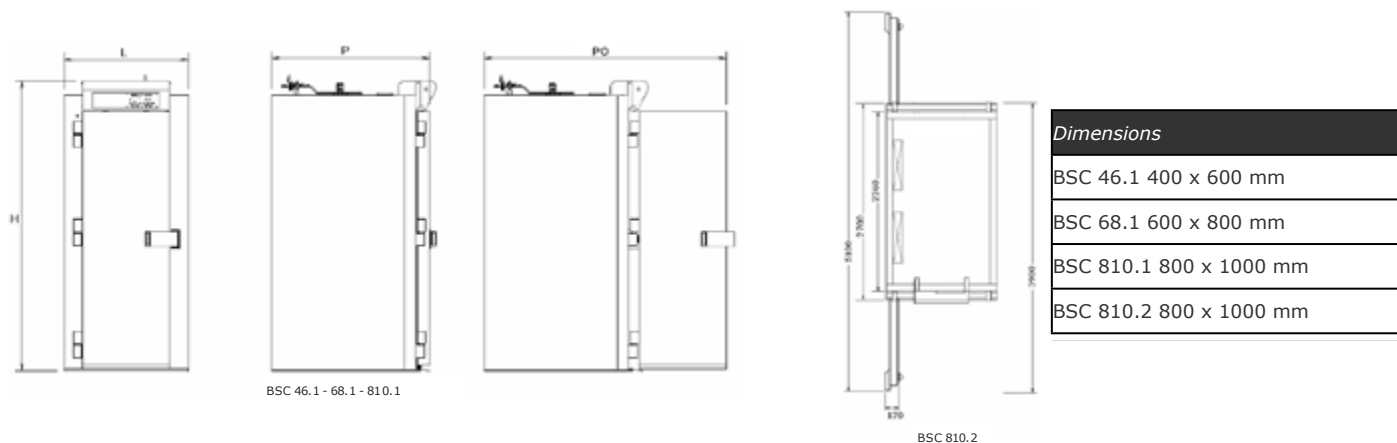

<b>General features</b>						
<b>Model</b>		<b>BSC 46.1</b>	<b>BSC 68.1</b>	<b>BSC 810.1</b>	<b>BSC 810.2</b>	
Capacity (rack)		1 x (400 x 600)	1 x (600 x 800)	1 x (800 x 1000)	2 x (800 x 1000)	
			2 x (400 x 600)	2 x (400 x 800)	3 x (600 x 800)	
Front height (H)	(mm)	2 230	2 230	2 230	2 230	
Useful height	(mm)	200	200	200	200	
Width front (L)	(mm)	940	1 340	1 340	1 460	
Exterior depth (P)	(mm)	1 200	1 200	1 680	2 700	
Depth (door opened) (PO)	(mm)	1882	2 282 mm	2762 mm	1200(*)	1 door opened
					2400(**)	2 doors opened
Floor area	(m <sup>2</sup> )	1	1.55	2.30	3.50	
Compartment weight	(kg)	250	340	420	750	
Blast freezing capacity (at core +22°C): baguettes 350 g of dough	( kg / hour)	30	60	70	130	
Maximum dough weight per piece	(kg)	1,8	1.8	1.8	1.8	
Door clearance	(mm)	550	953	953	920	
Useful depth	(mm)	660	720	1 200	2 220	
Maximum rack height	(mm)	1 900	1 900	1 900	1 900	
<b>Dimensions of refrigeration unit (installed up to 8 m)</b>						
Height	(mm)	533	650	650	650	
Width	(mm)	735	950	1 130	1 130	
Depth	(mm)	680	740	820	820	
Ø copper pipe, "suction"		7/8»	1-1/8"	1-1/8"	1-1/8"	
Ø copper pipe, «liquid»		3/8»	3/8»	1/2»	1/2»	

(\*) 1 door / (\*\*\*) 2 doors

<b>General features</b>					
<b>Model</b>		<b>BSC 46.1</b>	<b>BSC 68.1</b>	<b>BSC 810.1</b>	<b>BSC 810.2</b>
<b>Electric power</b>					
Hermetic spiral compressor ("Scroll" type) (remote)	(ch)	3.5	7.5	10	2 x 10
Heating gasket	(kW)	0,4	0,4	0,4	0,8
Total	(kW)	3,7	9	10,5	2 x 10,5
Frigorific power from -40°C to +32°C	(kW)	2	4	4,5	2 x 4,5
Frigorific power when connected to central refrigeration plant	(kW)	2,8	5,2	6,9	13,8
Power supply		400 V 3 PH + N + T 50 Hz			





## Conservation unit & Reach-in Conservation Units

### Characteristics

- 2 (KRYO 20) to 8 doors (KRYO 80)
- 28 to 148 400x600 mm trays, 75 mm spacing, adjustable with a 37.5 mm pitch
- Electronic capacitive touch interface
- Automatic door opening detector
- Fan stops when doors opened

### The advantages

- Conservation modules with 1 compressor and 1 control unit
- Panels assembled using excentric hooks
- Removable stainless steel hook racks and tray slides (37 mm pitch)
- Easily accessible heating cords around doors
- KRYO can be expanded according to your requirements
- Refrigeration installation (R 452A)

### Use

The KRYO tray-type conservation unit is designed to conserve products after blast freezing.

### Operating principle

After blast freezing, the products are stored in the conservation unit at a temperature of  $-18^{\circ}\text{C}$  /  $-22^{\circ}\text{C}$ . The control manages the temperature and displays it during the current cycle.

### KRYO special features

- Electronic capacitive touch interface
- Evaporator enabling an increase in the conservation unit's storage capacity. Unit replacement required depending on the models

### Construction

- Enclosure and door: isothermal panels 80 mm thick injected with high density  $42\text{ kg/m}^3$ , 90 mm thick for the floor.
- Panels on the inside of the unit are covered with stainless steel sheeting, and with electro-galvanised hot-dipped sheet metal covered with a protective food-grade "PET" film on the outside.
- Sheet panels of the evaporator in stainless steel
- Trim panel on upper part of equipment
- Doors equipped with magnetic seal and spring pivot door return system, easy to remove without tools
- Equipment mounted on stainless steel feet adjustable from 150 to 200 mm
- Power supply 400 V (3-phase + N + T)
- Hermetic compressor for remote installation up to 6 meters
- Quick change of door handle direction on site

### Important comment :

The unit must be installed in a ventilated room whose ambient temperature between  $13^{\circ}\text{C}$  and  $30^{\circ}\text{C}$ .

### In option:

- Supplied without compressor unit (KRYO 20-40)
- Supplied without compressor unit (KRYO 60-80)
- Remote compressor 8-20 linear meters for KRYO 20-40
- Remote compressor 8-20 linear meters for KRYO 60-80



# Conservation unit **KRYO**

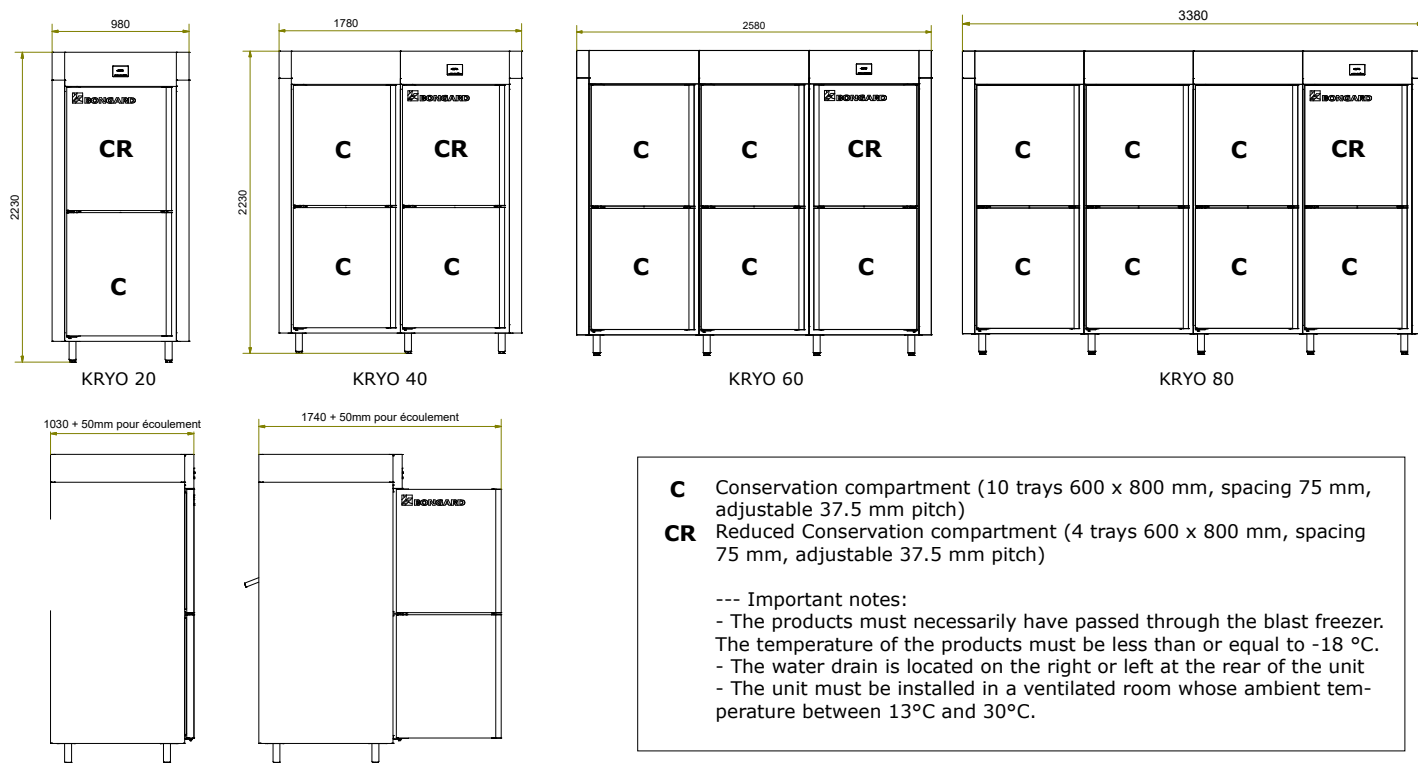

General characteristics					
Model		KRYO 20	KRYO 40	KRYO 60	KRYO 80
<b>Height</b>					
Front (without refrigeration unit)	(mm)	2230 - 2280			
Front (with refrigeration unit) min-max depending on foot height	(mm)	2470 - 2520			
<b>Width</b>					
Front	(mm)	980	1780	2580	3380
<b>Depth</b>					
Interior	(mm)	800			
Surface	(mm)	1030			
	(mm)	1030 + 50 (condensation drainage)			
Door open	(mm)	1740 + 50 (condensation drainage)			
Min. bakehouse height with unit mounted 2,700 mm					

Type	Nb of pans in conservation 400 x 600	Nb of levels in conservation 600 x 800
KRYO 20	28	14
KRYO 40	68	34
KRYO 60	108	54
KRYO 80	148	74

Energetic features					
Model		20	40	60	80
<b>Power input</b>					
Conservation unit (standard)	(ch)	1,5	2	2	3
Defrosting	(kW)	2.6			
Heating cord	(kW)	0,07	0,14	0,21	0,28
Connection capacity	(kW)	5	6	6	8
Ø suction valve		5/8"			
Ø liquid outlet valve		3/8"			
Minimum thickness of insulating foam recommended	(mm)	19			
Quantity of R452A gas (depending on unit distance)	(kg)	1,5	1,5	1,5	1,5
<b>Unit dimensions</b>					
Height	(mm)	450	440	440	440
Width	(mm)	520	520	520	520
Depth	(mm)	610	620	620	620
Weight of the unit	(kg)	46	57	57	57
Refrigerating capacity at -30°C /+30°C	(kW)	1,08	1,65	1,65	1,96
Discharge of condensates	(mm)	Ø 32			
Electrical supply		400 V Tri + N + T			

# Boreal

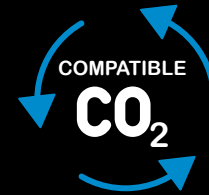

## Walk-in cold room - positive temperature

### Characteristics

- The rooms are characterized by their storage capacity, expressed in m<sup>3</sup>, and by their interior dimensions: width and depth
- They are available with 3 different interior heights: 2 m, 2.25 m and 2.4 m

### The advantages

- **A fully modular line**
- **A robust, top-quality construction**
  - Panels custom made in our plant
  - Panel finishing composed of a 120- $\mu$  thick layer of stiff, scratch-resistant and humidity-resistant PVC
- **Fully equipped as a standard feature:**
  - LED lighting
  - Self-defrosting
- **Rooms simple and quick to assemble**

### Use

The Boreal rooms are used to store and conserve bakery and pastry products.

### Operating principle

The ingredients are stored on shelves or in storage racks inside the room.

### Construction

#### **Panels**

Injected polyurethane foam, density: 42 kg/m<sup>3</sup>  
Galvanized steel lining covered by a food-grade PVC film 120 microns thick  
Composed of 60-mm isothermal panels  
15-mm insulated floor or 17-mm stainless steel reinforced insulated floor as an option

#### **Doors**

Solid, composition identical to that of the panels,  
single leaf, reversible on-site  
Ergonomic door handle Wear-resistant door hinges

#### **Technical elements**

Ceiling-mounted evaporator  
Self-defrosting  
Automatic shutdown of open-door ventilation  
Temperature recorder and safety kit for spaces larger than 10 m<sup>3</sup>  
LED ceiling light fixture triggered by door opening

#### **Assembly**

The panels are to be assembled on-site  
Assembly of panels by means of excentric hooks

## Walk-in cold room - positive temperature **Boreal**

Boreal	Positive
<b>Controls</b>	
Basic electronic controls	■
<b>Construction: panels</b>	
Both interior and exterior made with PVC-lined steel	■
Stainless steel interior and PVC exterior	-
Stainless steel interior and exterior	€
<b>Construction: door</b>	
Left door handle	■
Right door handle	□
Reversible door	■
Double-leaf door	-
2 doors on the front	-
2 "tunnel" doors	-
Temperature read out at opposite side in the case tunnel model	-
Interior and exterior protection door bumpers	-
Interior protective bumpers rails	-
Spiral ramp door hinges (raises door while opening)	■
Rack entry : by the small dimension	-
Rack entry : by the large dimension	-
Door heating gasket and pressure relief valve	-
<b>Equipment - fit-out</b>	
Ceiling-mounted evaporator with single-flow technology	■
Ceiling-mounted evaporator with double-flow technology	-
Automatic-defrosting	■
Automatic ventilation shutdown at door opening	■
Ceiling-mounted light fixture triggered by door opening	■
Temperature recorder and safety kit for room volume ≥10 m <sup>3</sup>	■
Without walk-in floor	■
Insulated walk-in floor, skid resistant, 15-mm thick with its 280-mm deep stainless steel access ramp	€
Insulated, stainless steel walk-in floor, skid resistant, 17-mm thick with its 280-mm deep access ramp	€
Insulated walk-in floor, skid resistant, 90-mm thick	-
Reinforced insulated floor 90-mm thick, for heavy load racks	-
Stainless steel-reinforced access ramp	-
Strip curtain	€
<b>Refrigerating unit</b>	
Tropicalized (recommended option with refrigerants R448A and R449A)	■
Remote and tropicalized (recommended option with refrigerants R448A and R449A)	€
Silent and tropicalized standard unit	€
Silent, remote and tropicalized standard unit	€
Silent, tropicalized PREMIUM unit (SCROLL - refrigerants R448A, R449A)	€
Silent, remote, tropicalized PREMIUM unit (SCROLL - refrigerants R448A, R449A)	€
<b>Assembly</b>	
Delivered disassembled	■
<b>Power supply</b>	
400 3PH+N+G 50 Hz	■
440 3PH+N+G 60 Hz	€
208/220 3PH+N+G 60 Hz	€
Other voltage*	€

In case Boreal is to be connected on factory's central refrigeration system: consult us

\*Maximum 7-week delivery period for the other voltages.

# Walk-in cold room - positive temperature **Boreal**

Refrigerating equipment									
Boreal			Positive						
Processed volume	(m <sup>3</sup> )	> 6,8	6,8 - 10,6	10,6 - 13,1	13,1 - 14,9	14,9 - 19,3	19,3 - 24,9	24,9 - 27,9	27,9 - 36,4
Type of evaporator		Ceiling fixture with self-defrosting							
Available liquid refrigerants		R452A / R449A / R448A							
Electrical power	(kW)	2	2	4	4	6	6	6	6
Intensity	(A)	6	6	8	8	10	10	10	10
Information relative to the standard power unit									
Voltage	(V / Hz)	MONO 220-240 / 50	TRI 400-440 / 50-60						
Refrigeration power at -10°C	(kW)	0,95	1,4	1,7	1,9	2,4	3	3,4	4,8
Information relative to the noise reduction unit									
Voltage	(V / Hz)	TRI 400-440 / 50-60							
Refrigeration power at -10°C	(kW)	0,95	1,4	1,7	1,9	2,4	3	3,4	4,8
Information relative to the premium noise reduction unit (Scroll technology - exclusively with refrigerants R448 and R449)									
Voltage	(V / Hz)	Unavailable						TRI 380 - 420 / 50	
Refrigeration power at -10°C	(kW)	Unavailable						3,58	4,24

Dimensional characteristics						
Exterior dimensions						
Type of room	Width (mm)	Depth (mm)	Spacing (mm)	Height (mm)		
				Standard	Floor option	
				Without a floor	Walk-in floor	Reinforced insulated floor
2000	1840 - 4120	1270 - 3550	190	2065	2080	2160
2250				2316	2330	2410
2400				2471	2486	2572

Type of room	Effective interior dimensions				Door			
	Height	Width	Depth	Volume	Free clearance between panels	Maximum height	Door clearance	Type of door
	(mm)	(mm)	(mm)	M3	(mm)	(mm)	(mm)	
Boreal P200	2000	1720 - 4000	1115 - 3430	3,9 - 27,5	690	1800	880	Single door
Boreal P225	2250				930	1950	1120	
Boreal P240	2400				930	1950	1120	

# Boreal

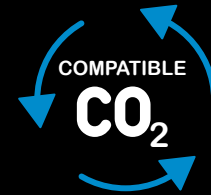

## Walk-in cold room - negative temperature

### Characteristics

- The rooms are characterized by their storage capacity, expressed in m<sup>3</sup>, and by their interior dimensions: width and depth
- They are available with 3 different interior heights: 2 m, 2.25 m and 2.4 m

### The advantages

- A fully modular line
- A robust, top-quality construction
  - Panels custom made in our plant
  - Panel finishing composed of a 120- $\mu$  thick layer of stiff, scratch-resistant and humidity-resistant PVC
- Fully equipped as a standard feature:
  - LED lighting
  - Self-defrosting
- Rooms simple and quick to assemble

### Use specifications

The Boreal rooms are used to store and conserve bakery products.

### Operating principle

The ingredients are stored on shelves or in storage carts inside the room. The conservation temperature is set at -20°C for the Boreal negative temperature rooms.

### Construction

#### Panels

Injected polyurethane foam, density: 42 kg/m<sup>3</sup>  
Galvanized steel lining covered by a food-grade PVC film 120 microns thick  
Composed of 30-mm isothermal panels with an insulated 90-mm floor  
Reinforced, insulated floor to withstand a 90-mm live load available as an option  
Door heating cable and pressure relief valve  
Equipped with a strip curtain

#### Doors

Solid, composition identical to that of the panels, single leaf, reversible on-site  
Ergonomic handle  
Wear-resistant door jamb hinges

#### Technical elements

Ceiling-mounted evaporator  
Self-defrosting  
Automatic shutdown of open-door ventilation  
Temperature recorder and safety kit for spaces larger than 10 m<sup>3</sup>  
LED ceiling light fixture triggered by door opening

#### Assembly

The panels are to be assembled on-site  
Assembly of panels by means of edge hooks  
It should be noted that a 130-mm drop is required to install a negative temperature room.  
An access ramp would be necessary in the absence of an elevation drop.

## Negative temperature conservation **Boreal**

Boreal	Negative
<b>Controls</b>	
Basic electronic controls	■
<b>Construction: panels</b>	
Both interior and exterior made with PVC-lined steel	■
Stainless steel interior and PVC exterior	-
Stainless steel interior and exterior	€
<b>Construction: door</b>	
Left door handle	■
Right door handle	□
Reversible door	■
Double-leaf door	-
2 doors on the front	-
2 "tunnel" doors	-
Temperature read out at opposite side in the case tunnel model	-
Interior and exterior protection door bumpers	-
Interior protective bumpers rails	-
Spiral ramp door hinges (raises door while opening)	■
Rack entry : by the small dimension	-
Rack entry : by the large dimension	-
Door heating gasket and pressure relief valve	■
<b>Equipment - fit-out</b>	
Ceiling-mounted evaporator with single-flow technology	■
Ceiling-mounted evaporator with double-flow technology	-
Automatic-defrosting	■
Automatic ventilation shutdown at door opening	■
Ceiling-mounted light fixture triggered by door opening	■
Temperature recorder and safety kit for room volume $\geq 10$ m <sup>3</sup>	■
Without walk-in floor	-
Insulated walk-in floor, skid resistant, 15-mm thick with its 280-mm deep stainless steel access ramp	-
Insulated, stainless steel walk-in floor, skid resistant, 17-mm thick with its 280-mm deep access ramp	-
Insulated walk-in floor, skid resistant, 90-mm thick	■
Reinforced insulated floor 90-mm thick, for heavy load racks	€
Stainless steel-reinforced access ramp	€
Strip curtain	■
<b>Refrigerating unit</b>	
Tropicalized (recommended option with refrigerants R448A and R449A)	■
Remote and tropicalized (recommended option with refrigerants R448A and R449A)	€
Silent and tropicalized standard unit	€
Silent, remote and tropicalized standard unit	€
Silent, tropicalized PREMIUM unit (SCROLL - refrigerants R448A, R449A)	€
Silent, remote, tropicalized PREMIUM unit (SCROLL - refrigerants R448A, R449A)	€
<b>Assembly</b>	
Delivered disassembled	■
<b>Power supply</b>	
400 3PH+N+G 50 Hz	■
440 3PH+N+G 60 Hz	€
208/220 3PH+N+G 60 Hz	€
Other voltage*	€

In case Boreal is to be connected on factory's central refrigeration system: consult us

\*Maximum 7-week delivery period for the other voltages.

## Negative temperature conservation **Boreal**

<b>Refrigerating equipment</b>							
<b>Boreal</b>		<b>Negative temperature</b>					
<b>Volume</b>	<b>(m<sup>3</sup>)</b>	> 6,8	6,8 - 10,5	10,5 - 14,2	14,2 - 23	23 - 33	33 - 49
Type of evaporator	Ceiling fixture with enhanced self-defrosting						
Liquid	R452A / R449A / R448A						
Electrical power	(kW)	6	6	8	0	8	14
Intensity	(A)	8	8	10	0	12	20
<b>Informations relatives au groupe standard</b>							
Type of unit		Piston					Scroll
Voltage	(V / Hz)	TRI 400-440 / 50-60					TRI 380-420 / 50
Refrigeration power at -10°C	(kW)	1,1	1,7	2,1	3,2	3,9	5,9
<b>Information relative to the noise reduction unit</b>							
Voltage	(V / Hz)	TRI 400-440 / 50-60					-
Refrigeration power at -10°C	(kW)	1,1	1,7	2,1	3,2	3,9	-
<b>Information relative to the premium noise reduction unit (Scroll technology - exclusively with refrigerants R448 and R449)</b>							
Voltage	(V / Hz)	Unavailable		TRI 380 -420 / 50			
Refrigeration power at -10°C	(kW)	Unavailable		2,3	3,2	4,86	6,85

<b>Dimensional characteristics</b>						
<b>Type</b>	<b>Exterior dimensions</b>					
	<b>Width (mm)</b>	<b>Depth (mm)</b>	<b>Spacing (mm)</b>	<b>Height (mm)</b>		
				<b>Standard</b>	<b>Floor option</b>	
				<b>90-mm floor or reinforced insulated floor</b>		
<b>Negative</b>	Boreal N200	1900 - 4180	1330 - 3610	190	2220	
	Boreal N225				2482	
	Boreal N240				2632	

<b>Type</b>	<b>Effective interior dimensions</b>					<b>Door</b>			
	<b>Height (mm)</b>	<b>Width (mm)</b>	<b>Depth (mm)</b>	<b>Volume M3</b>	<b>Free clearance between panels (mm)</b>	<b>Maximum height (mm)</b>	<b>Door clearance (mm)</b>	<b>Type of door</b>	
<b>Negative</b>	Boreal N200	2000	1720 - 4000	1115 - 3430	4 - 27,5	690	1800	880	Simple door
	Boreal N225	2250				930	1950	1120	
	Boreal N240	2400				930	1950	1120	

# Boreal Paneo



## Dough retarding

### Characteristics

- The rooms are characterized by their capacity in terms of number of carts 400 x 600 (effective dimensions = 530 x 670) or 600 x 800 (effective dimensions = 670 x 870).
- The effective interior height of the product line is 1,830 mm.

### The advantages

- **Outstanding dough conservation quality:**
    - Double-flow technology
    - Optimized design of the evaporator exchange surface for the dough storage capacity in the room
    - Top-of-the-line refrigeration equipment, adapted to the various refrigerants sold on the market
    - Self-defrosting
  - **A robust, top-quality construction**
    - Panels custom made in our plant
    - Panel finishing composed of a 120- $\mu$  thick layer of stiff, scratch-resistant and humidity-resistant PVC
    - As a standard feature: hydraulic door-closing mechanism, interior and exterior protective door rail
    - **A wide range of room fit-out possibilities**
- Rooms simple and quick to assemble**

### Use specifications

The Boreal Paneotrad rooms are used for cold blocking of the dough tanks for 12 to 72 hours at between 2° and 6°C.  
The rooms may also be used to manage the slow cooking of custom products.

### Operating principle

The dough is stored in tanks on storage carts inside the room.  
A double-flow evaporator equipped with oversized fans that stir air at a very low speed ensures rates of humidity adapted to the products placed in the room, without needing to add water.  
The dough can thus be stored without any risk of drying and without needing to cover the tank surface.  
The temperature setting range to block the cold or slow fermentation extends from 2° to 16°C.

### Construction

#### Panels

Injected polyurethane foam, density: 42 kg/m<sup>3</sup>  
Galvanized steel lining covered by a food-grade PVC film 120 microns thick  
60-mm isothermal panels  
15-mm insulated floor fitted with a stainless steel ramp, available as an option

#### Doors

Solid, composition identical to that of the panels, reversible on-site  
Interior and exterior protective rail as a standard feature  
Hydraulic door-closing mechanism for a perfect seal  
Ergonomic stainless steel handle  
Wear-resistant door jamb hinges  
Available in either a single-leaf or double-leaf version

#### Technical units

Ceiling-mounted evaporator  
Regulation by means of an ambient thermistor  
Self-defrosting  
Automatic shutdown of open-door ventilation  
Options available: ceiling-mounted light fixture triggered by door opening

#### Assembly

The panels are to be assembled on-site



## Boreal Paneotrad - Dough retarding

Boreal	Paneotrad
<b>Controls</b>	
Basic electronic controls	■
<b>Construction: panels</b>	
Both interior and exterior made with PVC-lined steel	■
Stainless steel interior and PVC exterior	€
Stainless steel interior and exterior	€
<b>Construction: door</b>	
Left door handle	■
Right door handle	□
Reversible door	■
Double-leaf door	€
2 doors on the front	€
2 "tunnel" doors	€
Temperature read out at opposite side in the case tunnel model	€
Interior and exterior protection door bumpers	■
Interior protective bumpers rails	€
Spiral ramp door hinges (raises door while opening)	■
Rack entry : by the small dimension	■
Rack entry : by the large dimension	□
Door heating gasket and pressure relief valve	-
<b>Equipment - fit-out</b>	
Ceiling-mounted evaporator with single-flow technology	-
Ceiling-mounted evaporator with double-flow technology	■
Automatic-defrosting	■
Automatic ventilation shutdown at door opening	■
Ceiling-mounted light fixture triggered by door opening	€
Temperature recorder and safety kit for room volume $\geq 10$ m <sup>3</sup>	-
Without walk-in floor	■
Insulated walk-in floor, skid resistant, 15-mm thick with its 280-mm deep stainless steel access ramp	€
Insulated, stainless steel walk-in floor, skid resistant, 17-mm thick with its 280-mm deep access ramp	€
Insulated walk-in floor, skid resistant, 90-mm thick	-
Reinforced insulated floor 90-mm thick, for heavy load racks	-
Stainless steel-reinforced access ramp	-
Strip curtain	-
<b>Refrigerating unit</b>	
Tropicalized (recommended option with refrigerants R448A and R449A)	■
Remote and tropicalized (recommended option with refrigerants R448A and R449A)	€
Silent and tropicalized standard unit	€
Silent, remote and tropicalized standard unit	€
Silent, tropicalized PREMIUM unit (SCROLL - refrigerants R448A, R449A)	€
Silent, remote, tropicalized PREMIUM unit (SCROLL - refrigerants R448A, R449A)	€
<b>Assembly</b>	
Delivered disassembled	■
<b>Power supply</b>	
400 3PH+N+G 50 Hz	■
440 3PH+N+G 60 Hz	€
208/220 3PH+N+G 60 Hz	€
Other voltage*	€

In case Boreal is to be connected on factory's central refrigeration system: consult us

\*Maximum 7-week delivery period for the other voltages.

# Boreal Paneotrad - Dough retarding

## Refrigerating equipment

### Boreal Paneotrad

Capacity in terms of number of carts 400 x 600		2	3	4	5	6	8
Maximum dough mass	(kg)	143	214	286	357	428	571
Type of evaporator		Ceiling-mounted, double-flow					
Available liquid refrigerants		R452A / R449A / R448A					
Electrical power, in kW	(kW)	2,5	2,5	2,5	2,5	2,5	4
Intensity, in A	(A)	12	12	12	12	12	18
Information relative to the standard power unit							
Power	(CV)	7/8	1	1 1/8	1 1/4	1 1/4	2
Voltage	(V / Hz)	MONO 220-240 / 50		TRI 400-440 / 50-60			
Refrigeration power at -10°C	(kW)	1,25	1,53	1,74	2,17	2,17	3,39
Information relative to the noise reduction unit							
Power	(CV)						
Voltage	(V / Hz)	MONO 220-240 / 50		TRI 400-440 / 50-60			
Refrigeration power at -10°C	(kW)	1,25	1,53	1,74	2,17	2,17	3,39

## Refrigerating equipment

### Boreal Paneotrad

Capacity in terms of number of carts 600 x 800		1	2	3	4	5	6
Maximum dough mass	(kg)	143	286	428	571	714	857
Type of evaporator		Ceiling-mounted, double-flow					
Available liquid refrigerants		R452A / R449A / R448A					
Electrical power	(kW)	2,5	2,5	2,5	4	4	4
Intensity	(A)	4	4	6	6	8	8
Information relative to the standard power unit							
Power	(CV)	1	1 1/8	1 1/4	1 1/4	2	2 1/2
Voltage	(V / Hz)	TRI 400-440 / 50-60					
Refrigeration power at -10°C	(kW)	1,53	1,74	2,17	2,17	3,39	4,27
Information relative to the noise reduction unit							
Power	(CV)	1	1 1/8	1 1/4	1 1/4	2	2 1/2
Voltage	(V / Hz)	TRI 400-440 / 50-60					
Refrigeration power at -10°C	(kW)	1,53	1,74	2,17	2,17	3,39	4,27
Information relative to the premium noise reduction unit (SCROLL technology - exclusively with refrigerants R448 and R449)							
Power	(CV)	Unavailable				2	2 1/2
Voltage	(V / Hz)	Unavailable				TRI 380-420 / 50	
Refrigeration power at -10°C	(kW)	Unavailable				3,58	4,24

### Configurations for Boreal Paneotrad

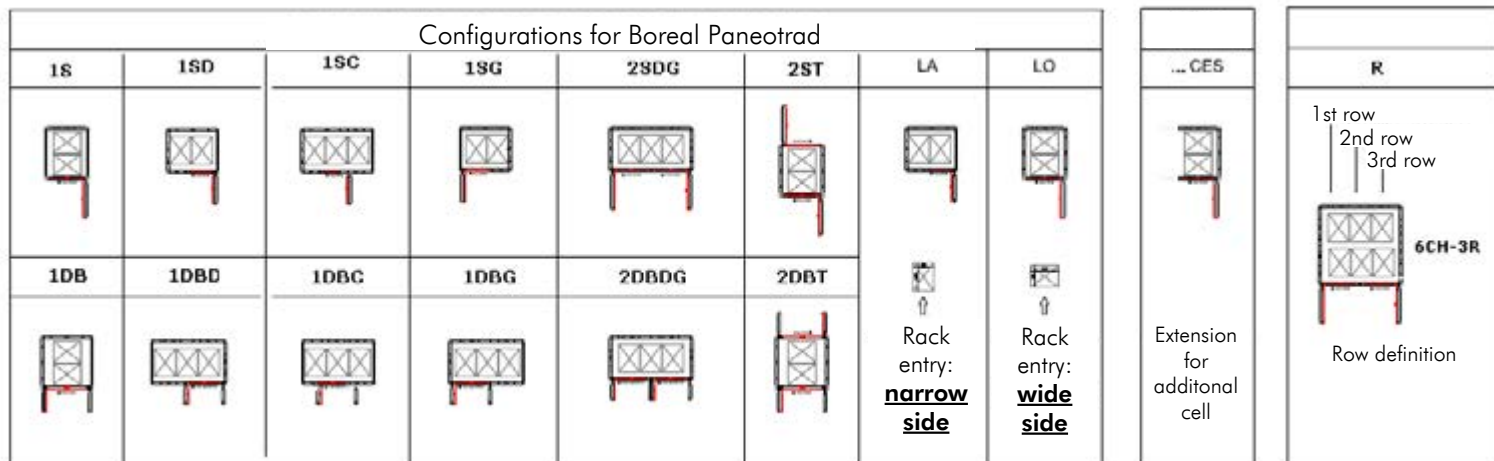

## Boreal Paneotrad - Dough retarding

Ref BOREAL PANEOTRAD	Total number of racks	Number of racks row per cell	Rack entry	Number of front doors	Useful width per door (mm)	Exterior dimensions		Interior dimensions	
						Width (mm)	Depth (mm)	Width (mm)	Depth (mm)
<b>BOREAL PANEOTRAD for racks 400 X 600</b>									
<b>2 racks</b>									
BOREAL-PANEO 2CH 46 1R 1S LO	2	1	600	1	740	1082	1272	950	1140
BOREAL-PANEO 2CH 46 1R 2ST LO	2	1	600	1	740	1082	1272	950	1140
BOREAL-PANEO 2CH 46 2R 1SD LA	2	2	400	1	740	1462	1082	1330	950
BOREAL-PANEO 2CH 46 2R 1SG LA	2	2	400	1	740	1462	1082	1330	950
BOREAL-PANEO 2CH 46 2R 1DB LA	2	2	400	1	1120	1462	1082	1330	950
<b>3 racks</b>									
BOREAL-PANEO 3CH 46 1R 1S LO	3	1	600	1	740	1082	1842	950	1710
BOREAL-PANEO 3CH 46 1R 2ST LO	3	1	600	1	740	1082	1842	950	1710
BOREAL-PANEO 3CH 46 3R 1SD LA	3	3	400	1	740	2032	1082	1900	950
BOREAL-PANEO 3CH 46 3R 1SG LA	3	3	400	1	740	2032	1082	1900	950
BOREAL-PANEO 3CH 46 3R 1SC LA	3	3	400	1	740	1842	1082	1710	950
BOREAL-PANEO 3CH 46 3R 2SDG LA	3	3	400	2	740	2032	1082	1900	950
BOREAL-PANEO 3CH 46 3R 1DB LA	3	3	400	1	1690	2032	1082	1900	950
<b>4 racks</b>									
BOREAL-PANEO 4CH 46 1R 1S LO	4	1	600	1	740	1082	2412	950	2280
BOREAL-PANEO 4CH 46 1R 2ST LO	4	1	600	1	740	1082	2412	950	2280
BOREAL-PANEO 4CH 46 2R 1SD LA	4	2	400	1	740	1462	1652	1330	1520
BOREAL-PANEO 4CH 46 2R 1SG LA	4	2	400	1	740	1462	1652	1330	1520
BOREAL-PANEO 4CH 46 2R 1DB LA	4	2	400	1	1120	1462	1652	1330	1520
BOREAL-PANEO 4CH 46 2R 1SD LO	4	2	600	1	740	1842	1272	1710	1140
BOREAL-PANEO 4CH 46 2R 1SG LO	4	2	600	1	740	1842	1272	1710	1140
BOREAL-PANEO 4CH 46 2R 2SDG LO	4	2	600	2	740	2032	1272	1900	1140
BOREAL-PANEO 4CH 46 4R 1SD LA	4	4	400	1	740	2602	1082	2470	950
BOREAL-PANEO 4CH 46 4R 1SG LA	4	4	400	1	740	2602	1082	2470	950
BOREAL-PANEO 4CH 46 4R 2SDG LA	4	4	400	2	740	2602	1082	2470	950
<b>6 racks</b>									
BOREAL-PANEO 6CH 46 1R 1S LO	6	1	600	1	740	1082	3362	950	3230
BOREAL-PANEO 6CH 46 1R 2ST LO	6	1	600	1	740	1082	3362	950	3230
BOREAL-PANEO 6CH 46 2R 1SD LA	6	2	400	1	740	1462	2412	1330	2280
BOREAL-PANEO 6CH 46 2R 1SG LA	6	2	400	1	740	1462	2412	1330	2280
BOREAL-PANEO 6CH 46 2R 1DB LA	6	2	400	1	1120	1462	2412	1330	2280
BOREAL-PANEO 6CH 46 2R 1SD LO	6	2	600	1	740	1842	1842	1710	1710
BOREAL-PANEO 6CH 46 2R 1SG LO	6	2	600	1	740	1842	1842	1710	1710
BOREAL-PANEO 6CH 46 2R 1DB LO	6	2	600	2	740	2032	1842	1900	1710
BOREAL-PANEO 6CH 46 3R 1SD LO	6	3	600	1	740	2602	1272	2470	1140
BOREAL-PANEO 6CH 46 3R 1SG LO	6	3	600	1	740	2602	1272	2470	1140
BOREAL-PANEO 6CH 46 3R 1SC LO	6	3	600	1	740	2602	1272	2470	1140
BOREAL-PANEO 6CH 46 3R 2SDG LO	6	3	600	2	740	2602	1272	2470	1140
BOREAL-PANEO 6CH 46 3R 1SD LA	6	3	400	1	740	2032	1652	1900	1520
BOREAL-PANEO 6CH 46 3R 1SG LA	6	3	400	1	740	2032	1652	1900	1520
BOREAL-PANEO 6CH 46 3R 2SDG LA	6	3	400	2	740	2032	1652	1900	1520
BOREAL-PANEO 6CH 46 6R 1SD LA	6	6	400	1	740	3742	1082	3610	950
BOREAL-PANEO 6CH 46 6R 1SG LA	6	6	400	1	740	3742	1082	3610	950
BOREAL-PANEO 6CH 46 6R 2SDG LA	6	6	400	2	740	3742	1082	3610	950
<b>8 racks</b>									
BOREAL-PANEO 8CH 46 1R 1S LO	8	1	600	1	740	1082	4502	950	4370
BOREAL-PANEO 8CH 46 1R 2ST LO	8	1	600	1	740	1082	4502	950	4370
BOREAL-PANEO 8CH 46 2R 1SD LA	8	2	400	1	740	1462	3172	1330	3040
BOREAL-PANEO 8CH 46 2R 1SG LA	8	2	400	1	740	1462	3172	1330	3040
BOREAL-PANEO 8CH 46 2R 1DB LA	8	2	400	1	1120	1462	3172	1330	3040
BOREAL-PANEO 8CH 46 2R 1SD LO	8	2	600	1	740	1842	2412	1710	2280
BOREAL-PANEO 8CH 46 2R 1SG LO	8	2	600	1	740	1842	2412	1710	2280
BOREAL-PANEO 8CH 46 2R 2SDG LO	8	2	600	2	740	2032	2412	1900	2280
BOREAL-PANEO 8CH 46 4R 1SD LA	8	4	400	1	740	2602	1652	2470	1520
BOREAL-PANEO 8CH 46 4R 1SG LA	8	4	400	1	740	2602	1652	2470	1520
BOREAL-PANEO 8CH 46 4R 2SDG LA	8	4	400	2	740	2602	1652	2470	1520
BOREAL-PANEO 8CH 46 4R 1SD LO	8	4	600	1	740	3172	1272	3040	1140
BOREAL-PANEO 8CH 46 4R 1SG LO	8	4	600	1	740	3172	1272	3040	1140
BOREAL-PANEO 8CH 46 4R 2SDG LO	8	4	600	2	740	3172	1272	3040	1140
BOREAL-PANEO 8CH 46 8R 1SD LA	8	8	400	1	740	4692	1082	4560	950
BOREAL-PANEO 8CH 46 8R 1SG LA	8	8	400	1	740	4692	1082	4560	950
BOREAL-PANEO 8CH 46 8R 2SDG LA	8	8	400	2	740	4692	1082	4560	950

## Boreal Paneotrad - Dough retarding

Ref BOREAL PANEOTRAD	Total number of racks	Number of racks row per cell	Rack entry	Number of front doors	Useful width per door (mm)	Exterior dimensions		Interior dimensions	
						Width (mm)	Depth (mm)	Width (mm)	Depth (mm)
<b>BOREAL PANEOTRAD for rack 600 X 800</b>									
<b>1 rack</b>									
BOREAL-PANEO 1CH 68 1R 1S LA	1	1	600	1	740	1082	1272	950	1140
BOREAL-PANEO 1CH 68 1R 2ST LA	1	1	600	1	740	1082	1272	950	1140
BOREAL-PANEO 1CH 68 1R 1S LO	1	1	800	1	930	1272	1082	1140	950
BOREAL-PANEO 1CH 68 1R 2ST LO	1	1	800	1	930	1272	1082	1140	950
<b>2 racks</b>									
BOREAL-PANEO 2CH 68 1R 1S LA	2	1	600	1	740	1082	2032	950	1900
BOREAL-PANEO 2CH 68 1R 2ST LA	2	1	600	1	740	1082	2032	950	1900
BOREAL-PANEO 2CH 68 1R 1S LO	2	1	800	1	930	1272	1652	1140	1520
BOREAL-PANEO 2CH 68 1R 2ST LO	2	1	800	1	930	1272	1652	1140	1520
BOREAL-PANEO 2CH 68 2R 1SD LA	2	2	600	1	740	1652	1082	1520	950
BOREAL-PANEO 2CH 68 2R 1SG LA	2	2	600	1	740	1652	1082	1520	950
BOREAL-PANEO 2CH 68 2R 2SDG LA	2	2	600	2	740	2032	1082	1900	950
BOREAL-PANEO 2CH 68 2R 1DB LA	2	2	600	1	1500	1842	1082	1710	950
BOREAL-PANEO 2CH 68 2R 1SD LO	2	2	800	1	930	2222	1082	2090	950
BOREAL-PANEO 2CH 68 2R 1SG LO	2	2	800	1	930	2222	1082	2090	950
BOREAL-PANEO 2CH 68 2R 2SDG LO	2	2	800	2	930	2412	1082	2280	950
<b>3 racks</b>									
BOREAL-PANEO 3CH 68 1R 1S LA	3	1	600	1	740	1082	2792	950	2660
BOREAL-PANEO 3CH 68 1R 2ST LA	3	1	600	1	740	1082	2792	950	2660
BOREAL-PANEO 3CH 68 1R 1S LO	3	1	800	1	930	1272	2222	1140	2090
BOREAL-PANEO 3CH 68 1R 2ST LO	3	1	800	1	930	1272	2222	1140	2090
BOREAL-PANEO 3CH 68 3R 1SD LA	3	3	600	1	740	2412	1082	2280	950
BOREAL-PANEO 3CH 68 3R 1DB LA	3	3	600	1	740	2412	1082	2280	950
BOREAL-PANEO 3CH 68 3R 1DBC LA	3	3	600	1	1120	2222	1082	2090	950
BOREAL-PANEO 3CH 68 3R 1SG LA	3	3	600	1	740	2412	1082	2280	950
BOREAL-PANEO 3CH 68 3R 2SDG LA	3	3	600	2	740	2412	1082	2280	950
BOREAL-PANEO 3CH 68 3R 1SD LO	3	3	800	1	930	2982	1082	2850	950
BOREAL-PANEO 3CH 68 3R 1SG LO	3	3	800	1	930	2982	1082	2850	950
BOREAL-PANEO 3CH 68 3R 2SDG LO	3	3	800	2	930	2982	1082	2850	950
<b>4 racks</b>									
BOREAL-PANEO 4CH 68 1R 1S LA	4	1	600	1	740	1082	3742	950	3610
BOREAL-PANEO 4CH 68 1R 1S LO	4	1	800	1	930	1272	2982	1140	2850
BOREAL-PANEO 4CH 68 1R 2ST LA	4	1	600	1	740	1082	3742	950	3610
BOREAL-PANEO 4CH 68 1R 2ST LO	4	1	800	1	930	1272	2982	1140	2850
BOREAL-PANEO 4CH 68 2R 1SD LA	4	2	600	1	740	1652	2032	1520	1900
BOREAL-PANEO 4CH 68 2R 1SG LA	4	2	600	1	740	1652	2032	1520	1900
BOREAL-PANEO 4CH 68 2R 2SDG LA	4	2	600	2	740	2032	2032	1900	1900
BOREAL-PANEO 4CH 68 2R 1DB LA	4	2	600	1	1500	1842	2032	1710	1900
BOREAL-PANEO 4CH 68 2R 1SD LO	4	2	800	1	930	2222	1652	2090	1520
BOREAL-PANEO 4CH 68 2R 1SG LO	4	2	800	1	930	2222	1652	2090	1520
BOREAL-PANEO 4CH 68 2R 2SDG LO	4	2	800	2	930	2412	1652	2280	1520
BOREAL-PANEO 4CH 68 4R 1SD LA	4	4	600	1	740	2982	1082	2850	950
BOREAL-PANEO 4CH 68 4R 1SG LA	4	4	600	1	740	2982	1082	2850	950
BOREAL-PANEO 4CH 68 4R 2SDG LA	4	4	600	2	740	3172	1082	3040	950
BOREAL-PANEO 4CH 68 4R 1SD LO	4	4	800	1	930	3932	1082	3800	950
BOREAL-PANEO 4CH 68 4R 1SG LO	4	4	800	1	930	3932	1082	3800	950
BOREAL-PANEO 4CH 68 4R 2SDG LO	4	4	800	2	930	3932	1082	3800	950

## Boreal Paneotrad - Dough retarding

Ref BOREAL PANEOTRAD	Total number of racks	Number of racks of row per cell	Rack entry	Number of front doors	Useful width per door (mm)	Exterior dimensions		Interior dimensions	
						Width (mm)	Depth (mm)	Width (mm)	Depth (mm)
<b>6 racks</b>									
BOREAL-PANEO 6CH 68 1R 1S LA	6	1	600	1	740	1082	5452	950	5320
BOREAL-PANEO 6CH 68 1R 2ST LA	6	1	600	1	740	1082	5452	950	5320
BOREAL-PANEO 6CH 68 1R 1S LO	6	1	800	1	930	1272	4312	1140	4180
BOREAL-PANEO 6CH 68 1R 2ST LO	6	1	800	1	930	1272	4312	1140	4180
BOREAL-PANEO 6CH 68 2R 1SD LA	6	2	600	1	740	1652	2982	1520	2850
BOREAL-PANEO 6CH 68 2R 1SG LA	6	2	600	1	740	1652	2982	1520	2850
BOREAL-PANEO 6CH 68 2R 2SDG LA	6	2	600	2	740	2032	2982	1900	2850
BOREAL-PANEO 6CH 68 2R 1DB LA	6	2	600	1	1500	1842	2982	1710	2850
BOREAL-PANEO 6CH 68 2R 1SD LO	6	2	800	1	930	2222	2222	2090	2090
BOREAL-PANEO 6CH 68 2R 1DBD LO	6	2	800	1	930	2222	2222	2090	2090
BOREAL-PANEO 6CH 68 2R 1SG LO	6	2	800	1	930	2222	2222	2090	2090
BOREAL-PANEO 6CH 68 2R 2SDG LO	6	2	800	2	930	2412	2222	2280	2090
BOREAL-PANEO 6CH 68 3R 1SD LA	6	3	800	1	740	2412	2032	2280	1900
BOREAL-PANEO 6CH 68 3R 1SG LA	6	3	600	1	740	2412	2032	2280	1900
BOREAL-PANEO 6CH 68 3R 2SDG LA	6	3	600	2	740	2412	2032	2280	1900
BOREAL-PANEO 6CH 68 3R 1SD LO	6	3	800	1	930	2982	1652	2850	1520
BOREAL-PANEO 6CH 68 3R 1SG LO	6	3	800	1	930	2982	1652	2850	1520
BOREAL-PANEO 6CH 68 3R 2SDG LO	6	3	800	2	930	2982	1652	2850	1520
BOREAL-PANEO 6CH 68 6R 1SD LA	6	6	600	1	740	4502	1082	4370	950
BOREAL-PANEO 6CH 68 6R 1SG LA	6	6	600	1	740	4502	1082	4370	950
BOREAL-PANEO 6CH 68 6R 2SDG LA	6	6	600	2	740	4502	1082	4370	950
BOREAL-PANEO 6CH 68 6R 2SDG LO	6	6	800	2	930	5642	1082	5510	950
BOREAL-PANEO 6CH 68 6R 1SD LO	6	6	800	1	930	5642	1082	5510	950
BOREAL-PANEO 6CH 68 6R 1SG LO	6	6	800	1	930	5642	1082	5510	950
<b>8 racks</b>									
BOREAL-PANEO 8CH 68 1R 1S LA	8	1	600	1	740	1082	7352	950	7220
BOREAL-PANEO 8CH 68 1R 2ST LA	8	1	600	1	740	1082	7352	950	7220
BOREAL-PANEO 8CH 68 1R 1S LO	8	1	800	1	930	1272	6402	1140	6270
BOREAL-PANEO 8CH 68 1R 2ST LO	8	1	800	1	930	1272	6402	1140	6270
BOREAL-PANEO 8CH 68 2R 1SD LA	8	2	600	1	740	1842	3742	1710	3610
BOREAL-PANEO 8CH 68 2R 1SG LA	8	2	600	1	740	1842	3742	1710	3610
BOREAL-PANEO 8CH 68 2R 2SDG LA	8	2	600	2	740	2032	3742	1900	3610
BOREAL-PANEO 8CH 68 2R 1DB LA	8	2	600	1	1500	1842	3742	1710	3610
BOREAL-PANEO 8CH 68 2R 1SD LO	8	2	800	1	930	2222	2982	2090	2850
BOREAL-PANEO 8CH 68 2R 1SG LO	8	2	800	1	930	2222	2982	2090	2850
BOREAL-PANEO 8CH 68 2R 2SDG LO	8	2	800	2	930	2412	2982	2280	2850
BOREAL-PANEO 8CH 68 4R 1SD LA	8	4	600	1	740	3172	2032	3040	1900
BOREAL-PANEO 8CH 68 4R 1SG LA	8	4	600	1	740	3172	2032	3040	1900
BOREAL-PANEO 8CH 68 4R 2SDG LA	8	4	600	2	740	3172	2032	3040	1900
BOREAL-PANEO 8CH 68 4R 1SD LO	8	4	800	1	930	3932	1652	3800	1520
BOREAL-PANEO 8CH 68 4R 1SG LO	8	4	800	1	930	3932	1652	3800	1520
BOREAL-PANEO 8CH 68 4R 2SDG LO	8	4	800	2	930	3932	1652	3800	1520
BOREAL-PANEO 8CH 68 8R 2SDG LA	8	8	600	2	740	6022	1082	5890	950
BOREAL-PANEO 8CH 68 8R 2SDG LO	8	8	800	2	930	7542	1082	7410	950
<p>Exterior height: 2320 mm (+ 15 mm insulated floor)</p> <p>Useful interior height: 1830 mm</p>									

# Boreal Paneotrad 400x600 - 2 racks

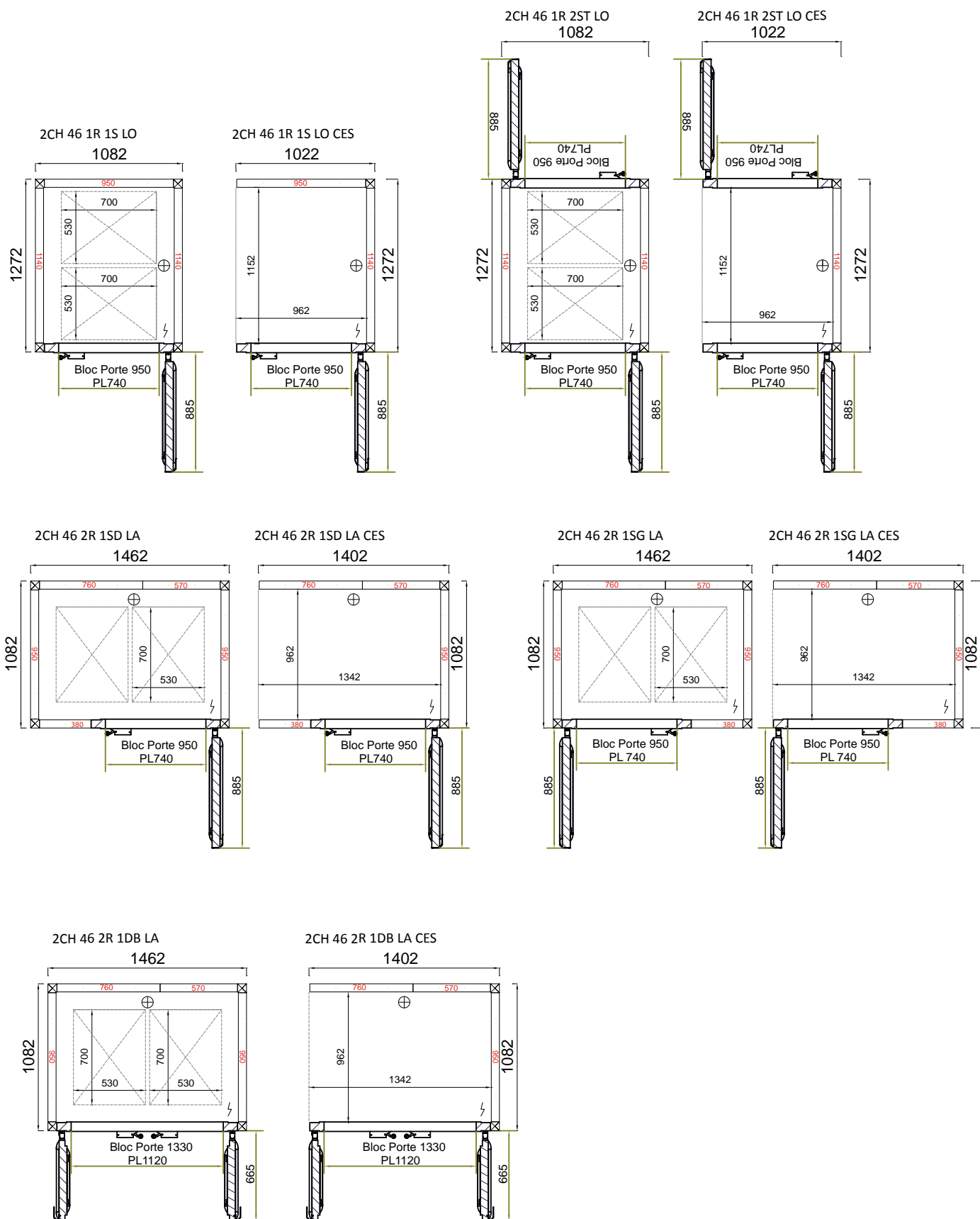

# Boreal Paneotrad 400x600 - 3 racks

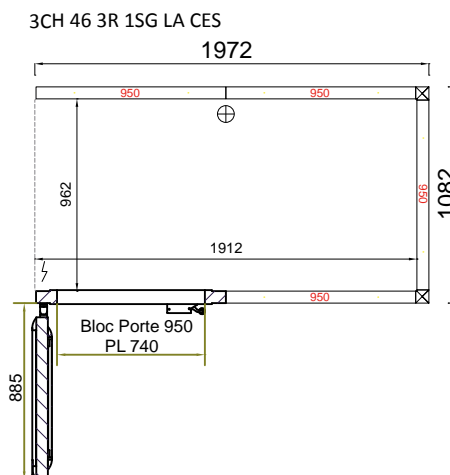
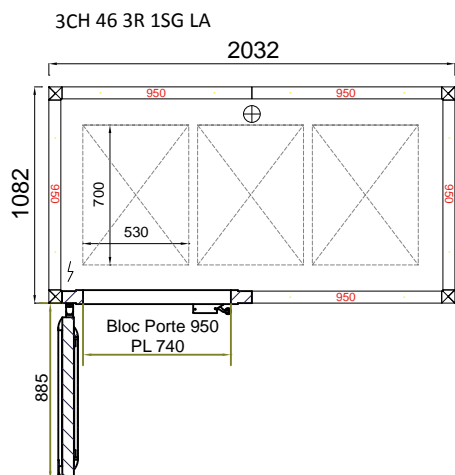
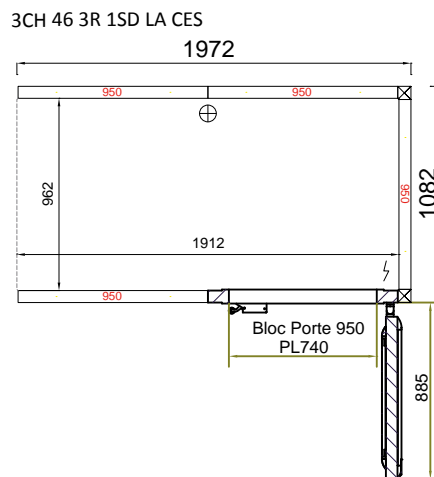
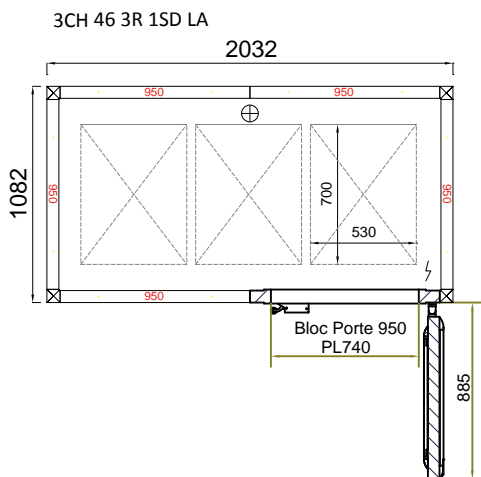
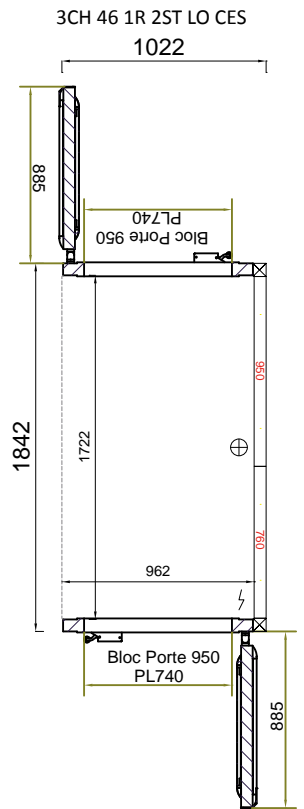
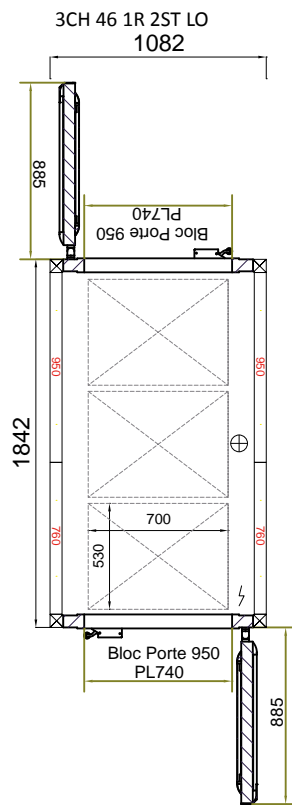
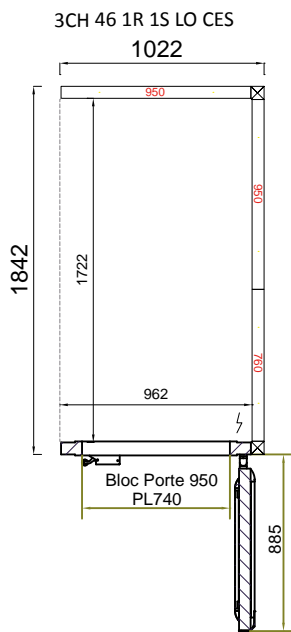
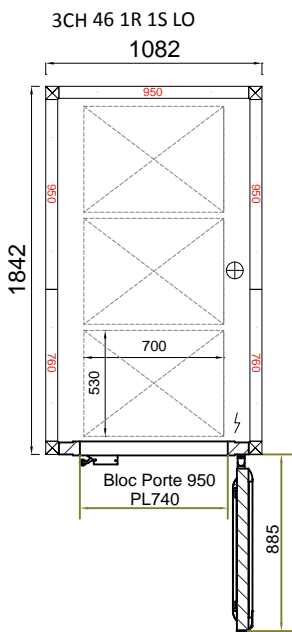

# Boreal Paneotrad 400x600 - 3 racks

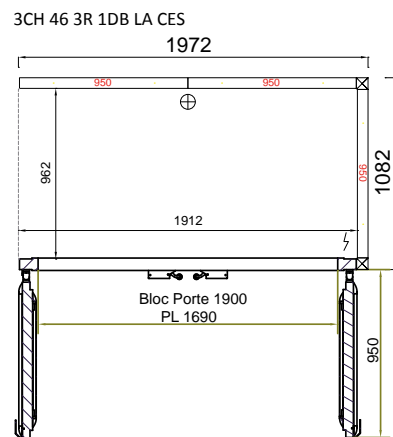
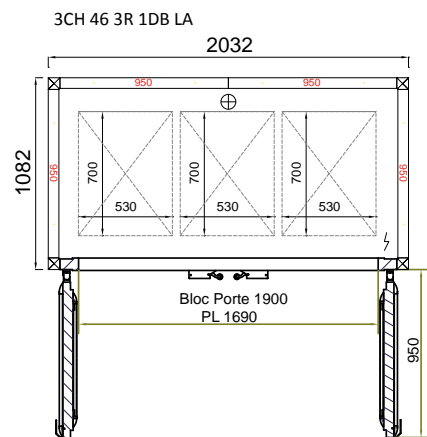
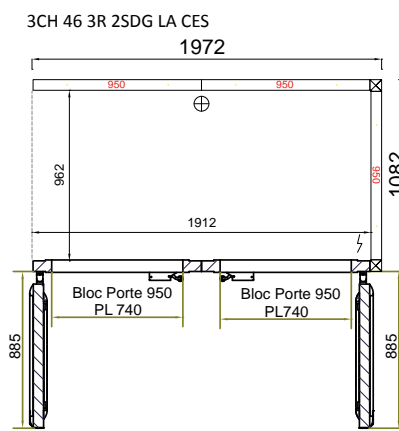
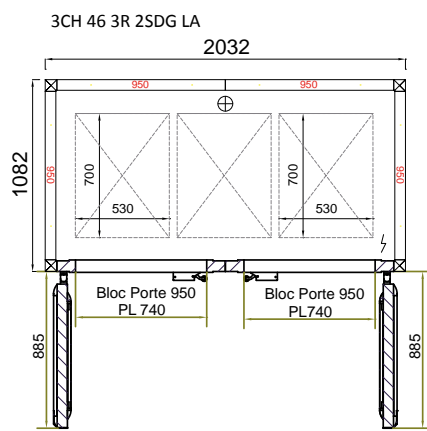
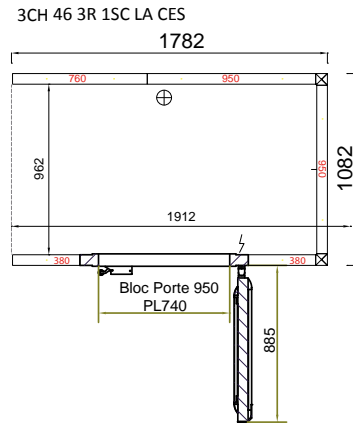
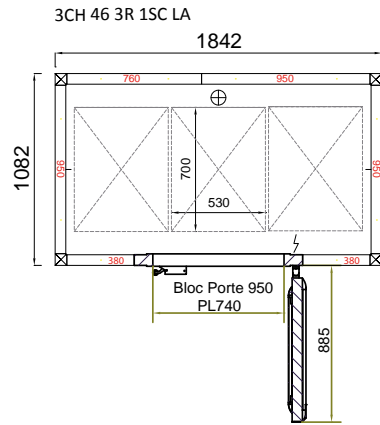



# Boreal Paneotrad 400x600 - 4 racks

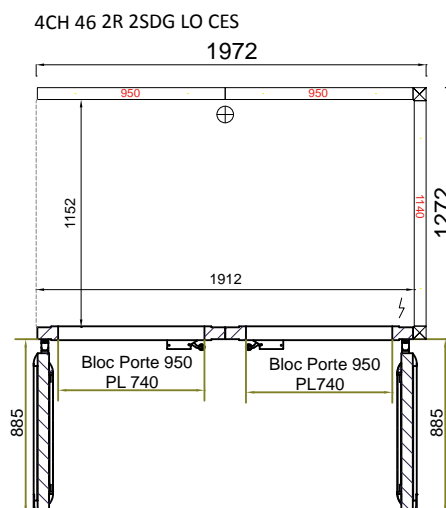
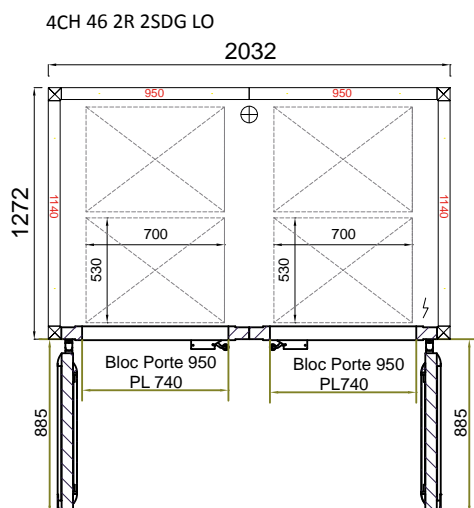
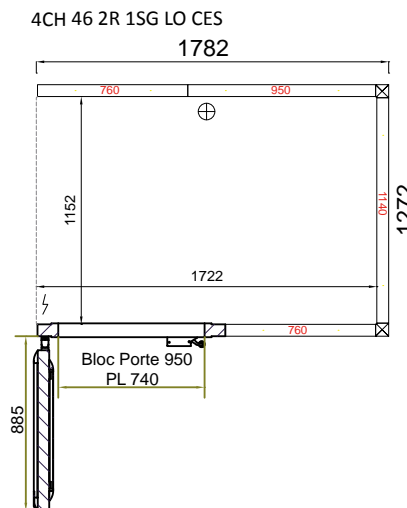
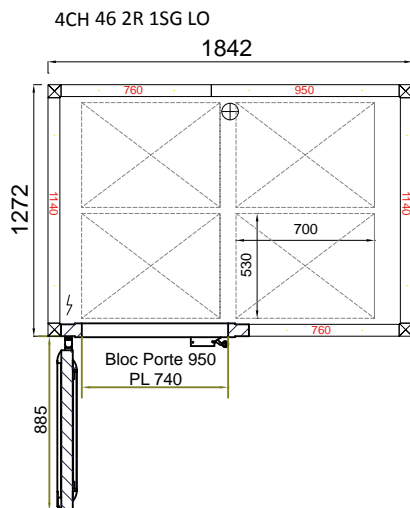
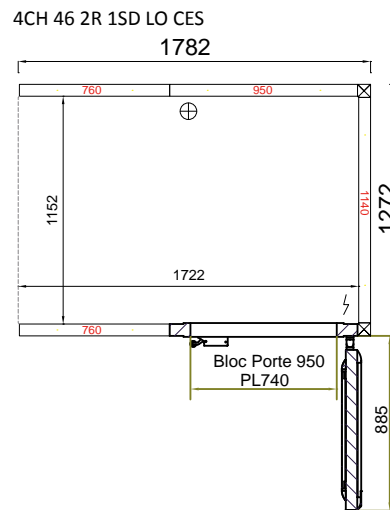
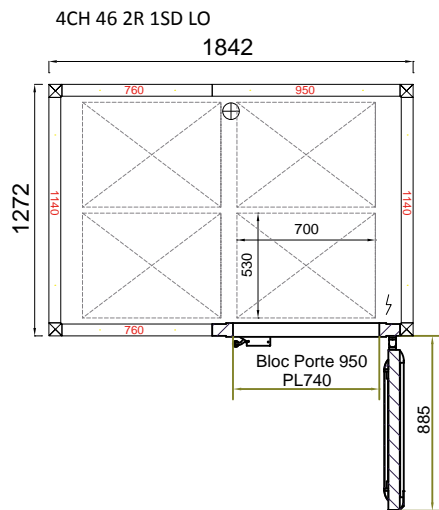

# Boreal Paneotrad 400x600 - 4 racks

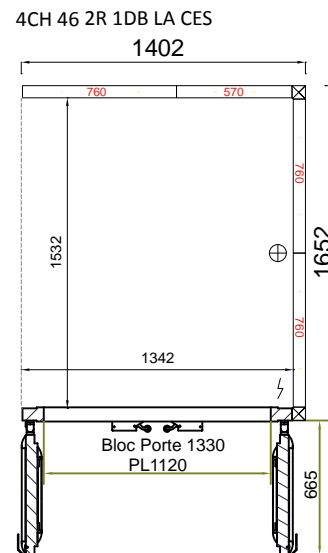
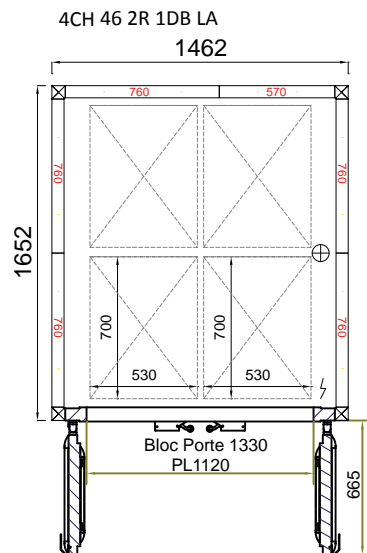
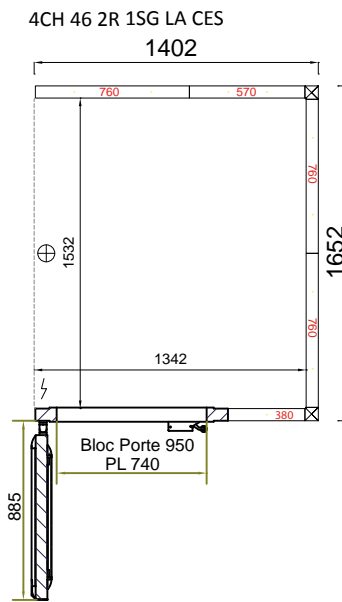
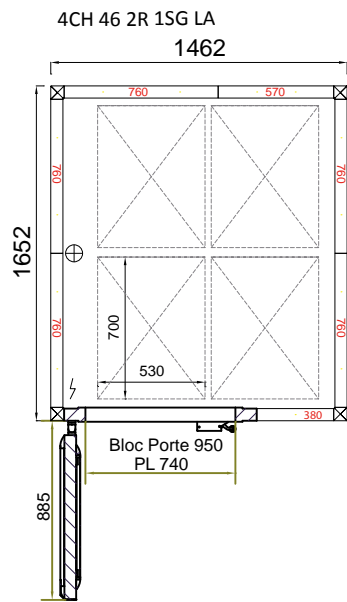
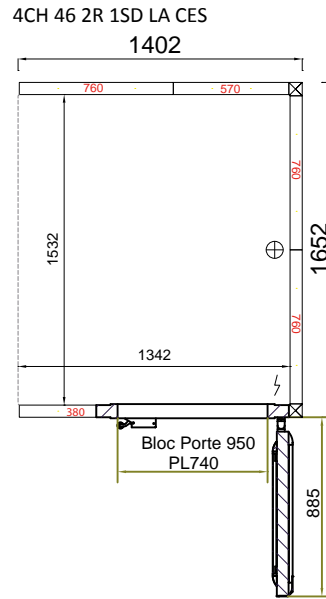
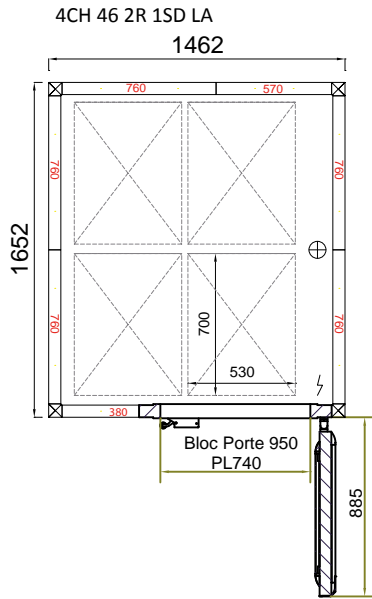

# Boreal Paneotrad 400x600 - 4 racks

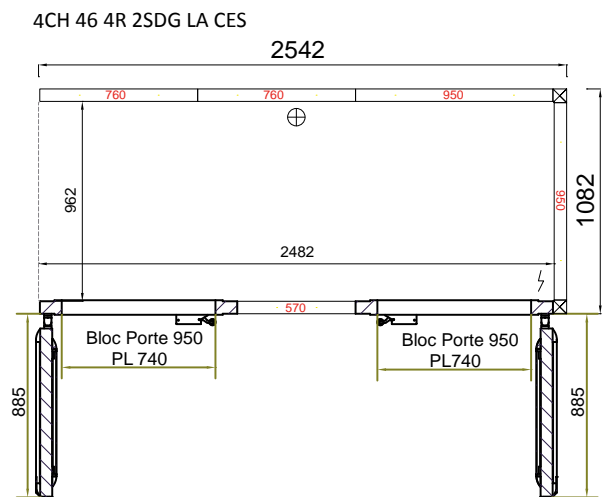
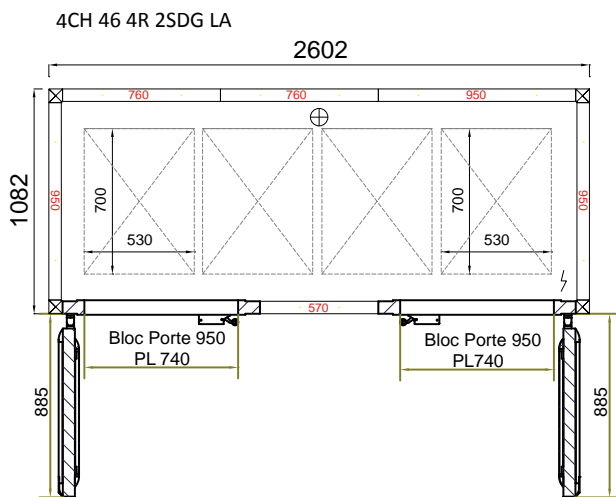
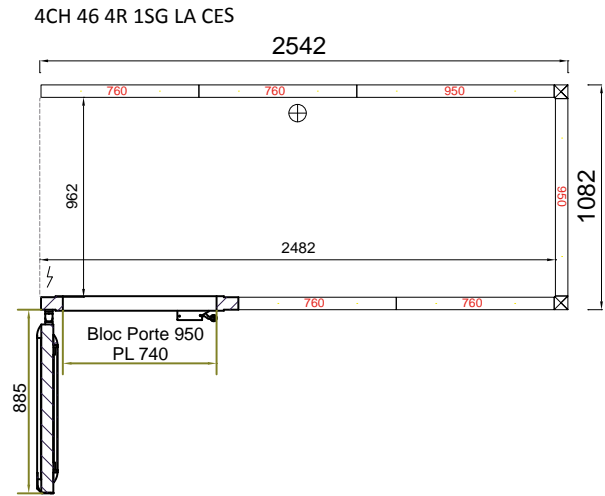
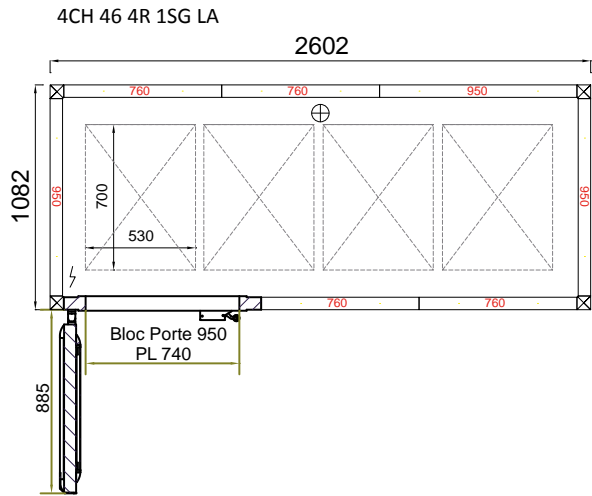

# Boreal Paneotrad 400x600 - 4 racks

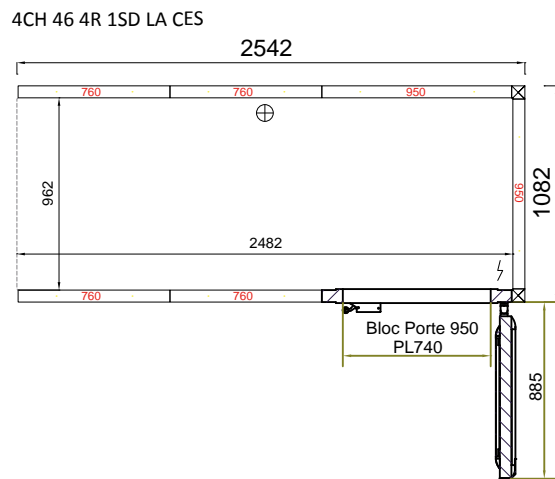
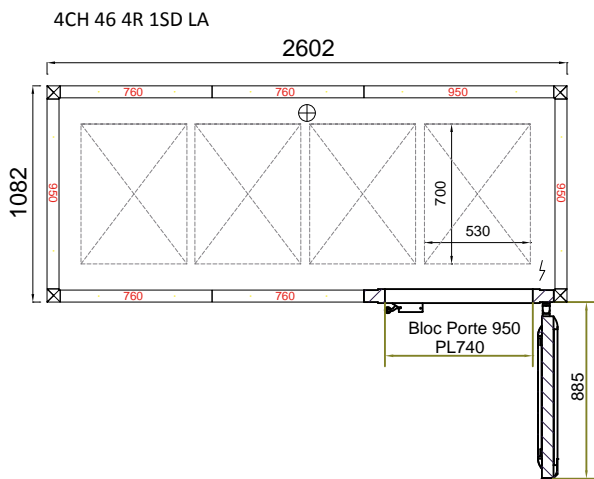
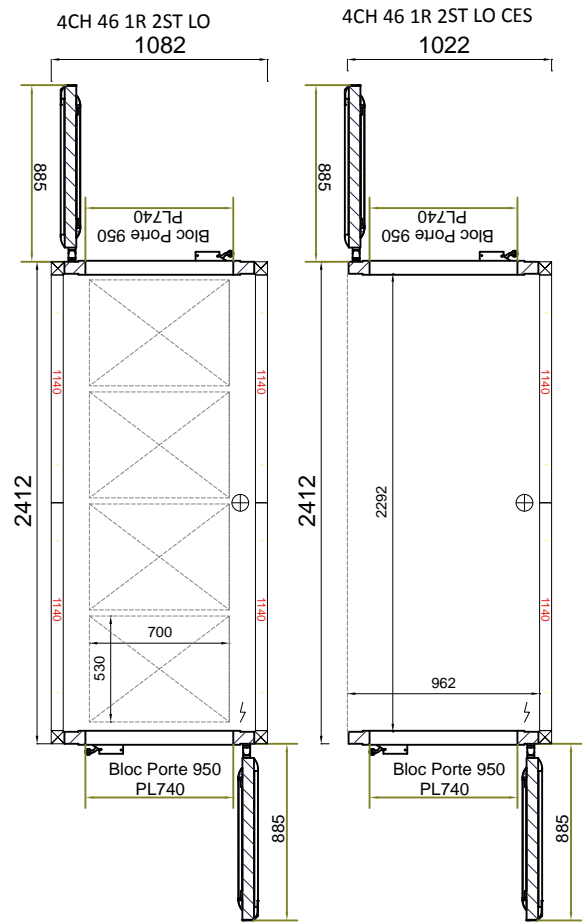
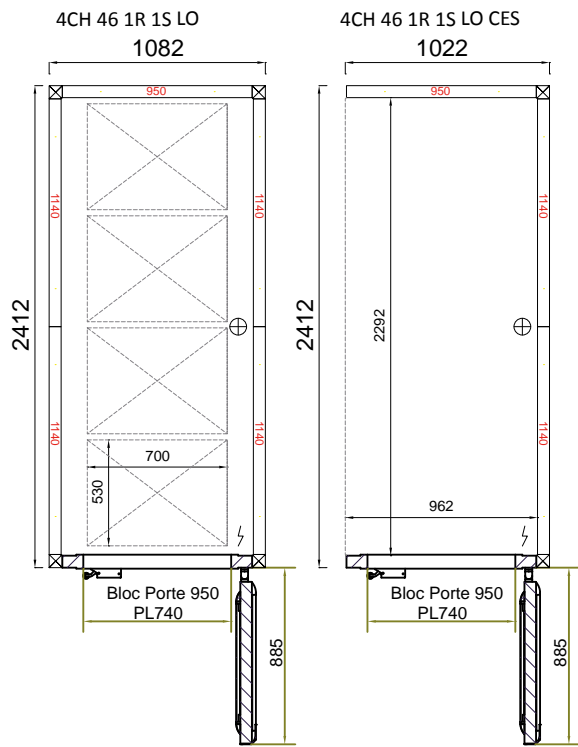

# Boreal Paneotrad 400x600 - 6 racks

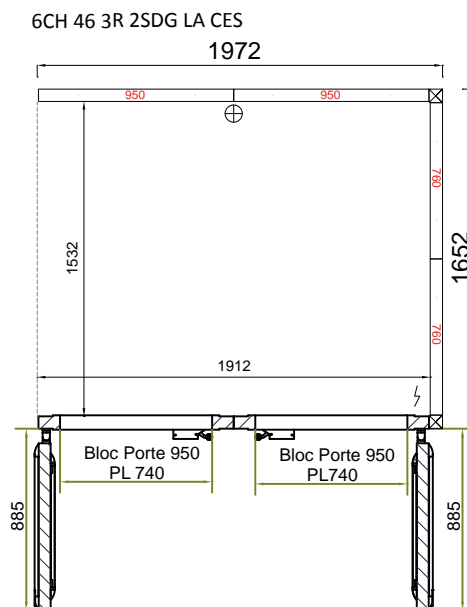
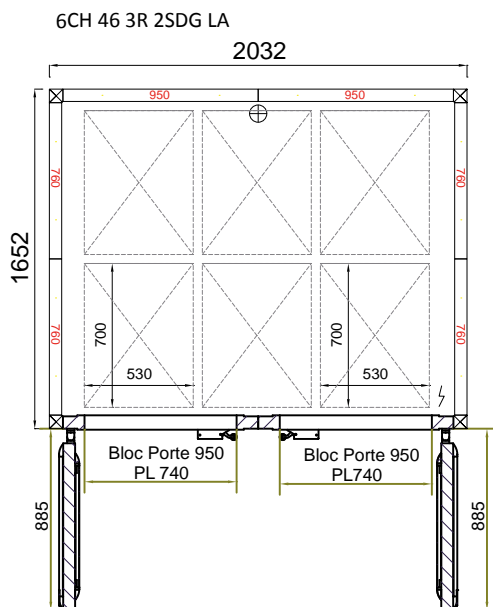
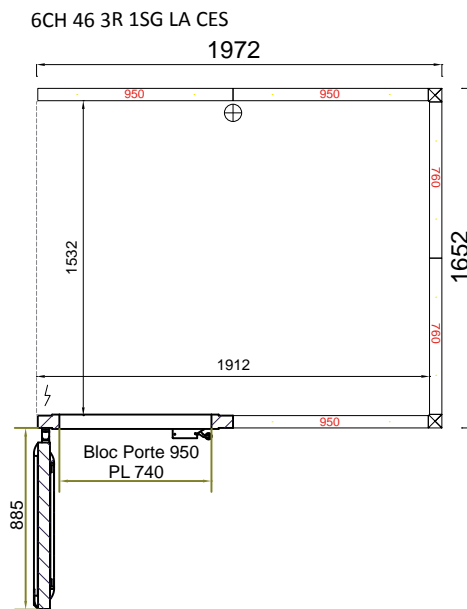
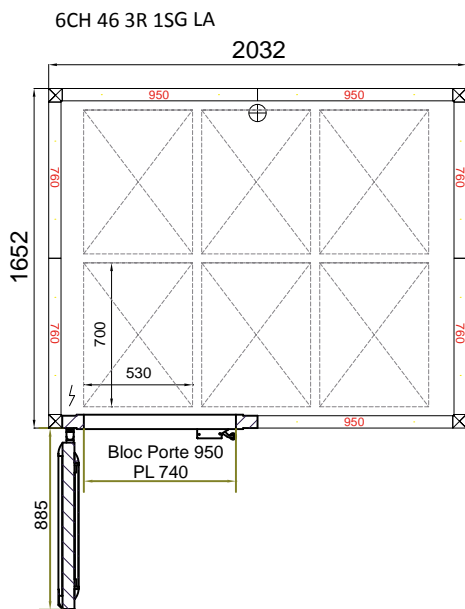
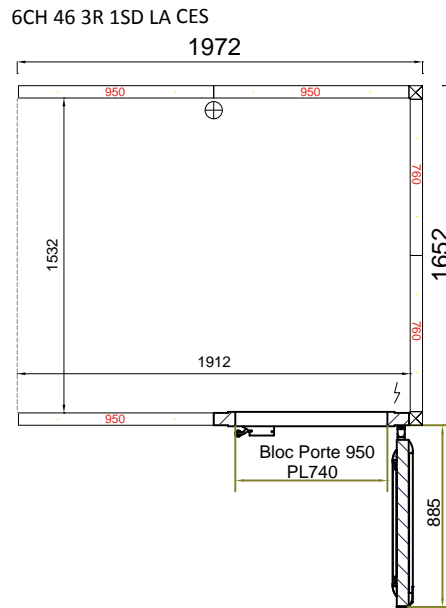
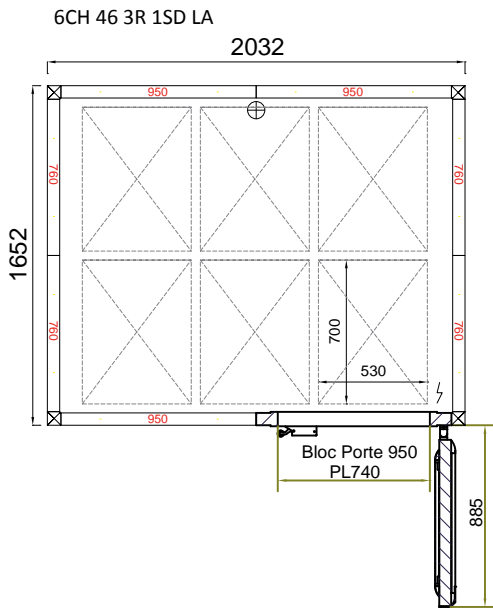

# Boreal Paneotrad 400x600 - 6 racks

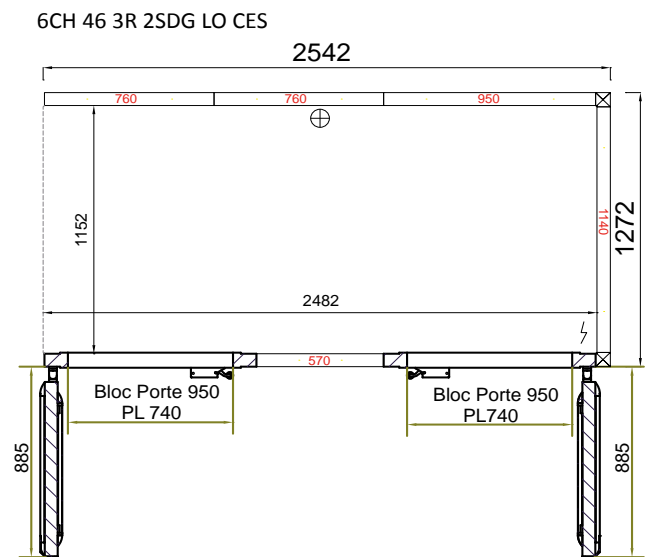
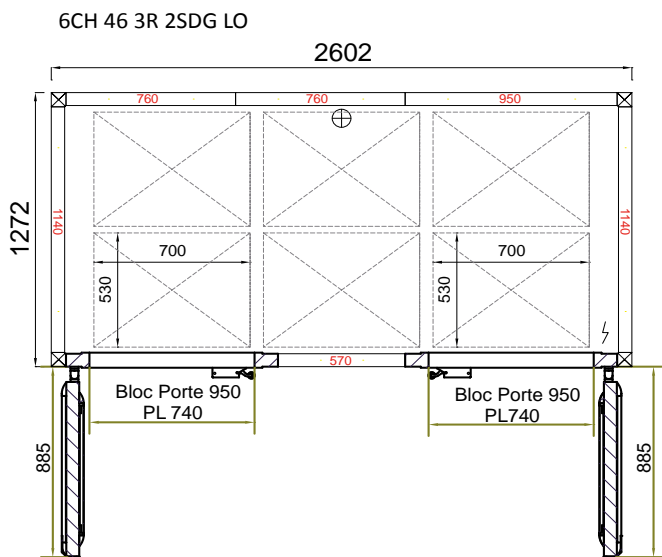
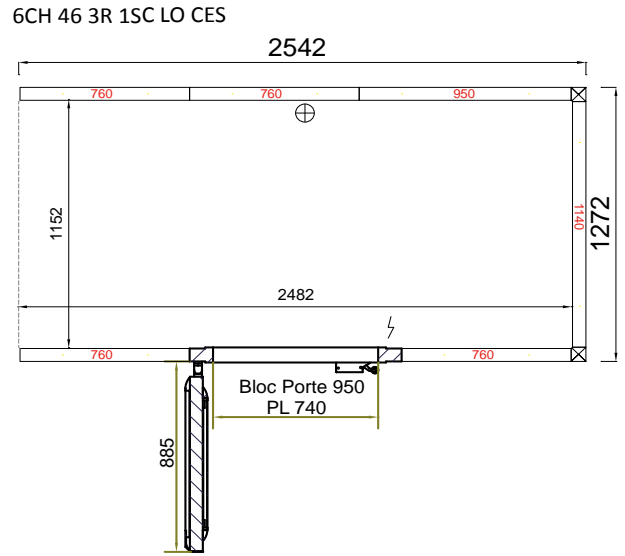
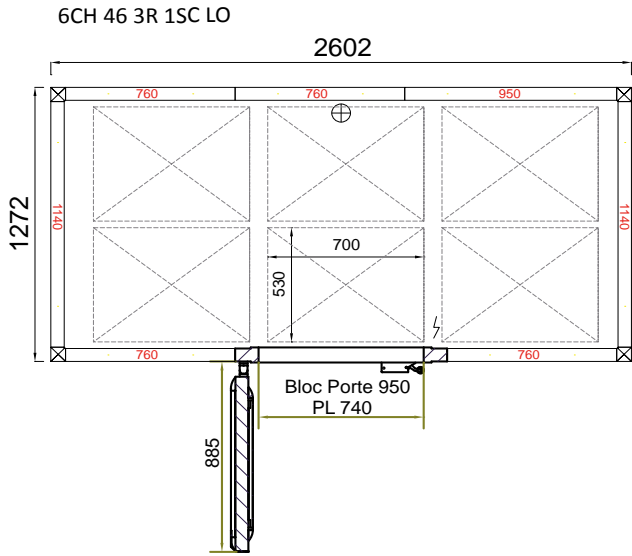

# Boreal Paneotrad 400x600 - 6 racks

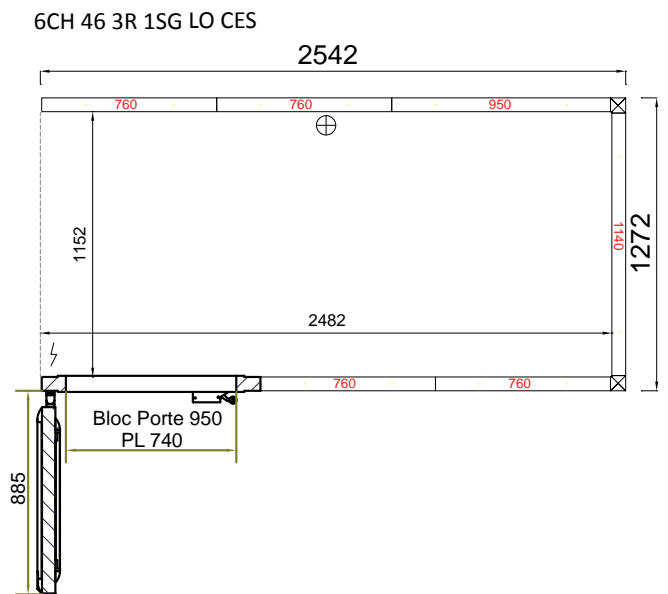
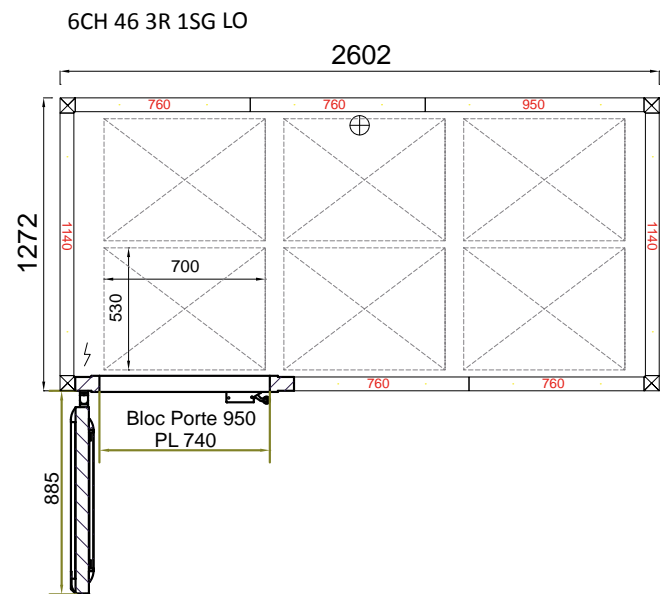
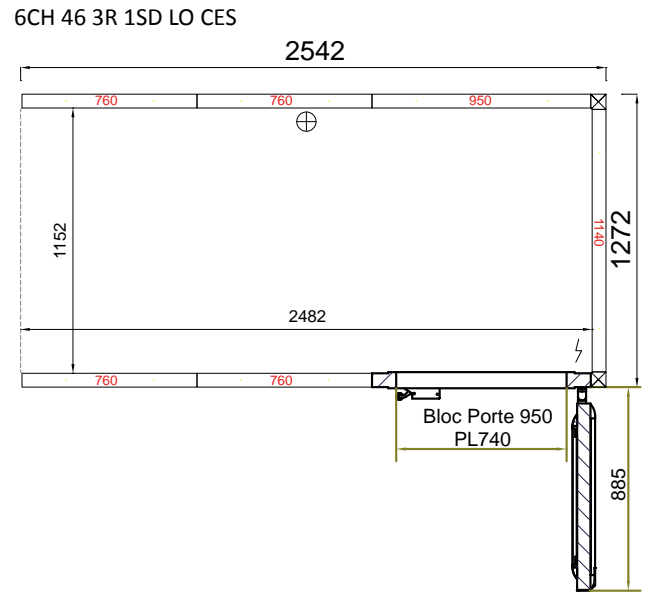
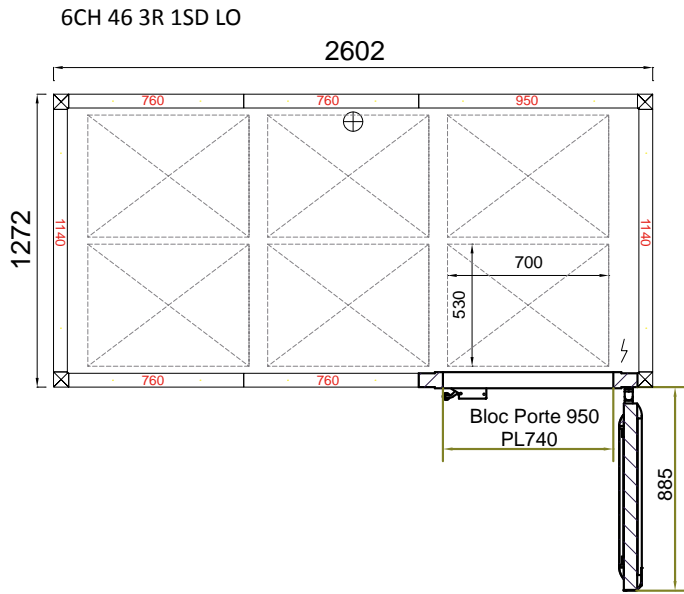

# Boreal Paneotrad 400x600 - 6 racks

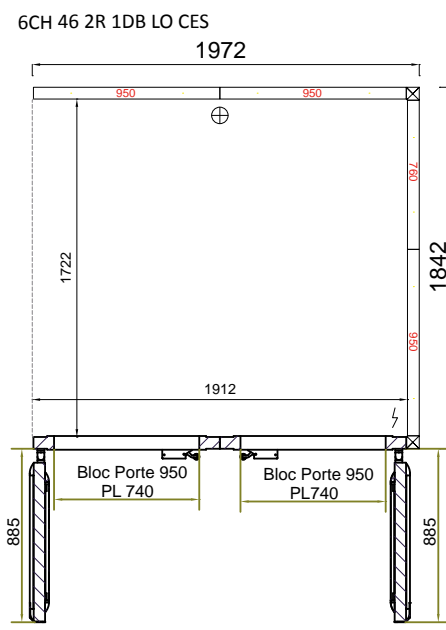
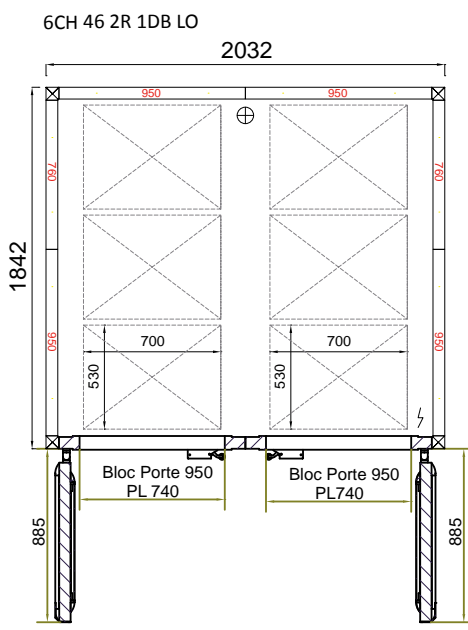
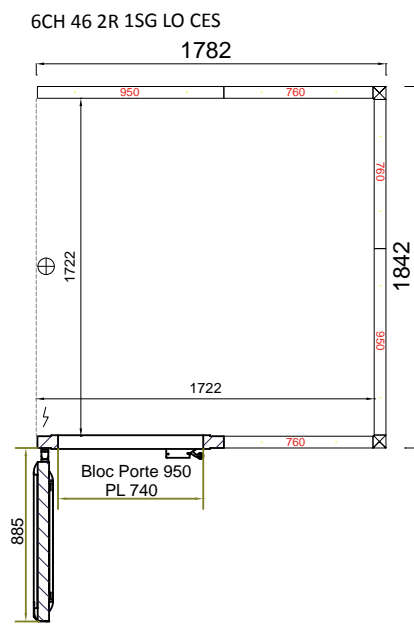
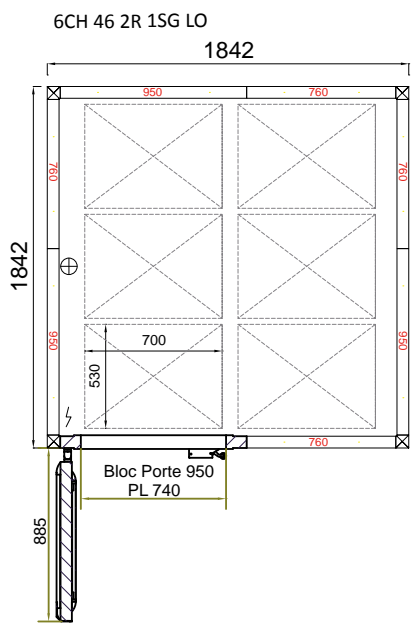
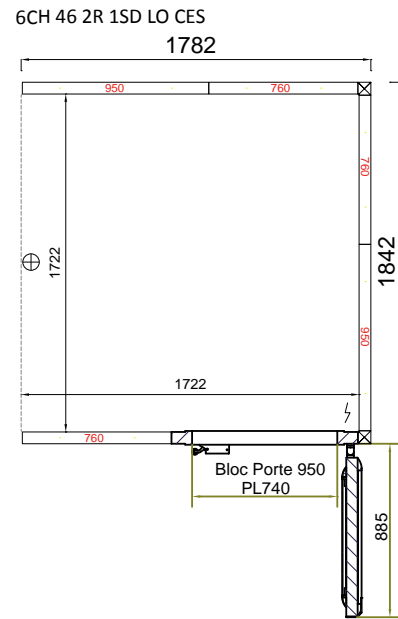
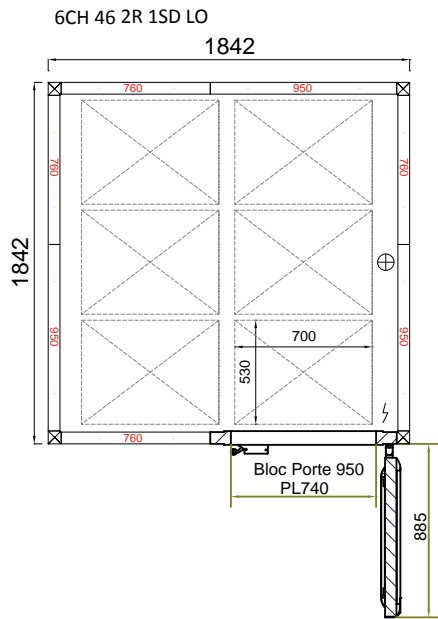



# Boreal Paneotrad 400x600 - 6 racks

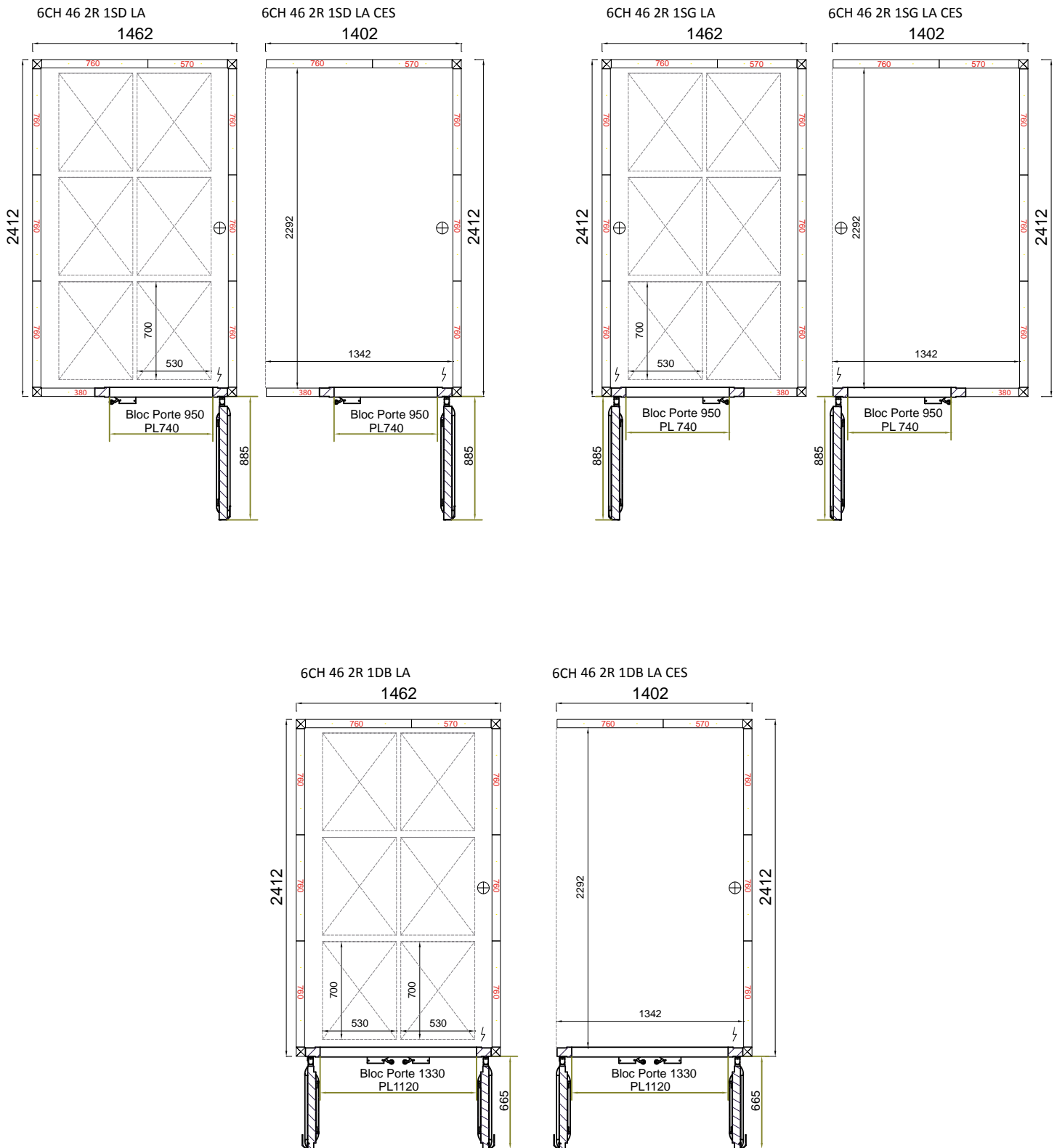

# Boreal Paneotrad 400x600 - 6 racks

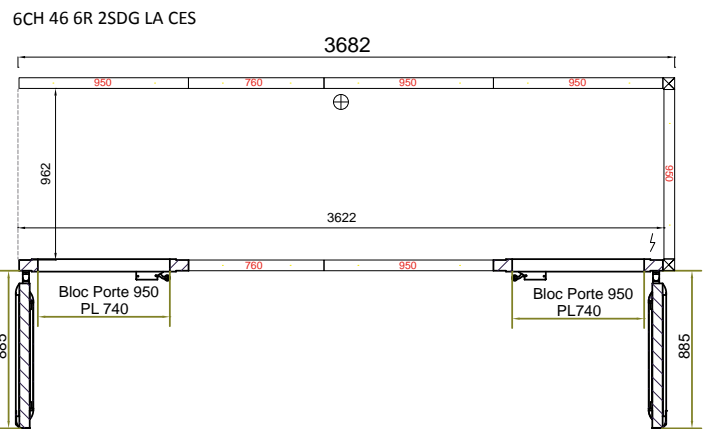
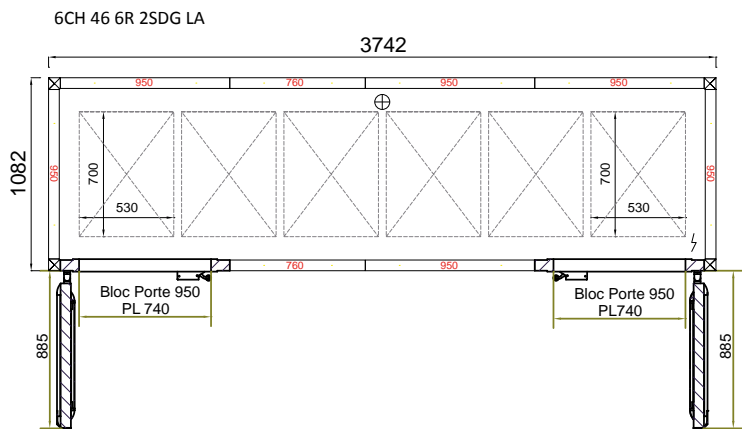
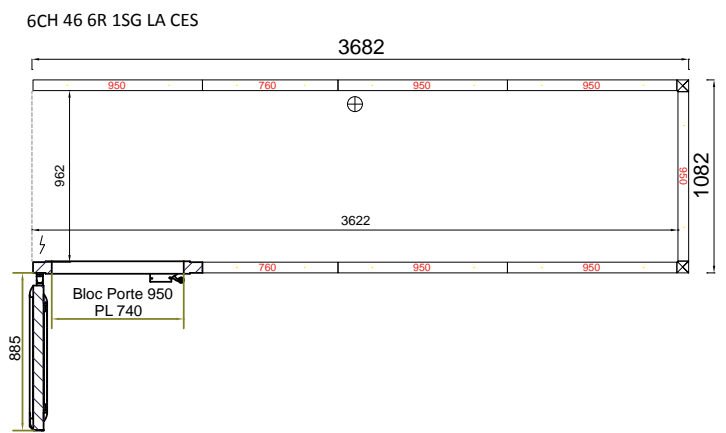
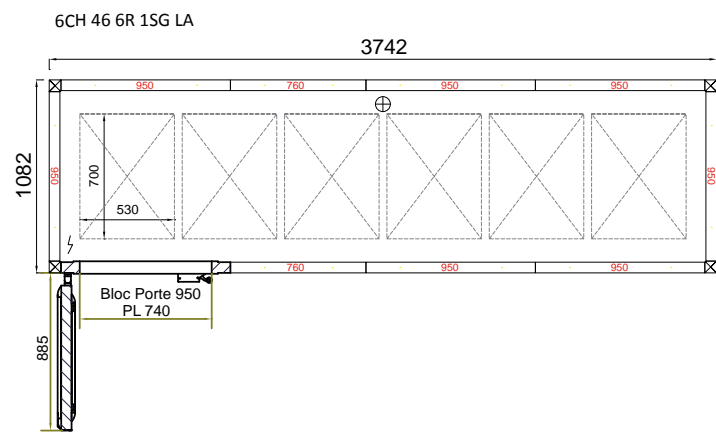
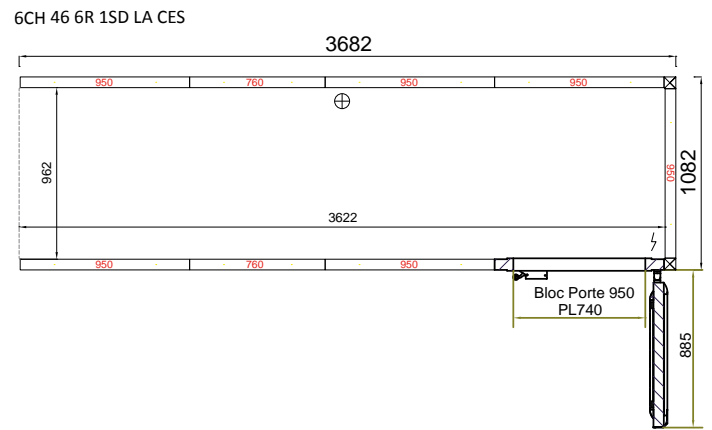
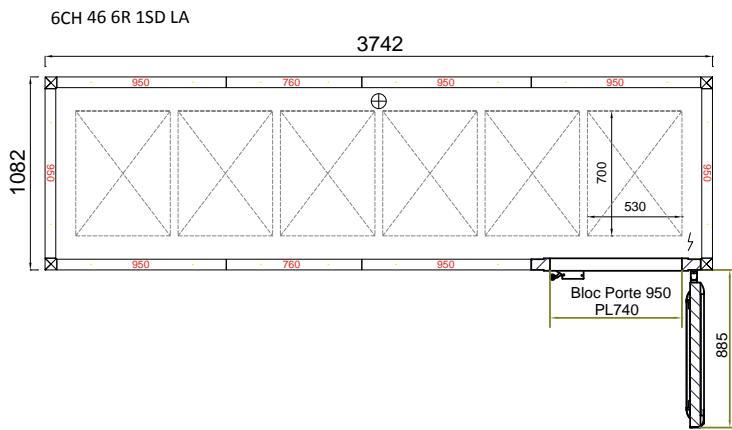

# Boreal Paneotrad 400x600 - 6 racks

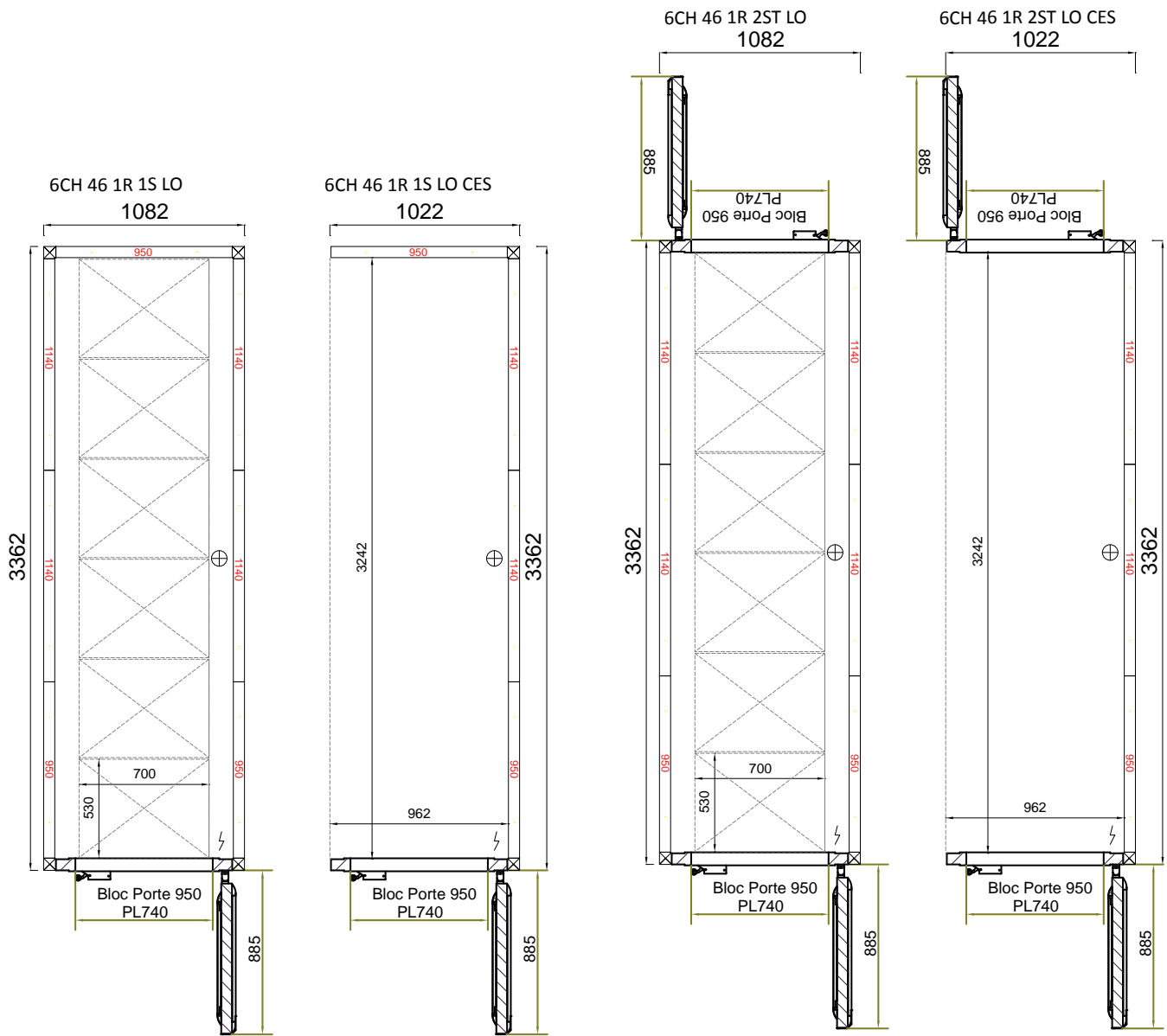

# Boreal Paneotrad 400x600 - 8 racks

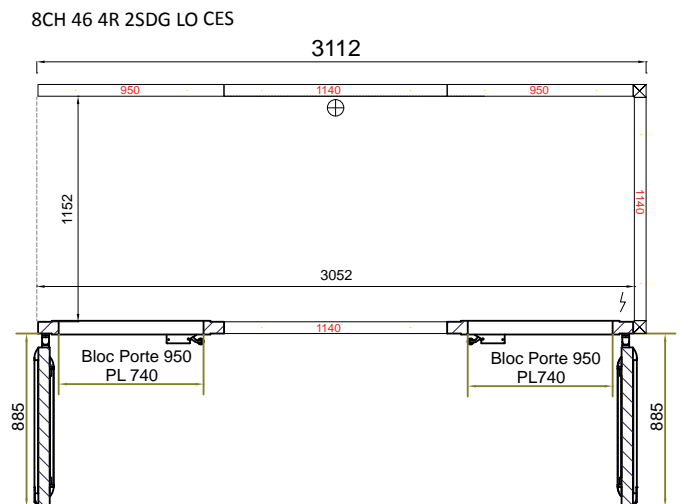
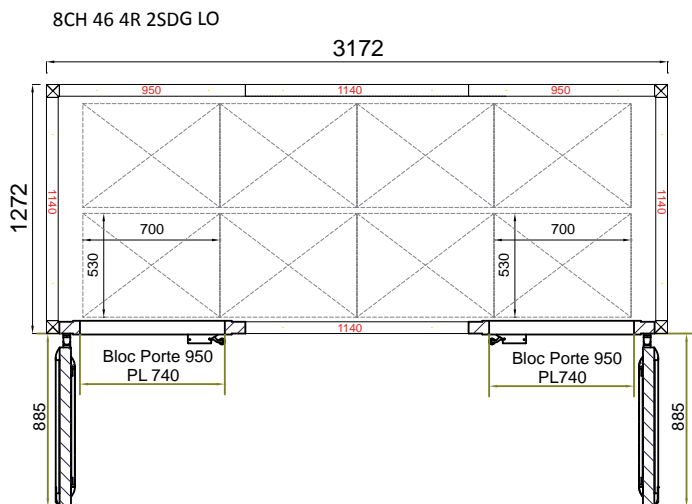
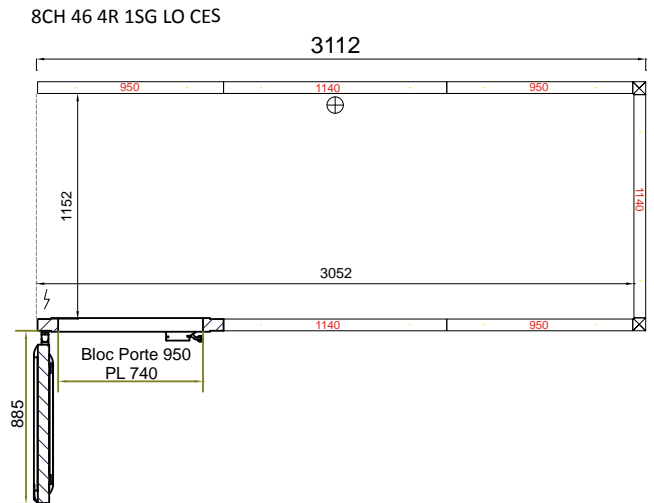
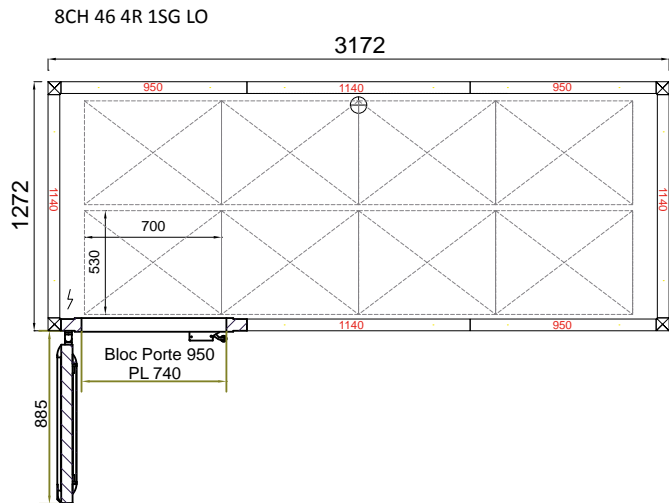
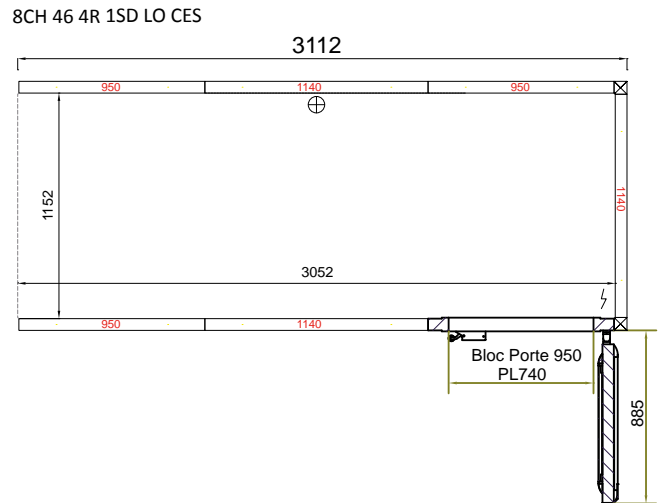
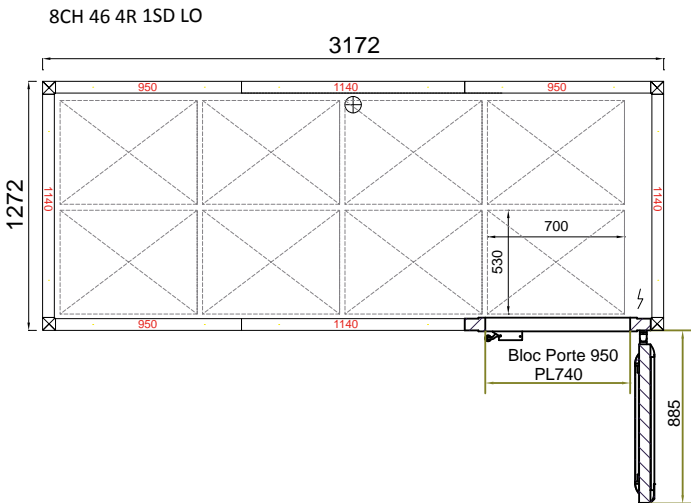

# Boreal Paneotrad 400x600 - 8 racks

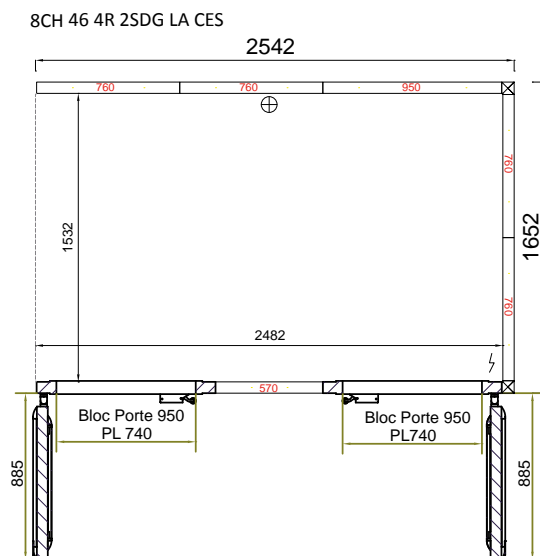
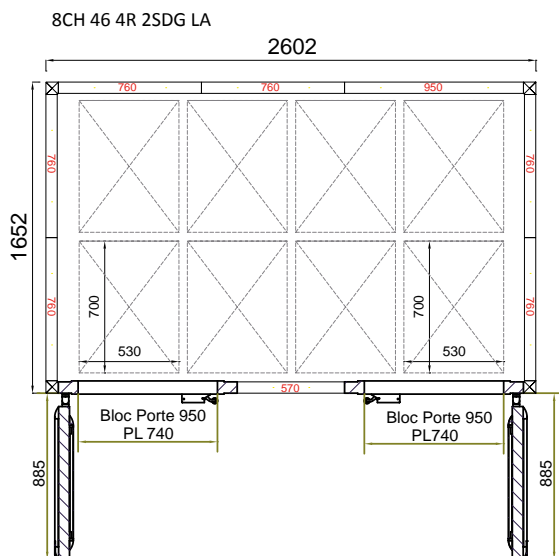
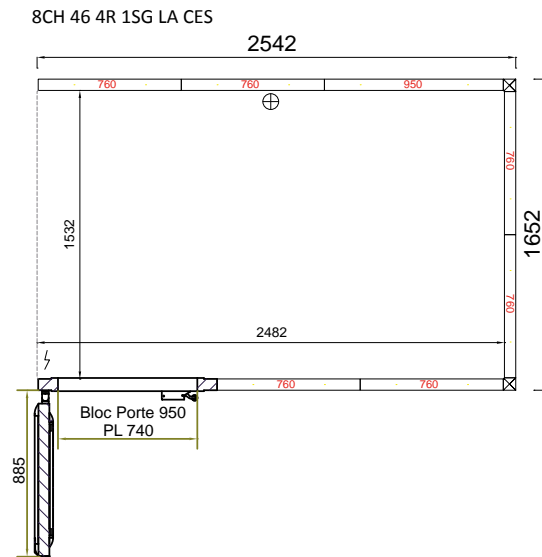
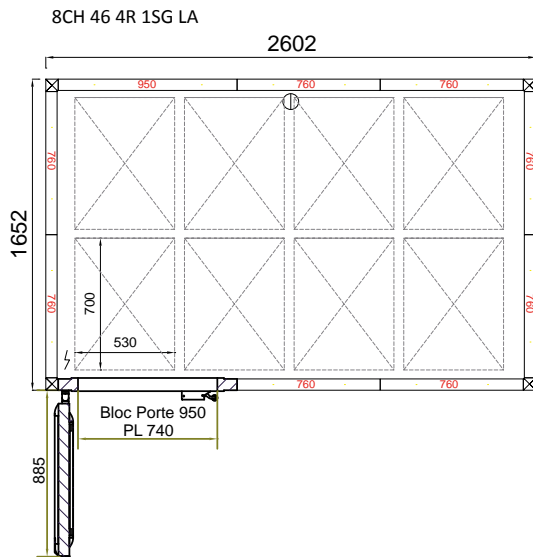
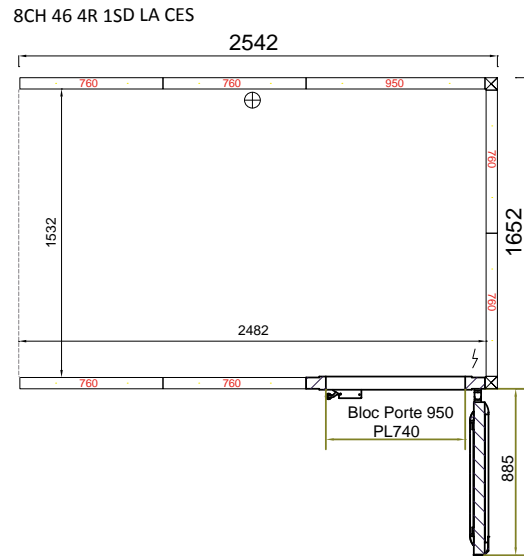
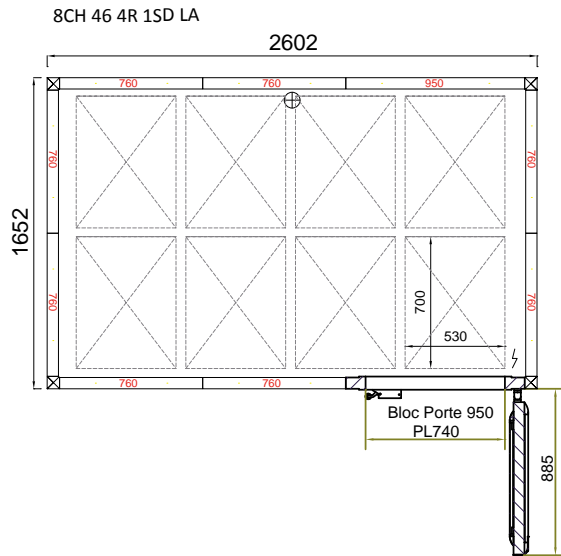

# Boreal Paneotrad 400x600 - 8 racks

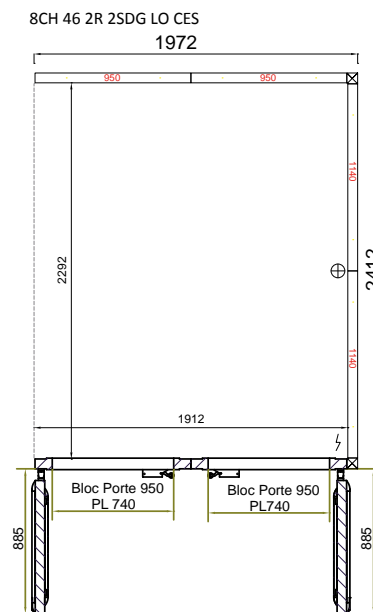
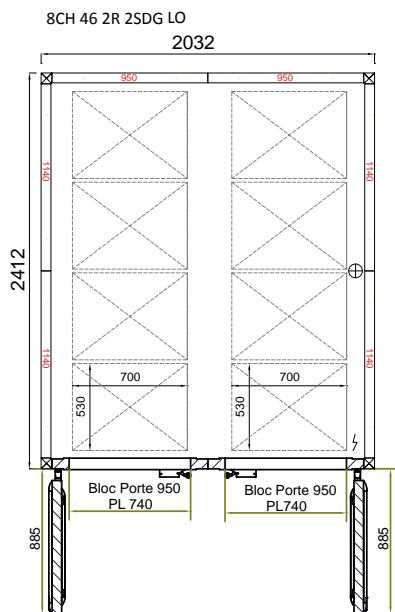
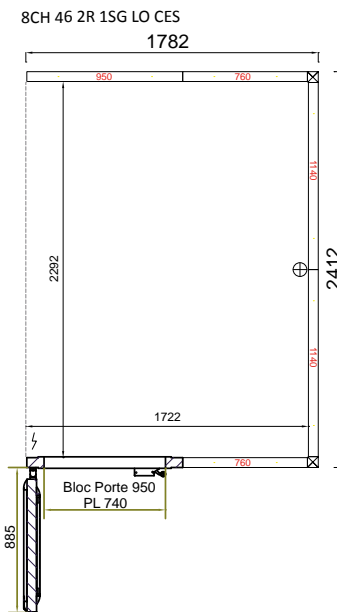
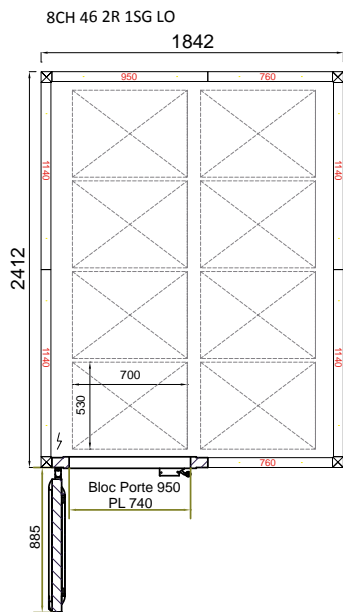
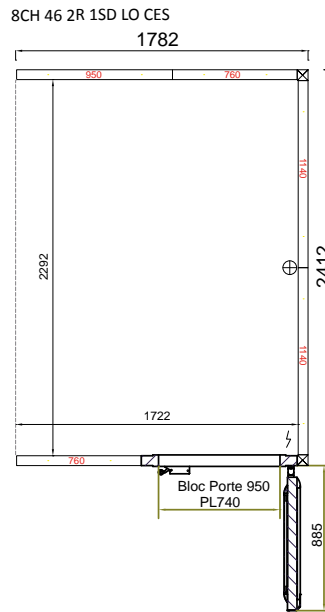
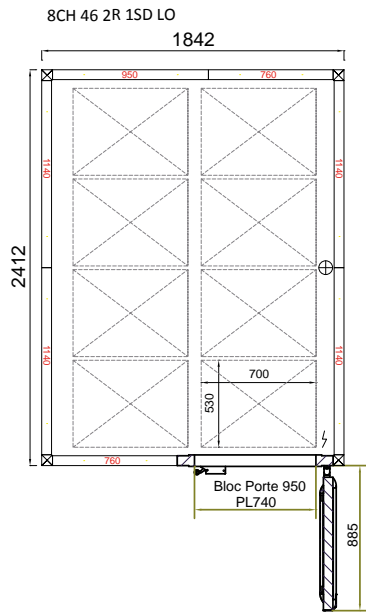

# Boreal Paneotrad 400x600 - 8 racks

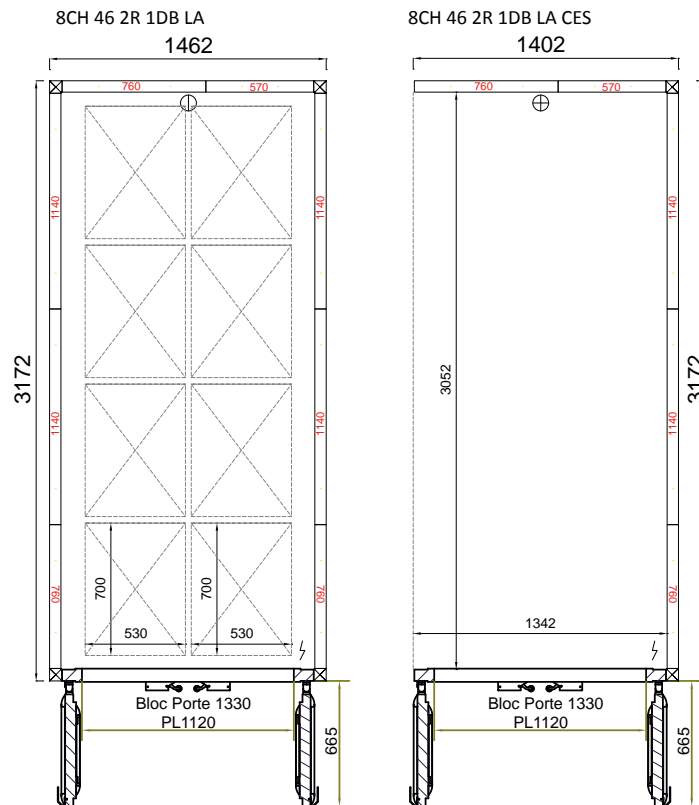
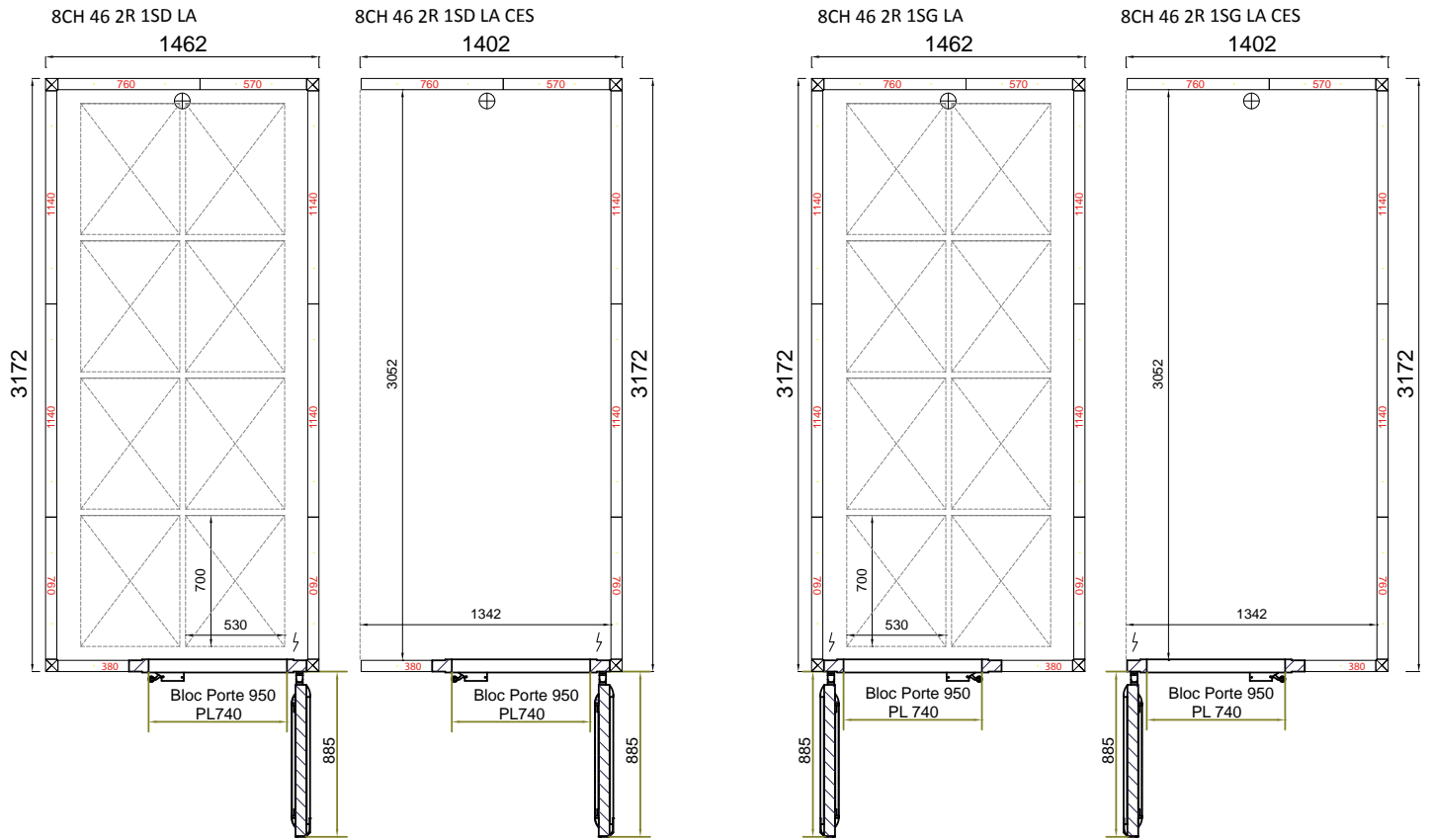

# Boreal Paneotrad 400x600 - 8 racks

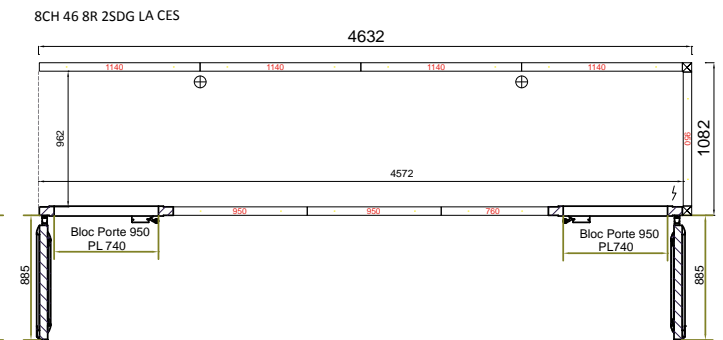
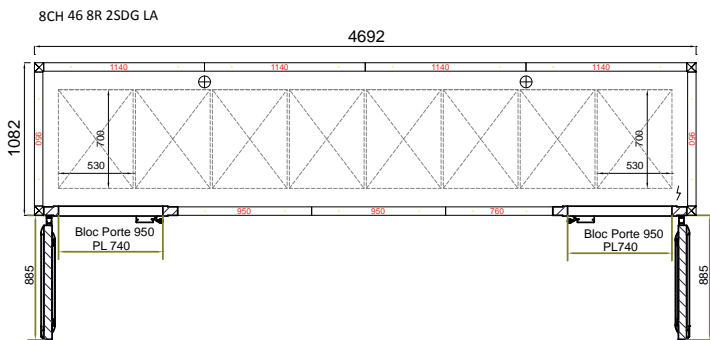
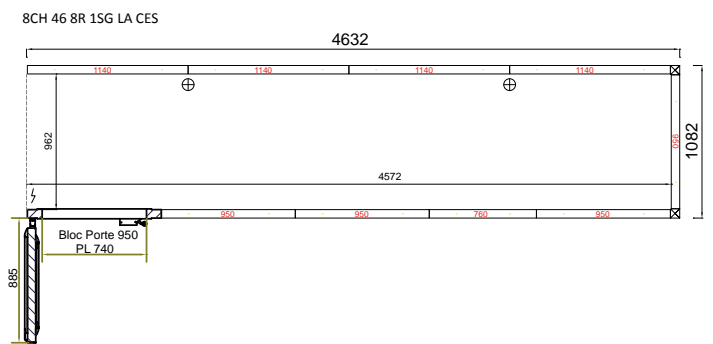
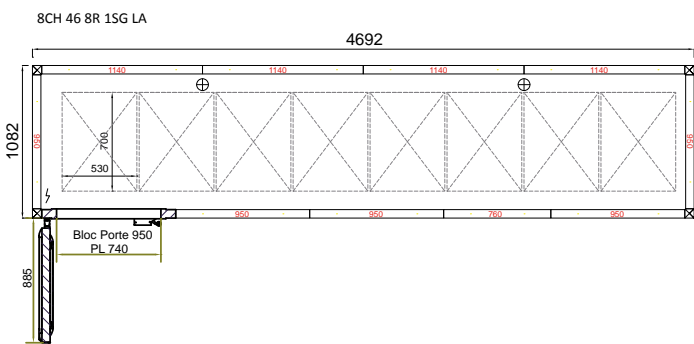
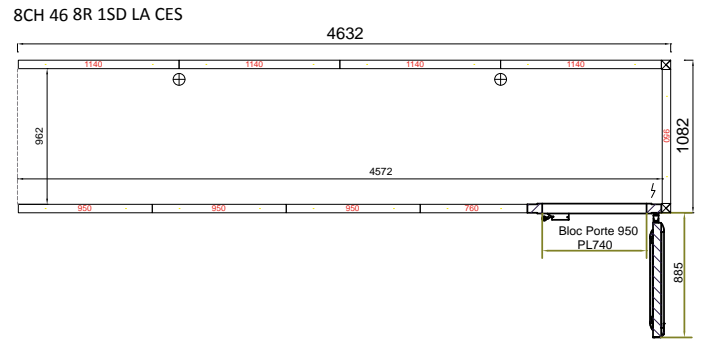
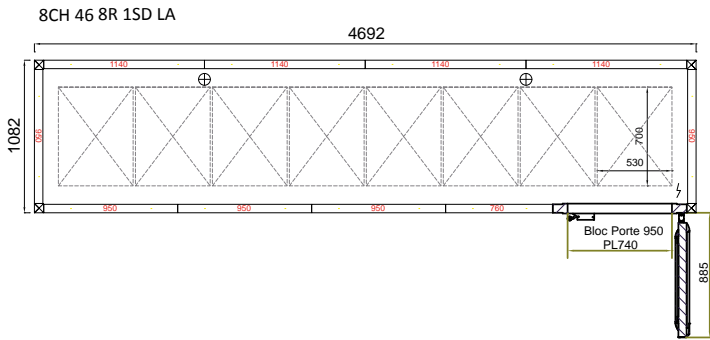



# Boreal Paneotrad 400x600 - 8 racks

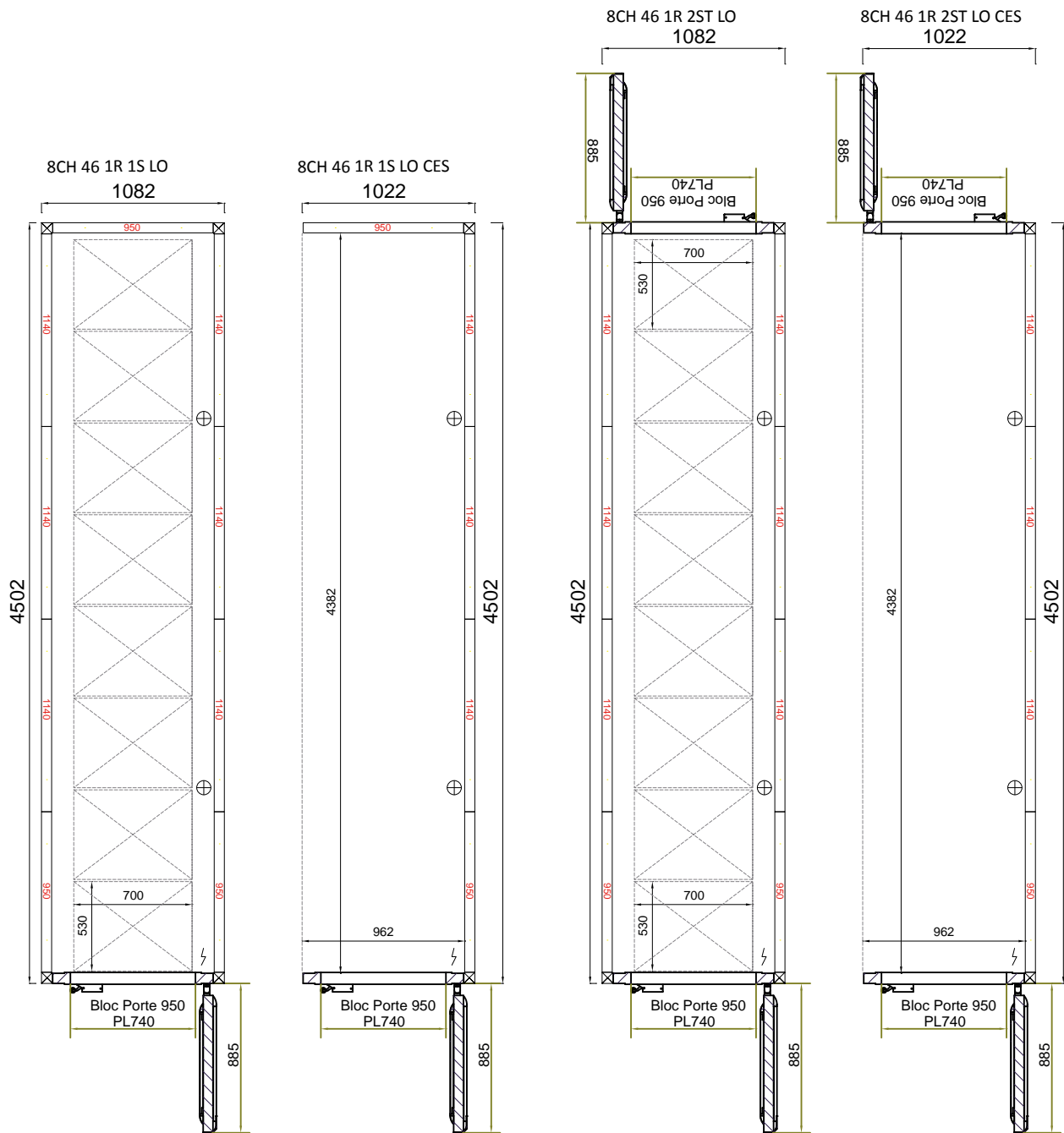

# Boreal Paneotrad 600X800 - 1 rack

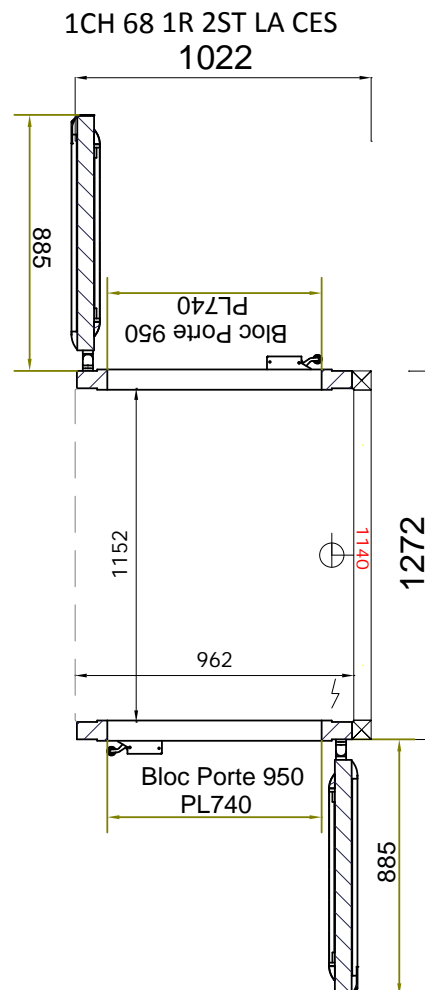
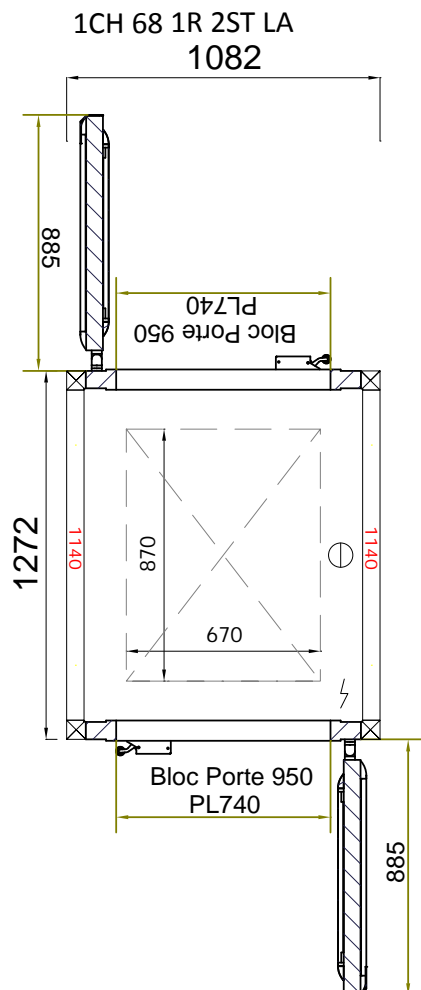
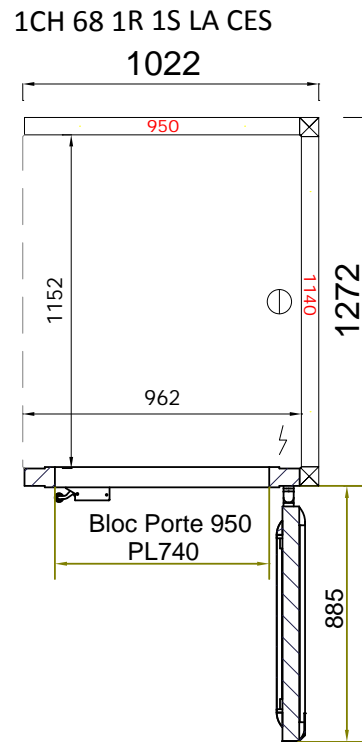
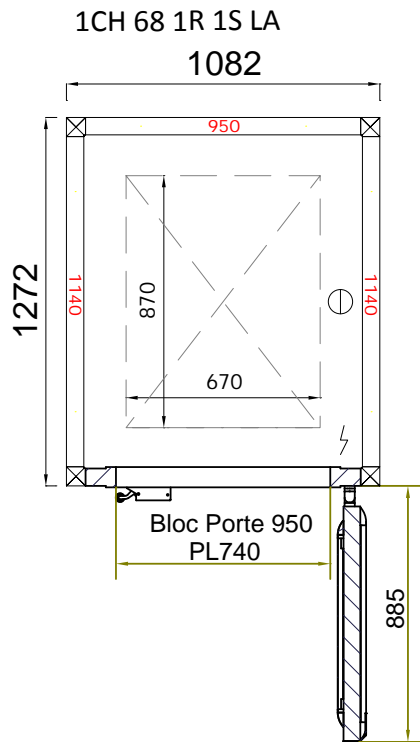

# Boreal Paneotrad 600x800 - 1 rack

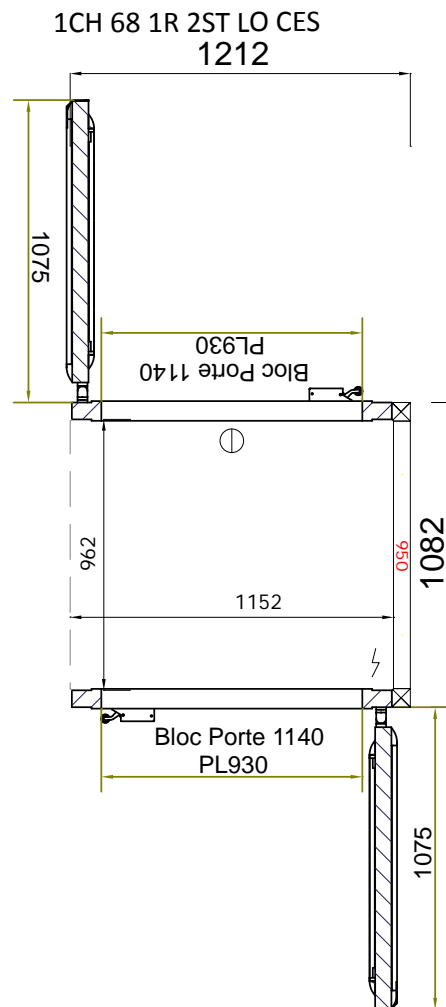
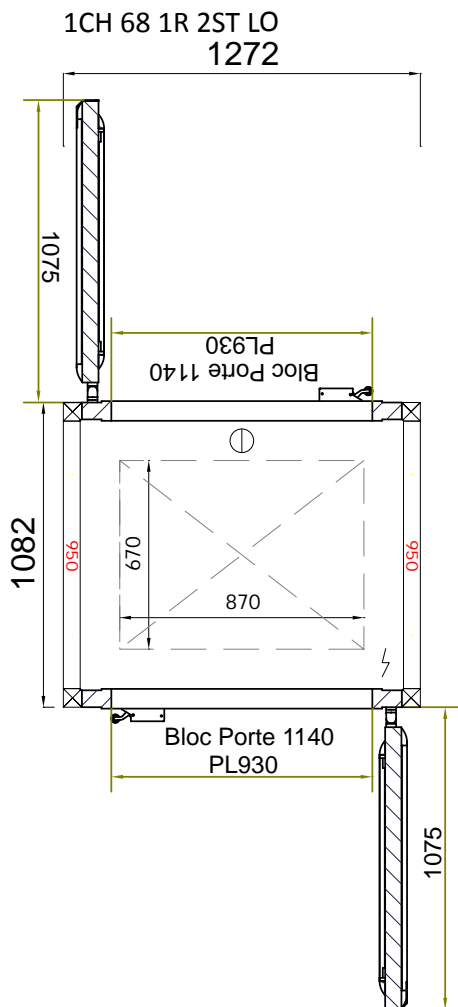
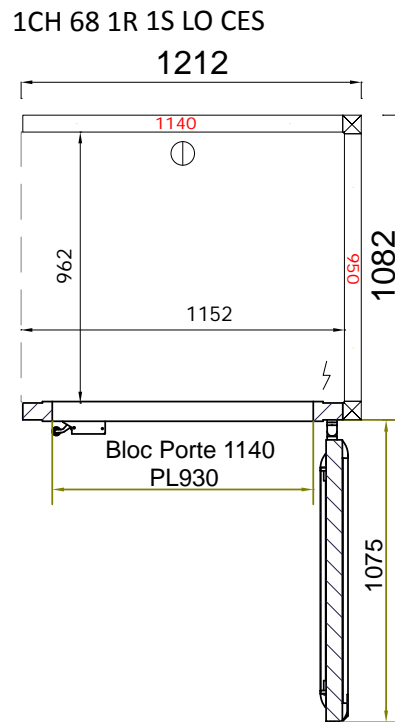
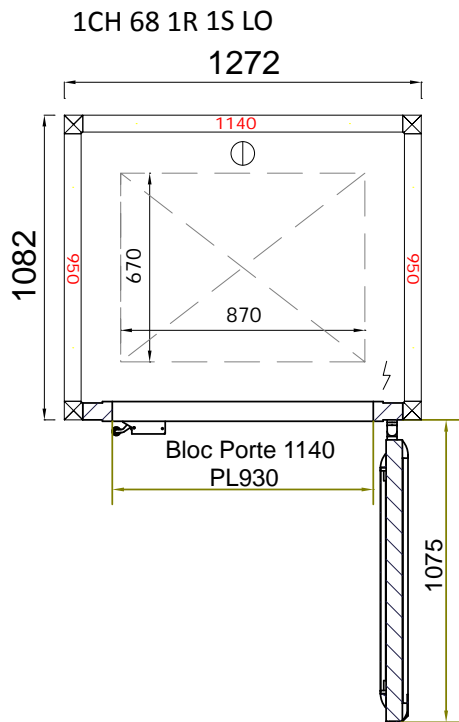

# Boreal Paneotrad 600x800 - 2 racks

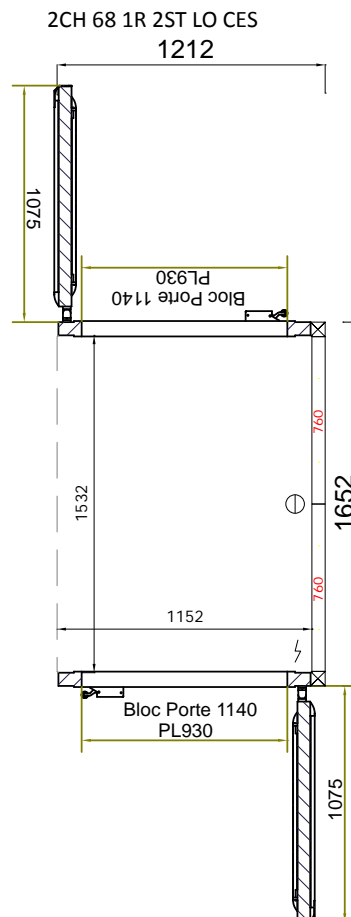
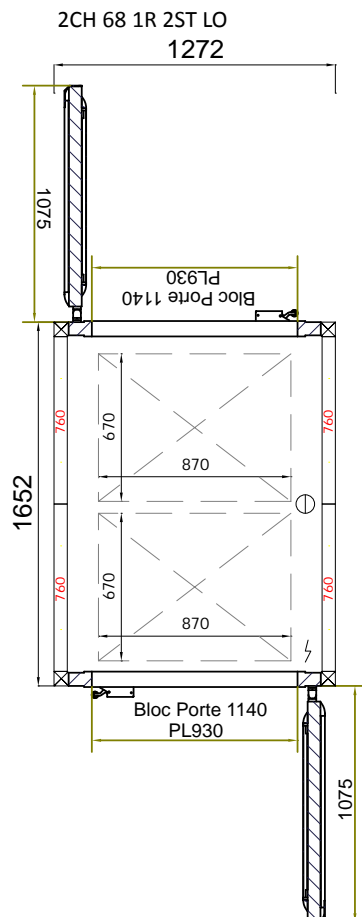
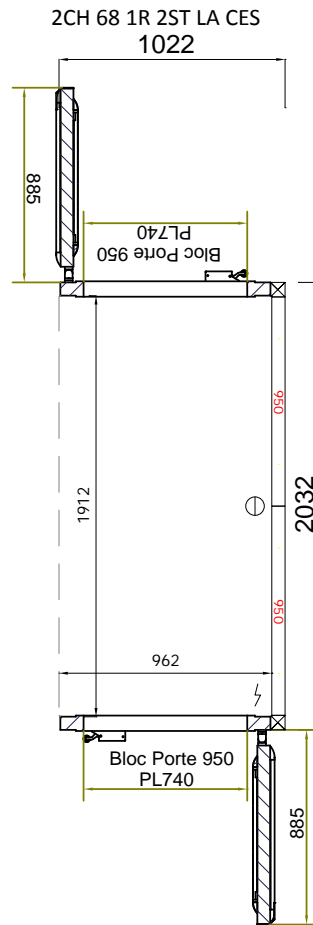
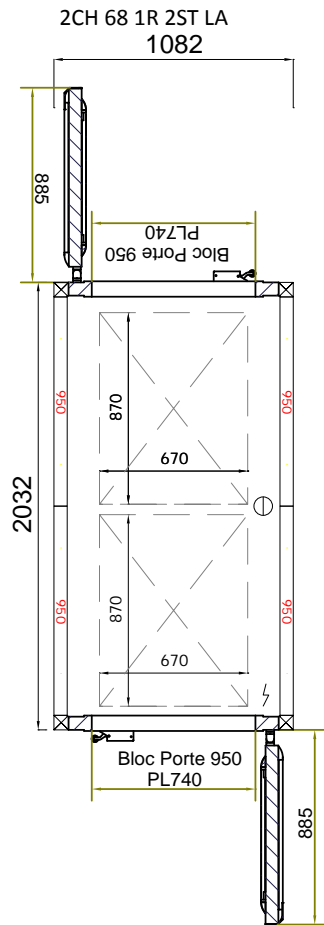

# Boreal Paneotrad 600x800 - 2 racks

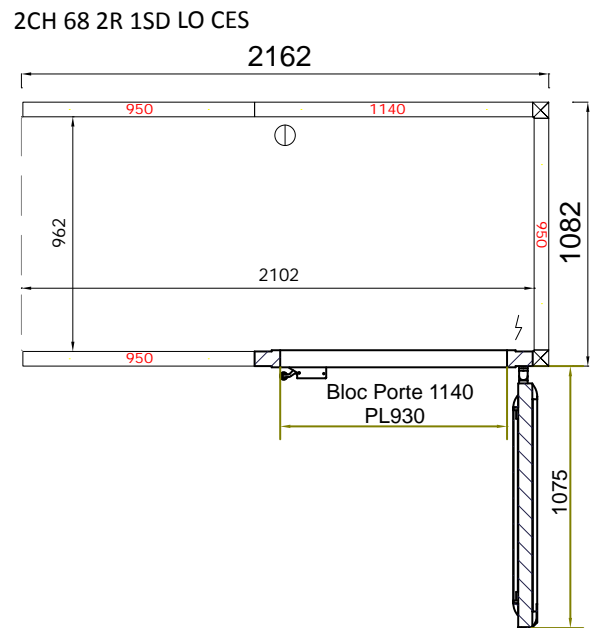
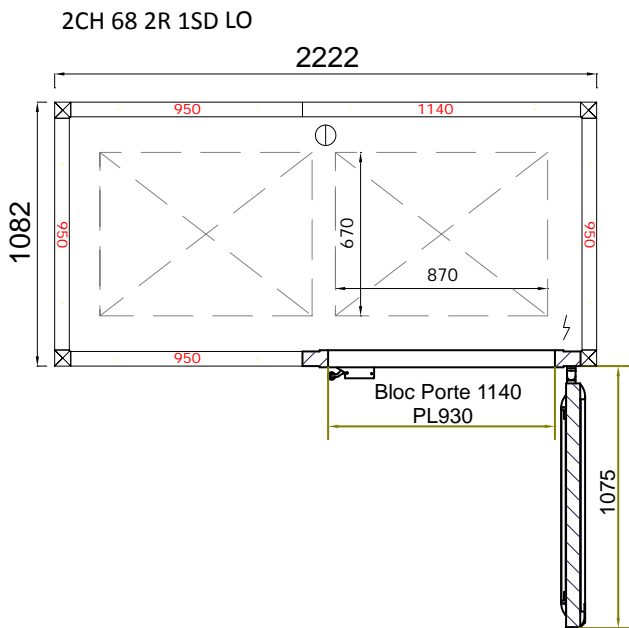
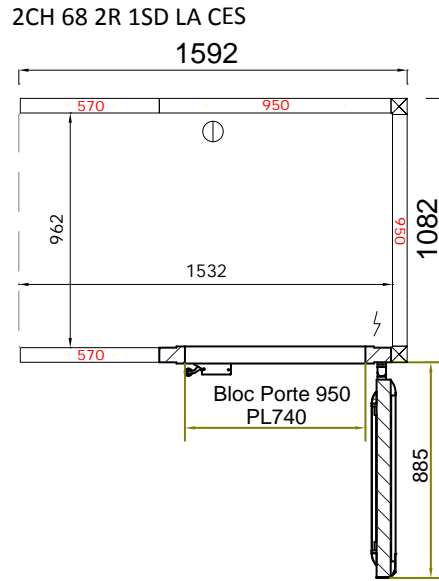
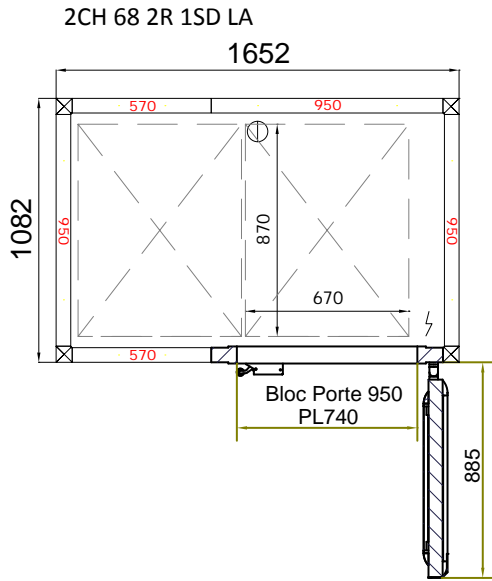

# Boreal Paneotrad 600x800 - 2 racks

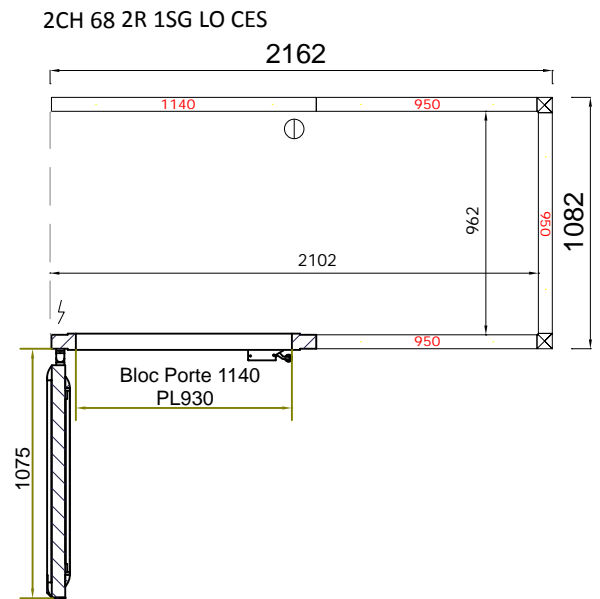
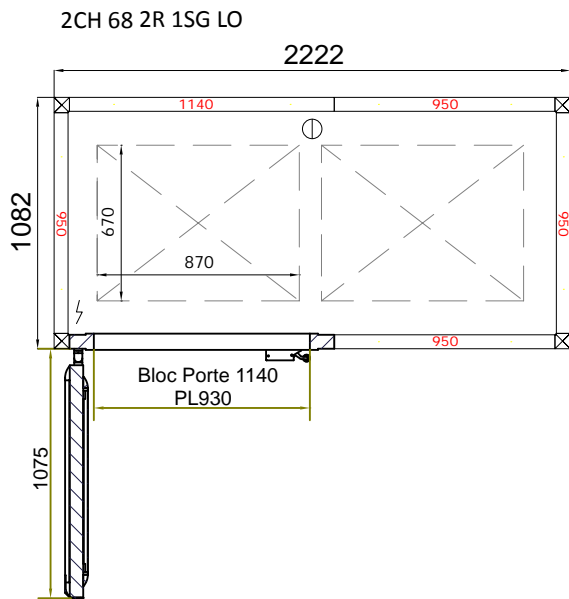
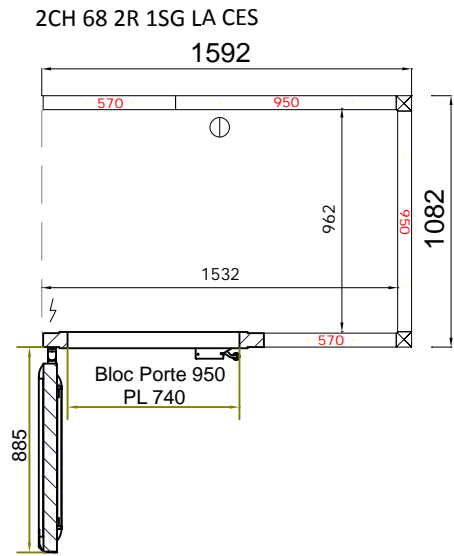
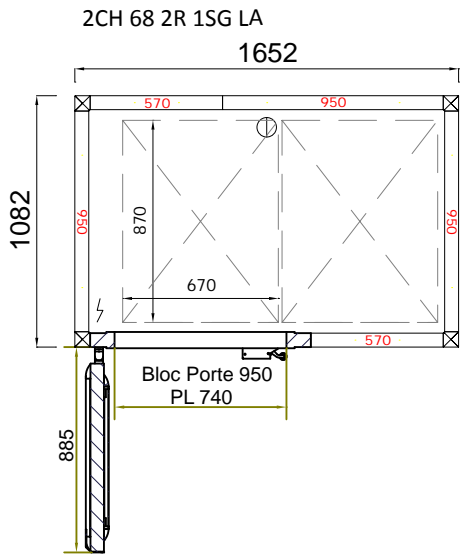

# Boreal Paneotrad 600x800 - 2 racks

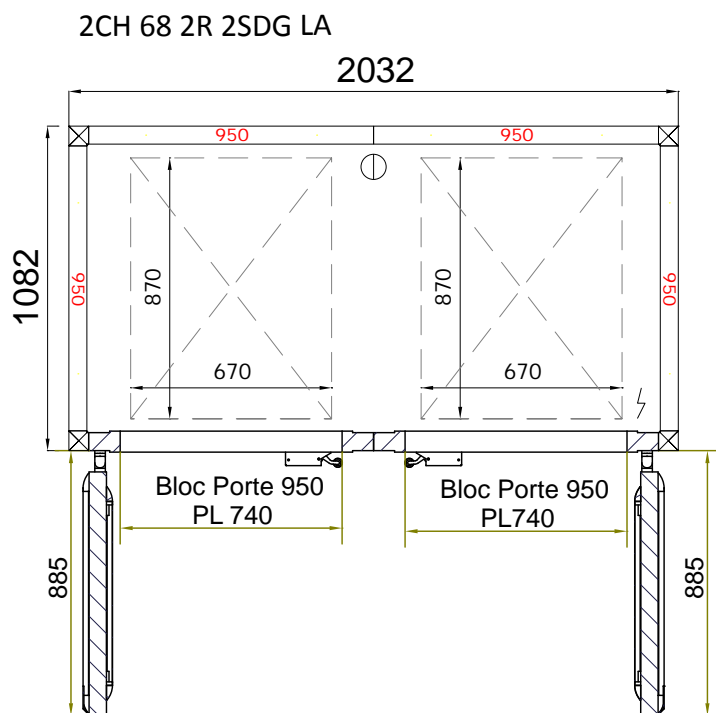

# Boreal Paneotrad 600x800 - 3 racks

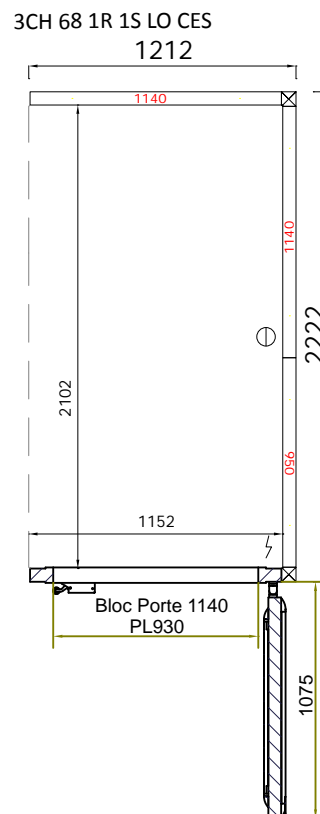
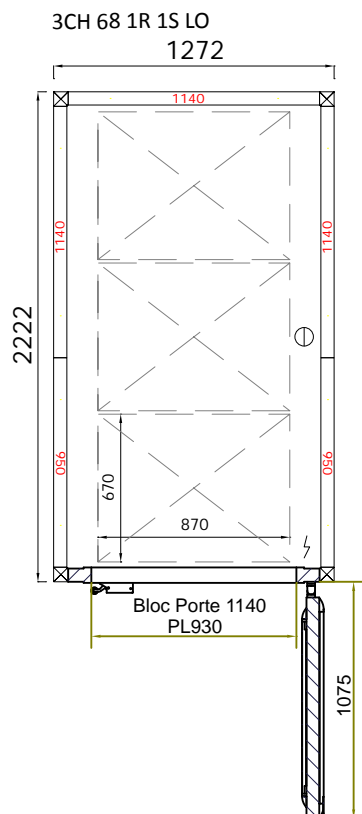
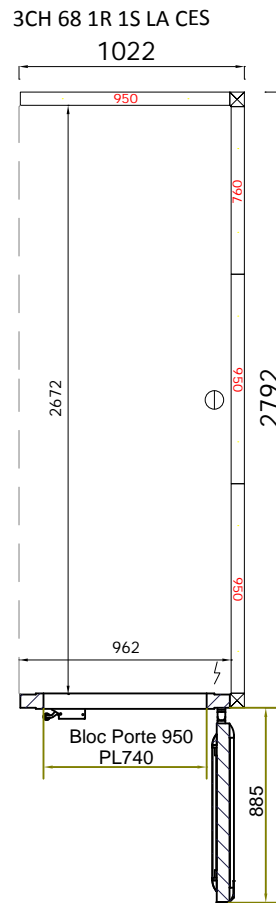
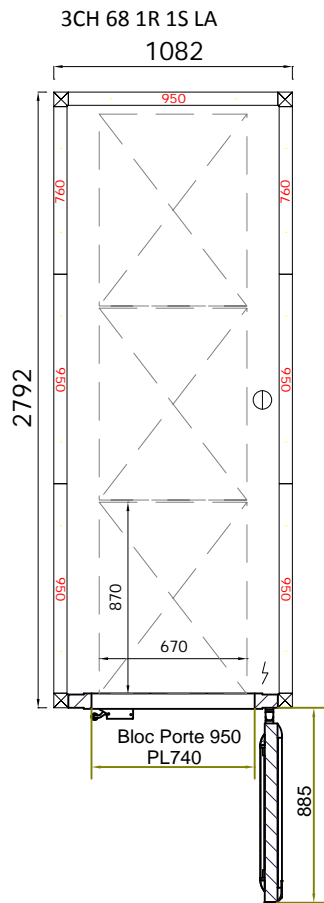



# Boreal Paneotrad 600x800 - 3 racks

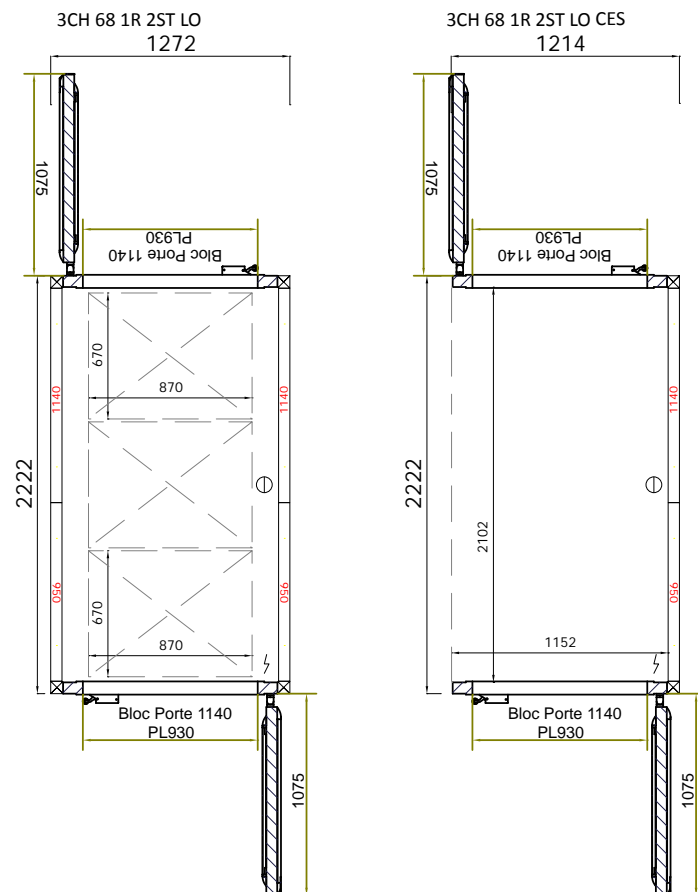
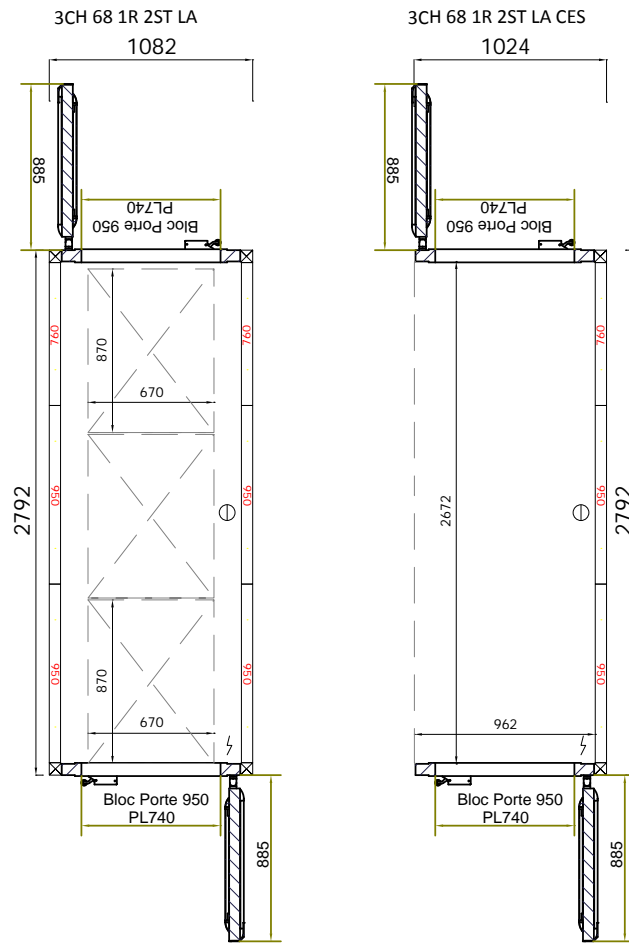

# Boreal Paneotrad 600x800 - 3 racks

3CH 68 3R 1SD LA

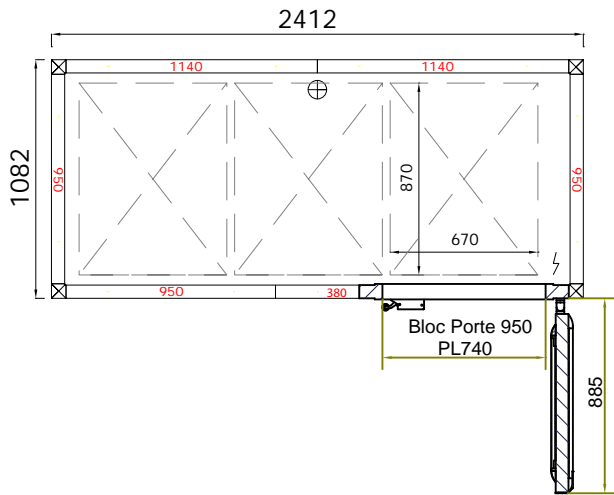

3CH 68 3R 1SD LA CES

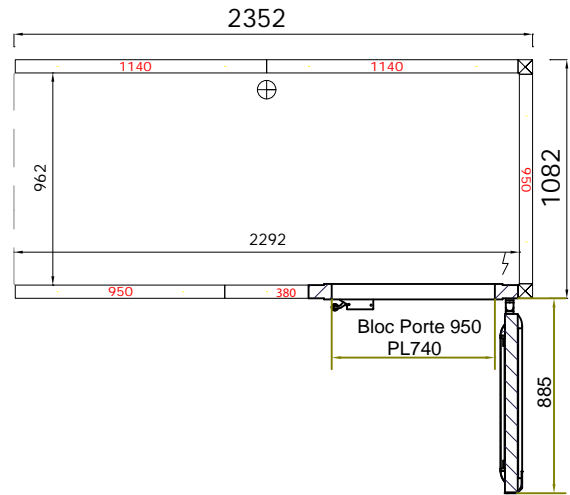

3CH 68 3R 1DBD LA

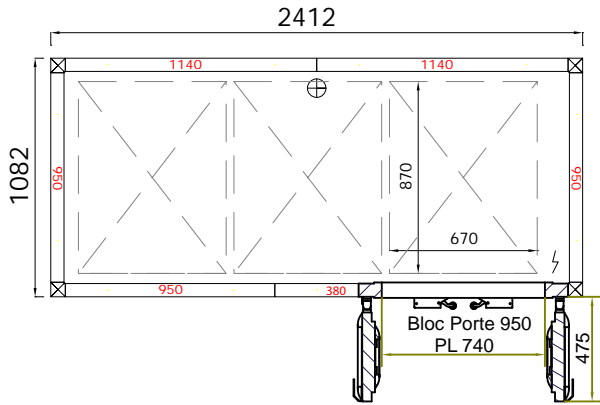

3CH 68 3R 1DBD LA CES

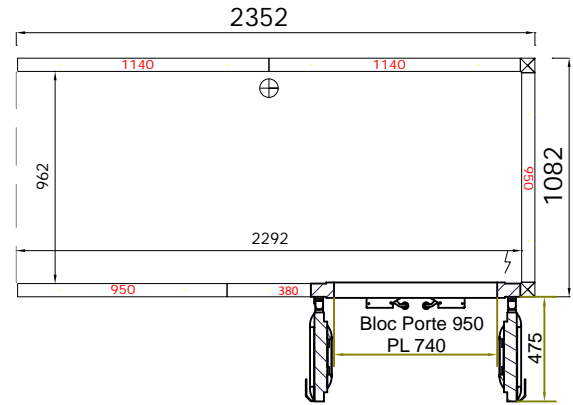

3CH 68 3R 1SD LO

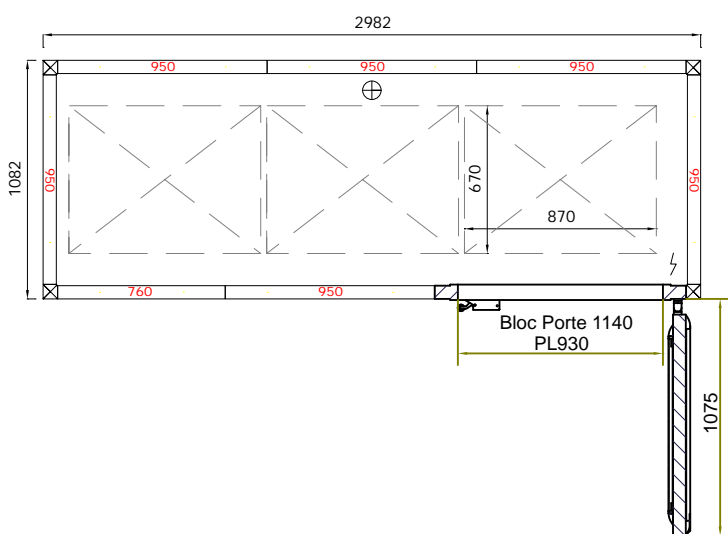

3CH 68 3R 1SD LO CES

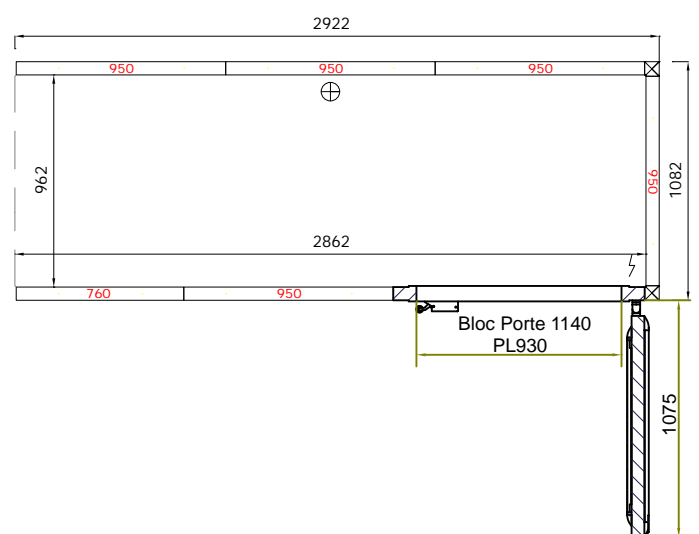

# Boreal Paneotrad 600x800 - 3 racks

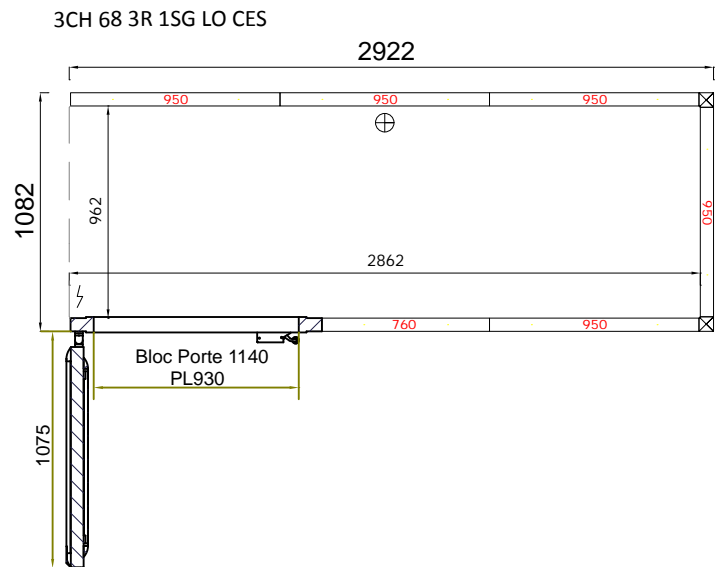
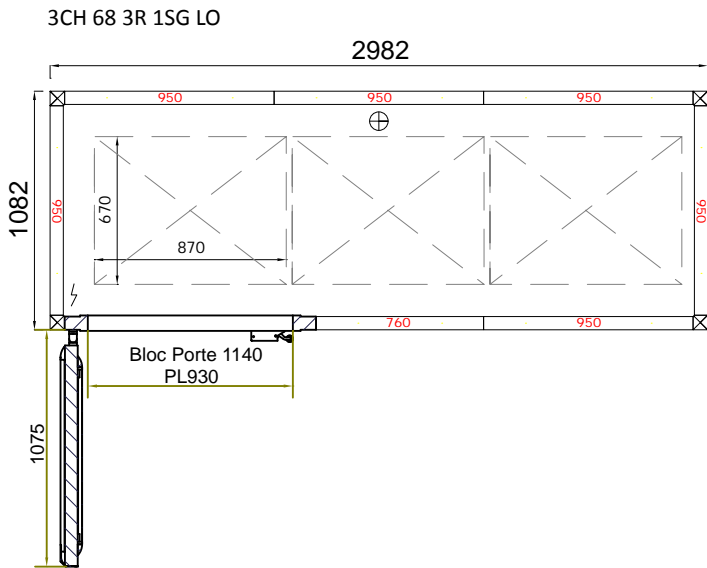
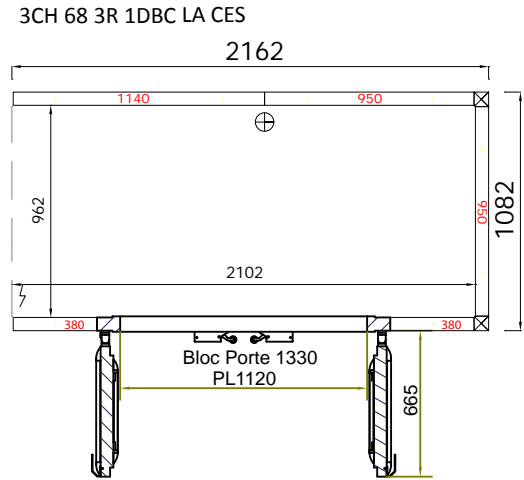
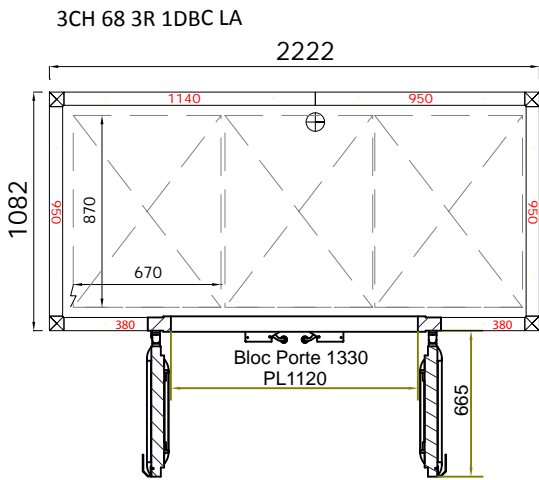
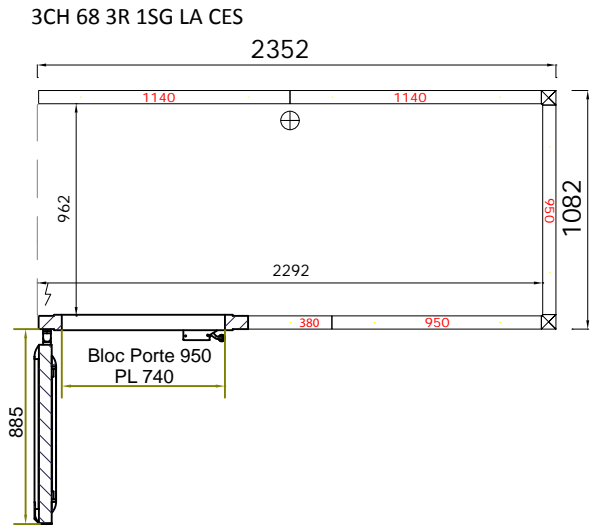
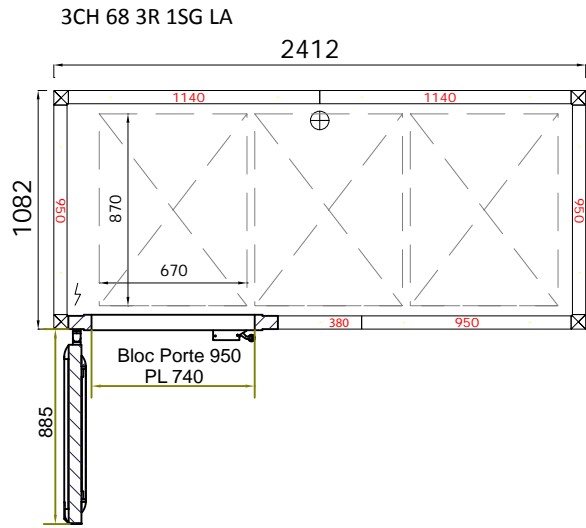

# Boreal Paneotrad 600x800 - 3 racks

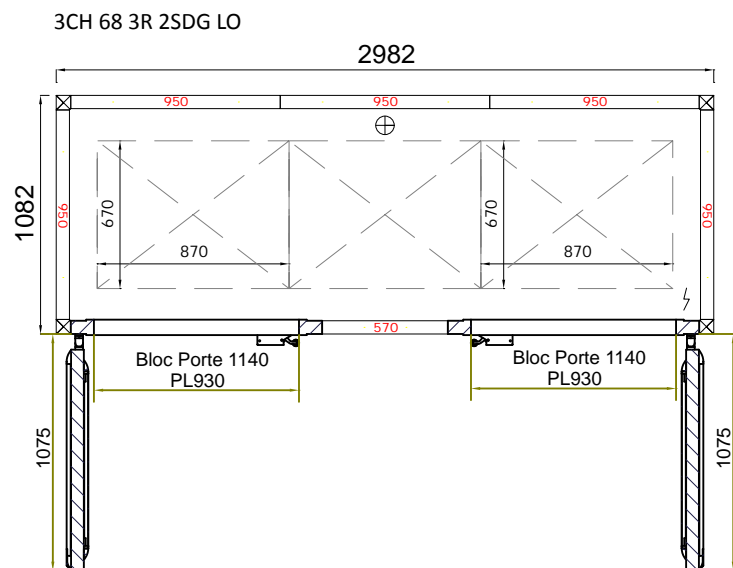
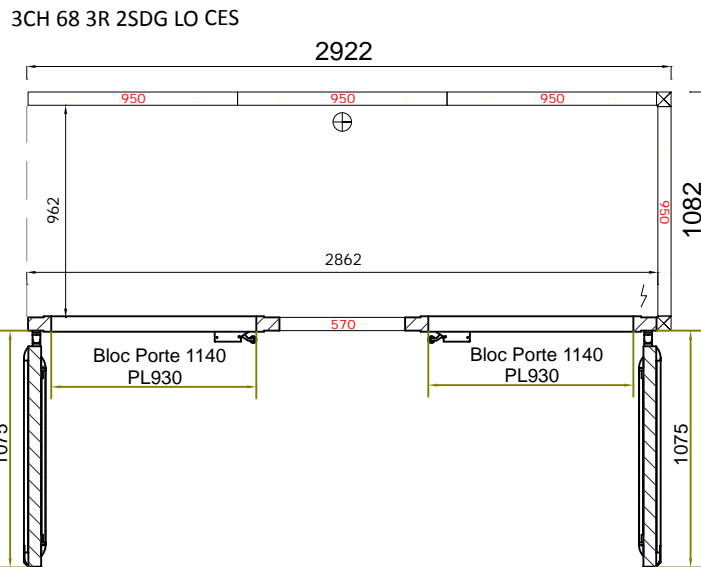
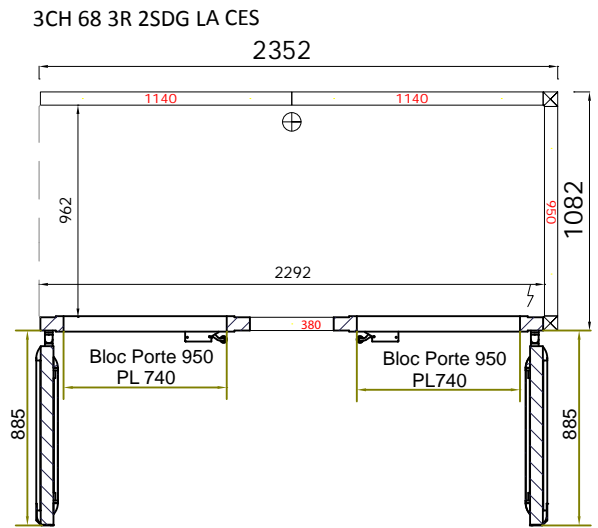
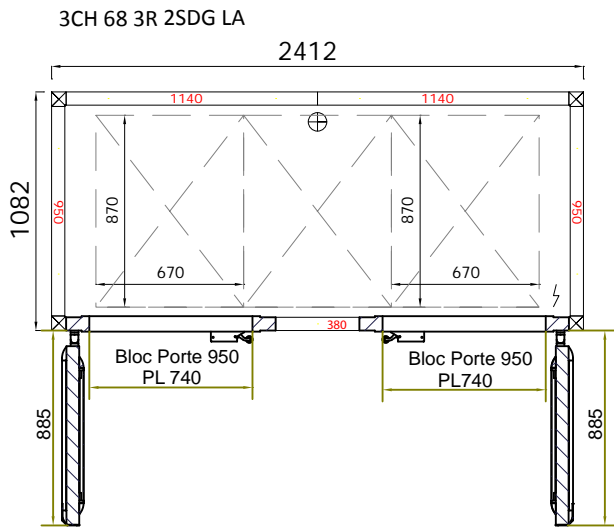

# Boreal Paneotrad 600x800 - 4 racks

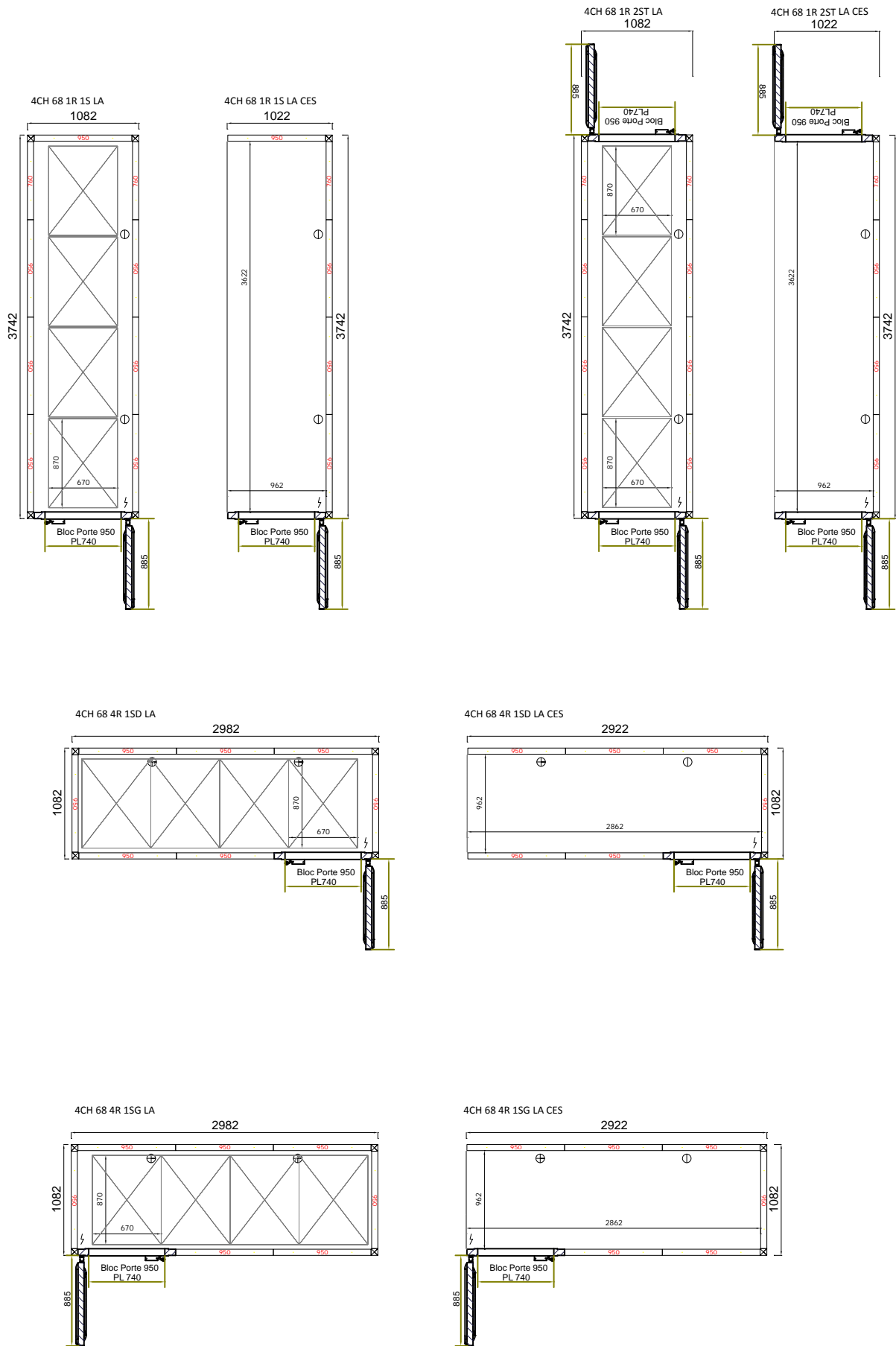

# Boreal Paneotrad 600x800 - 4 racks

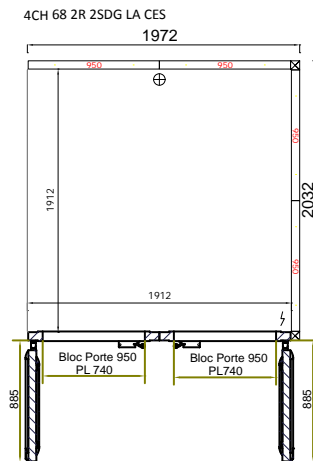
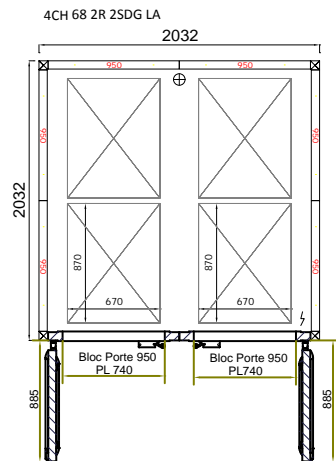
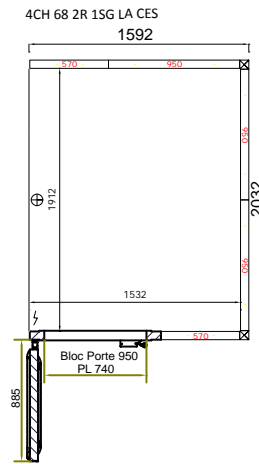
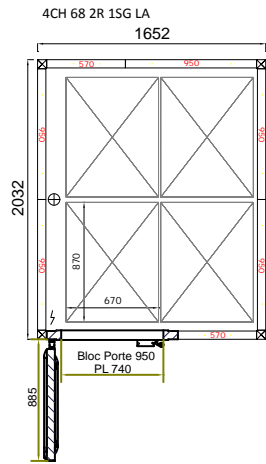
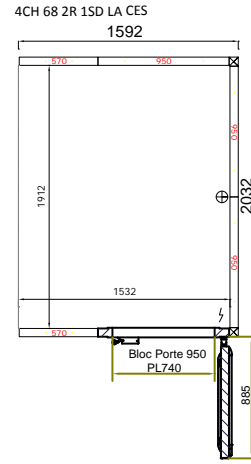
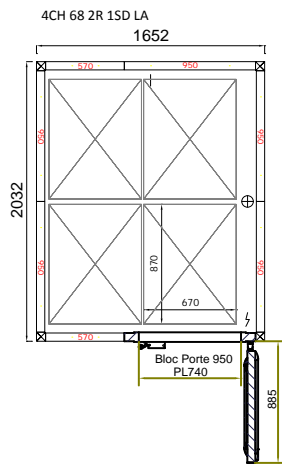
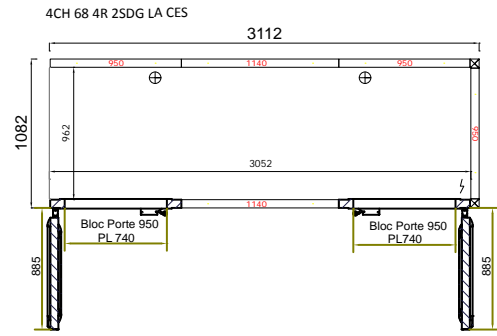
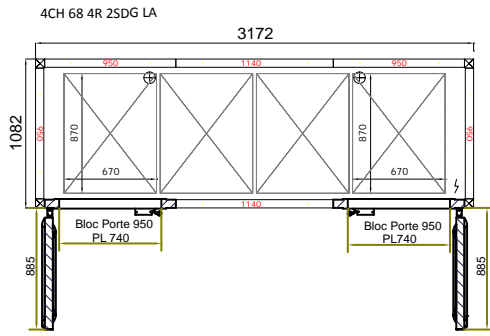

# Boreal Paneotrad 600x800 - 4 racks

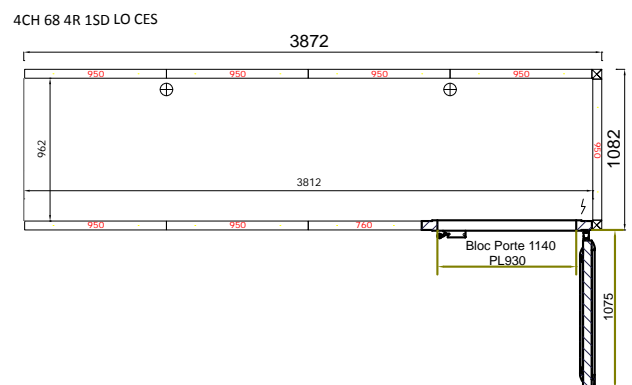
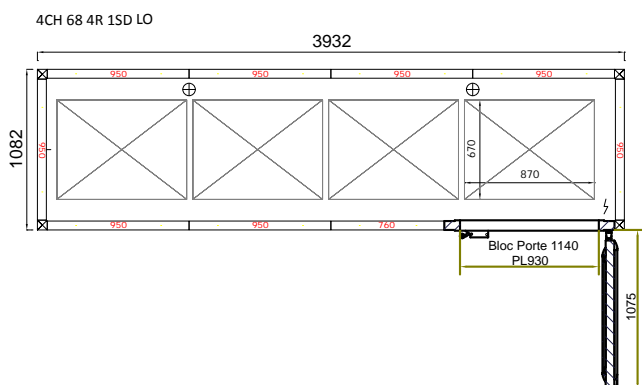
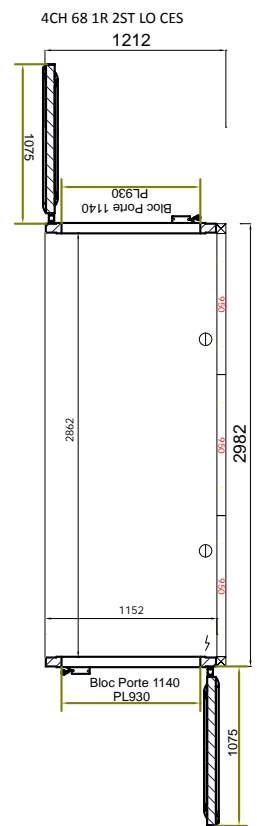
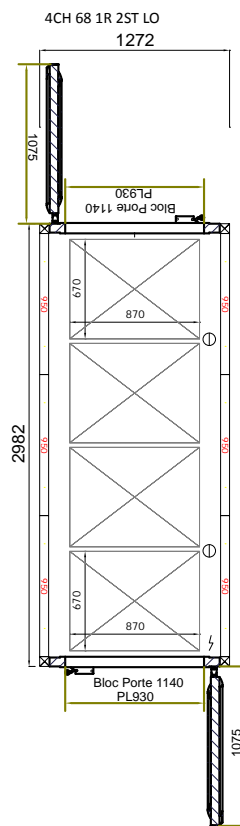
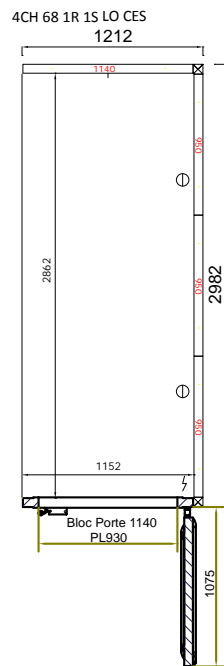
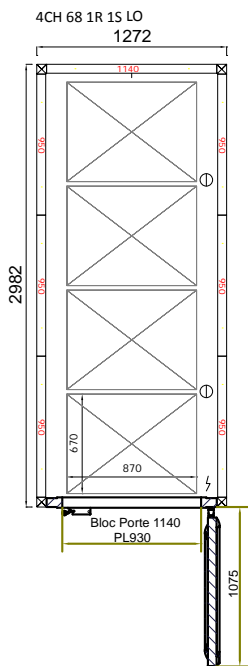
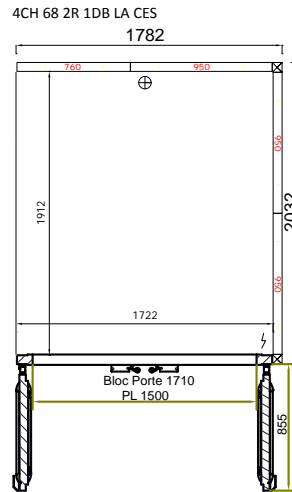
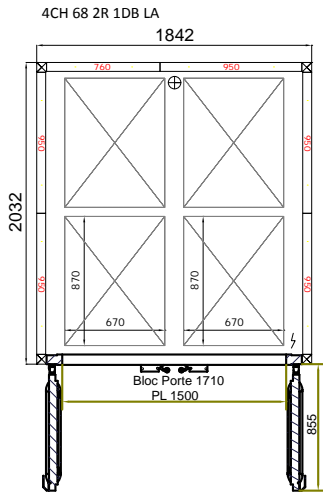

# Boreal Paneotrad 600x800 - 4 racks

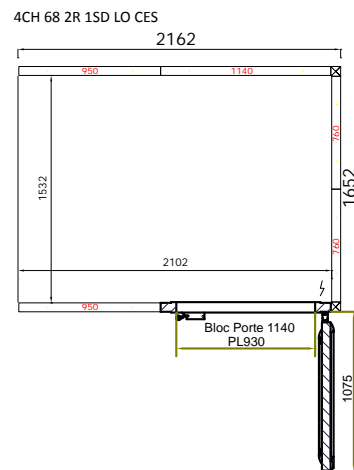
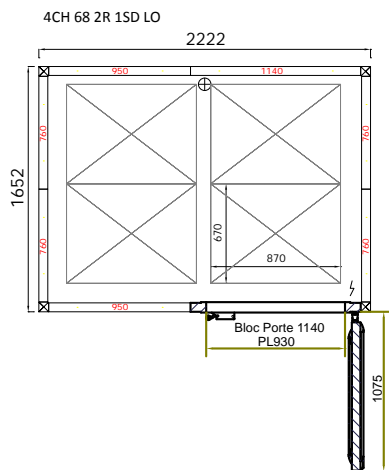
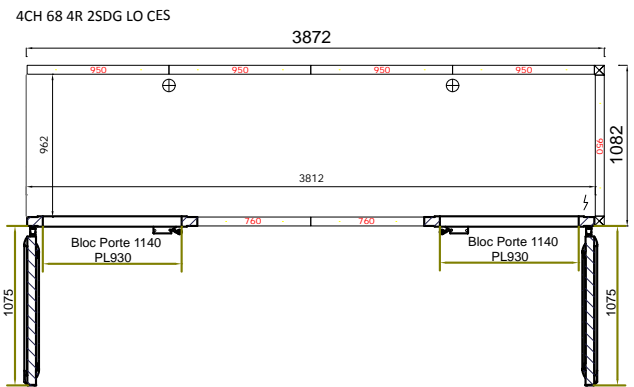
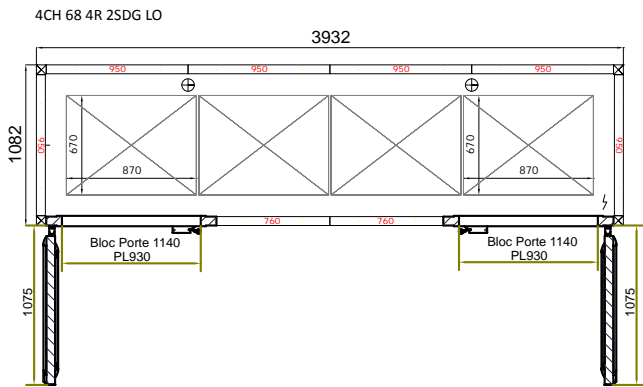
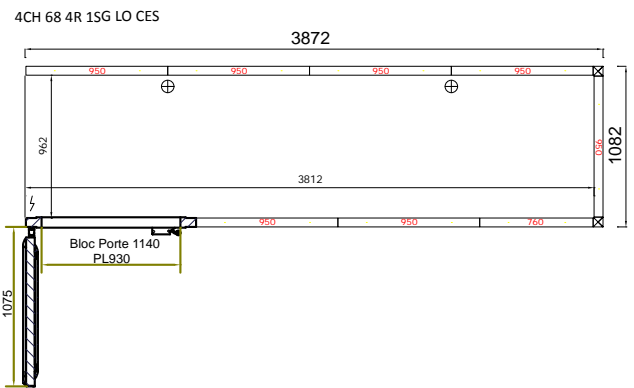
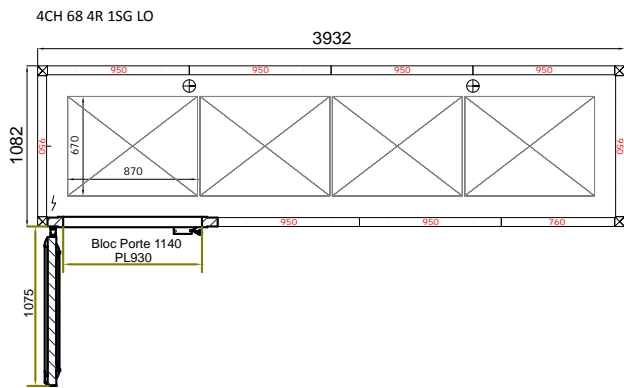



# Boreal Paneotrad 600x800 - 4 racks

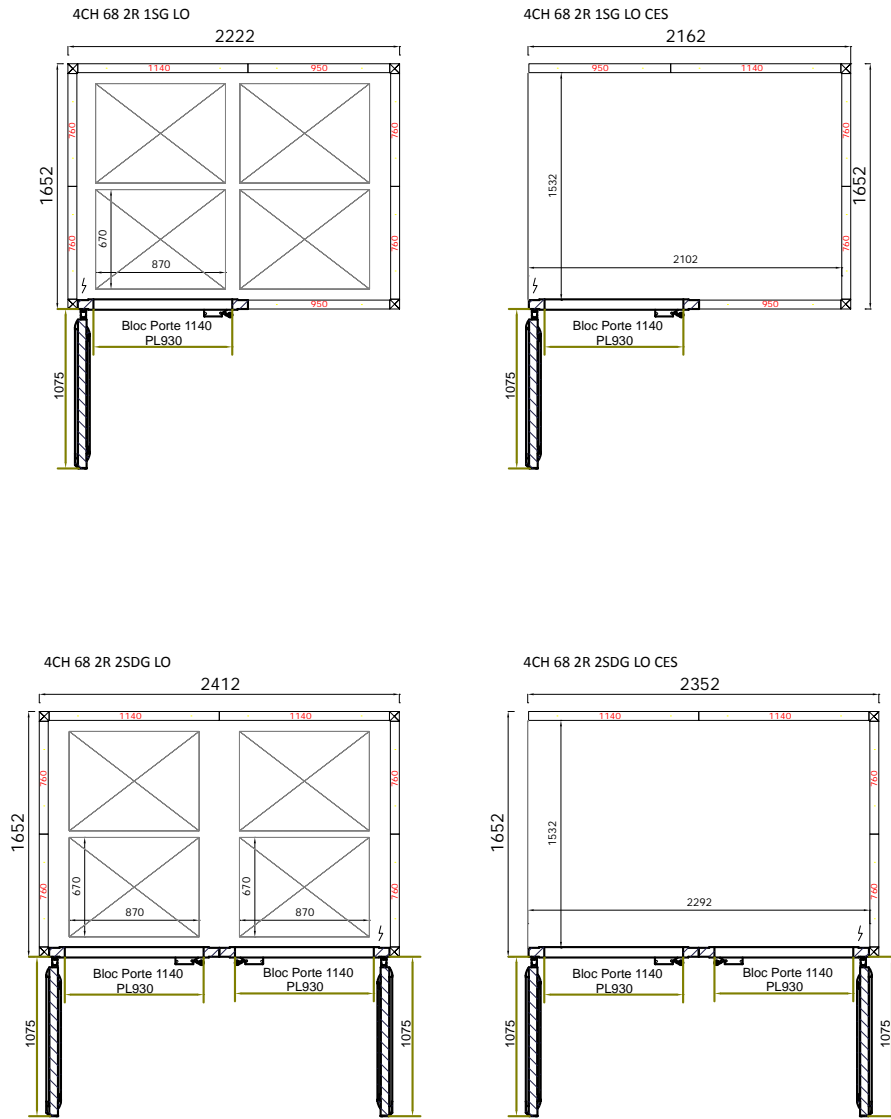

# Boreal Paneotrad 600x800 - 6 racks

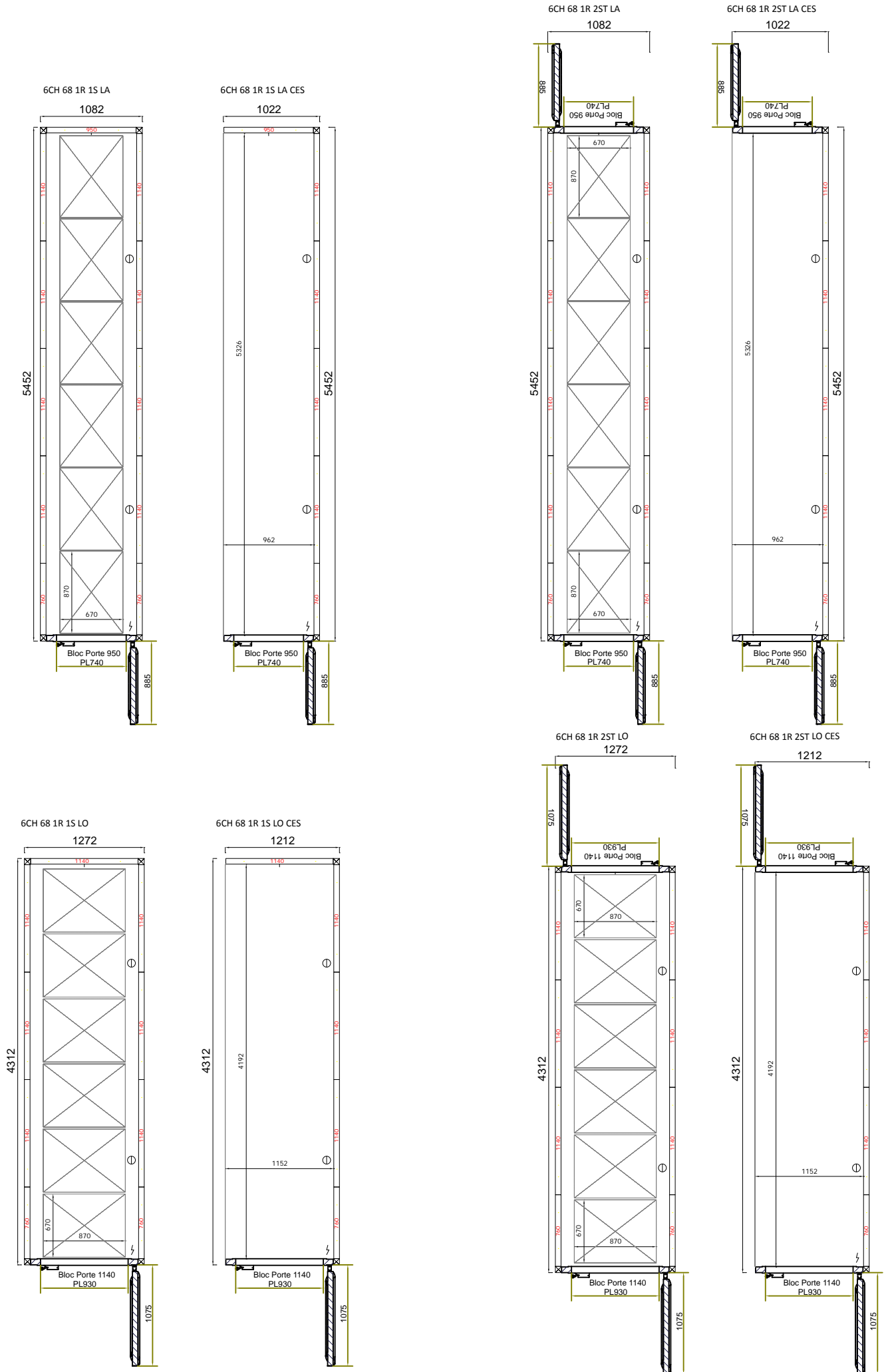

# Boreal Paneotrad 600x800 - 6 racks

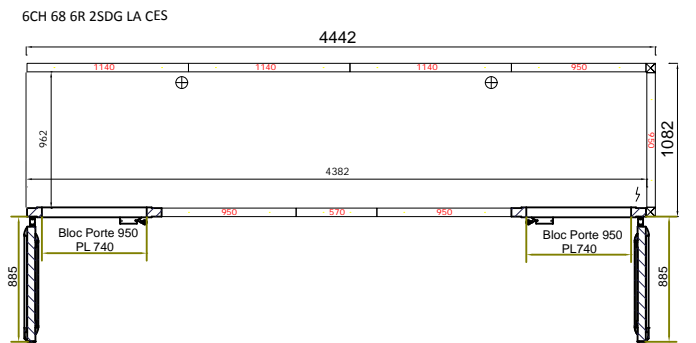
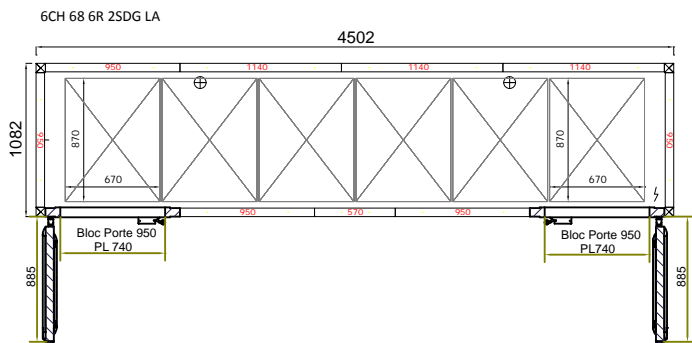
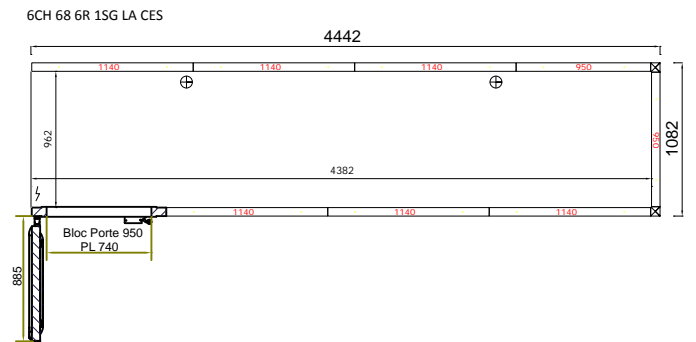
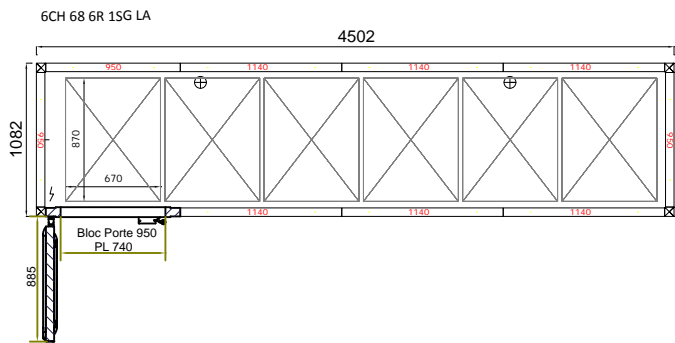
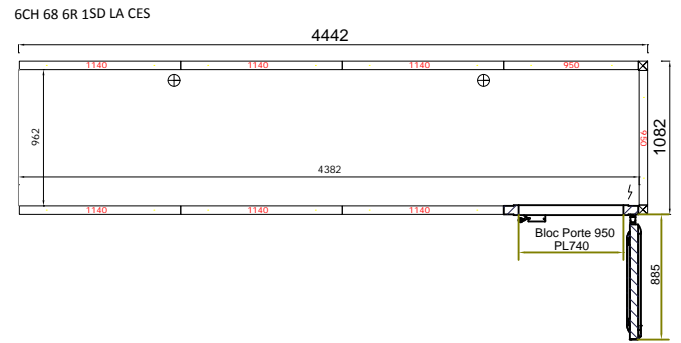
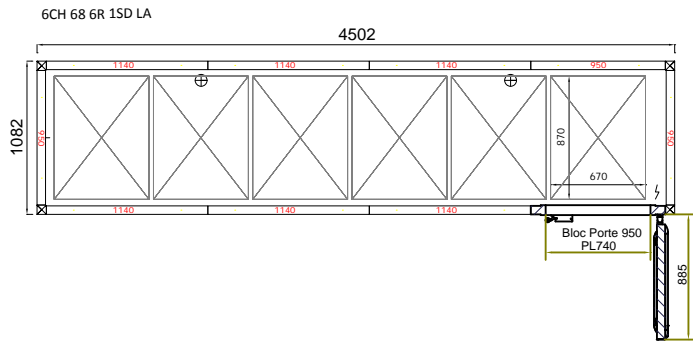

# Boreal Paneotrad 600x800 - 6 racks

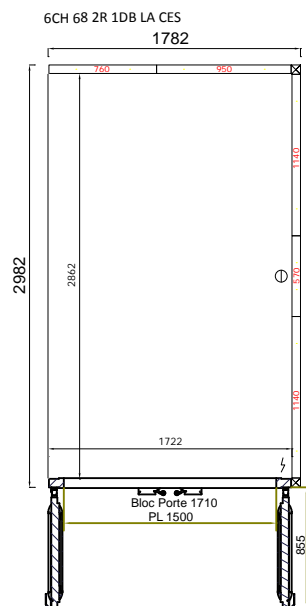
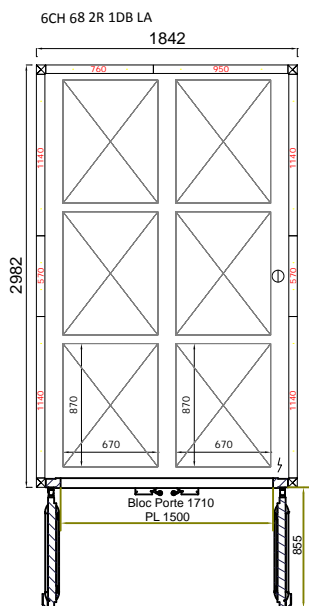
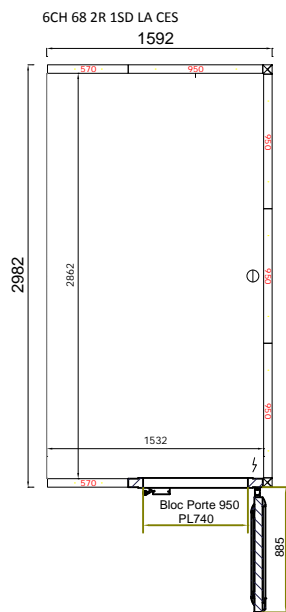
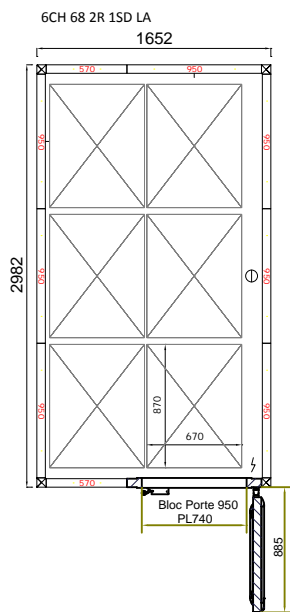
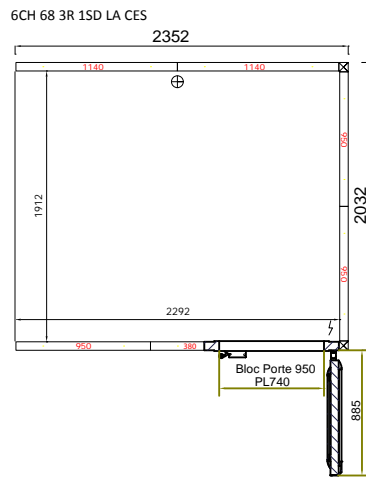
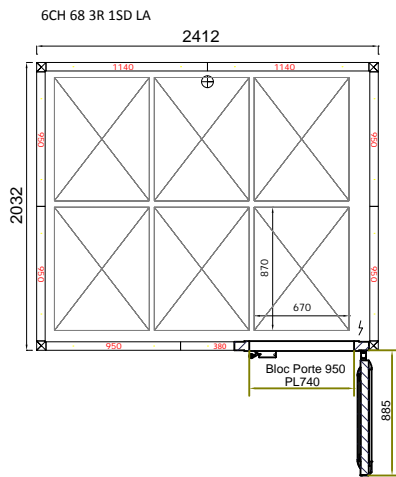

# Boreal Paneotrad 600x800 - 6 racks

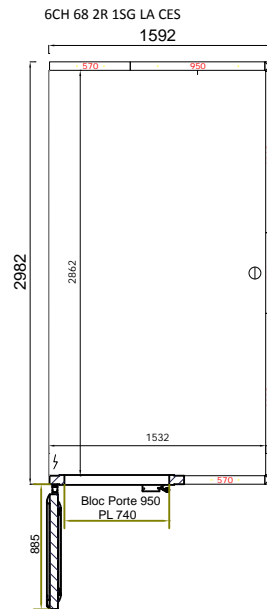
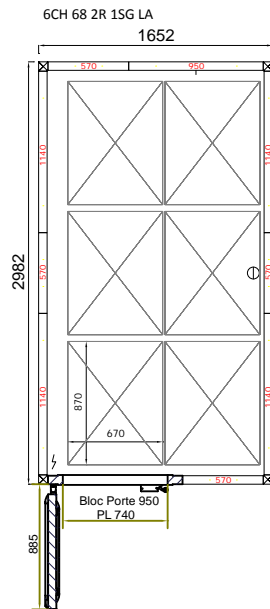
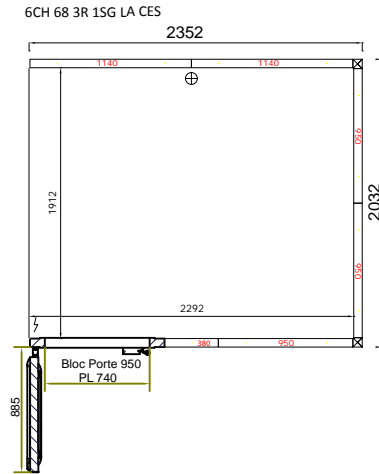
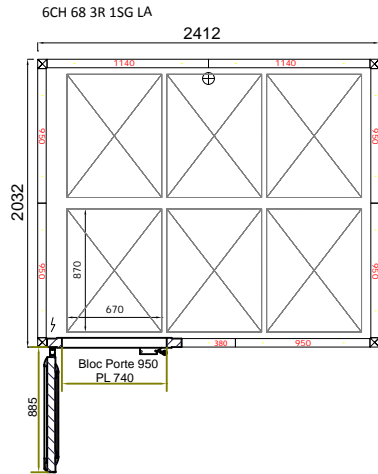

# Boreal Paneotrad 600x800 - 6 racks

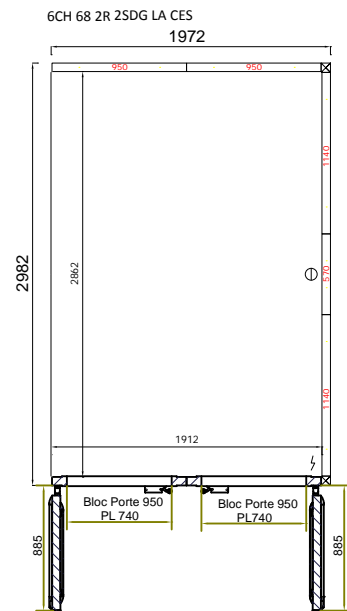
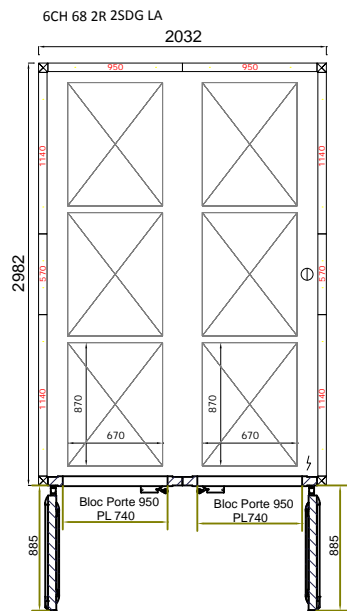
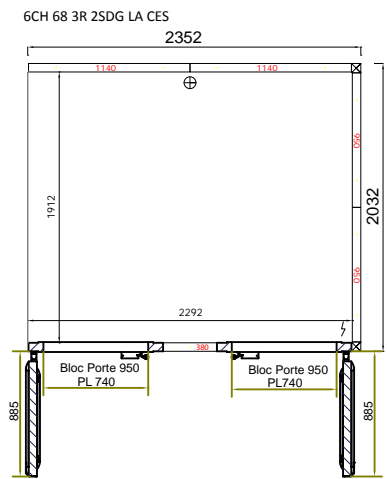
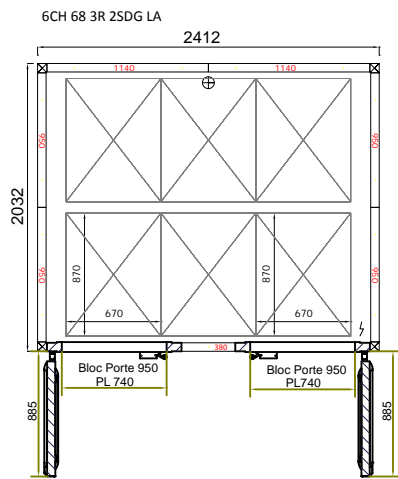

# Boreal Paneotrad 600x800 - 6 racks

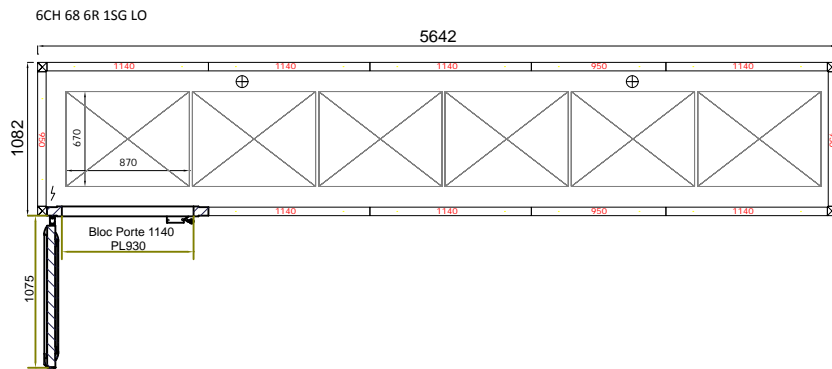
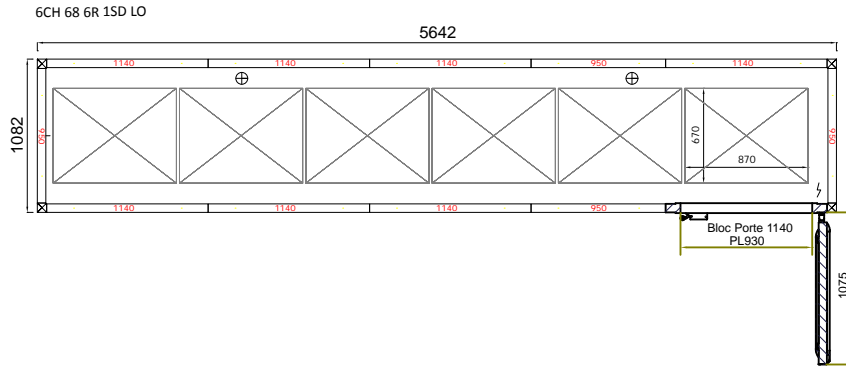

# Boreal Paneotrad 600x800 - 6 racks

6CH 68 6R 2SDG LO CES

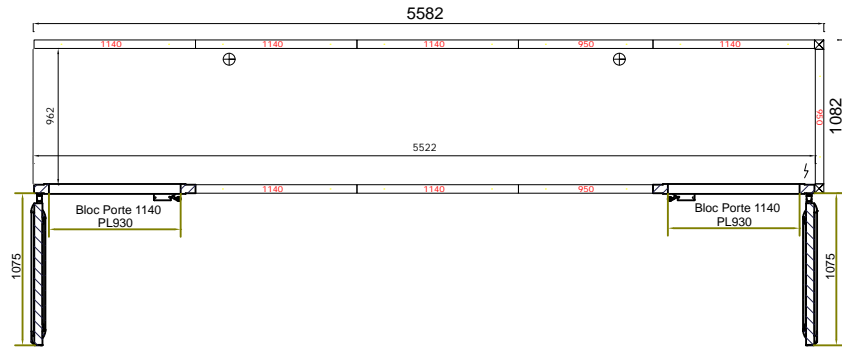

6CH 68 3R 1SG LO

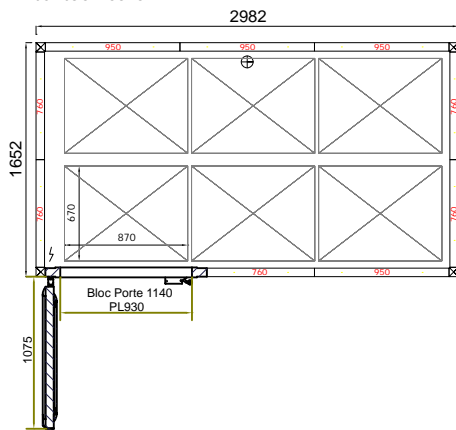

6CH 68 3R 1SG LO CES

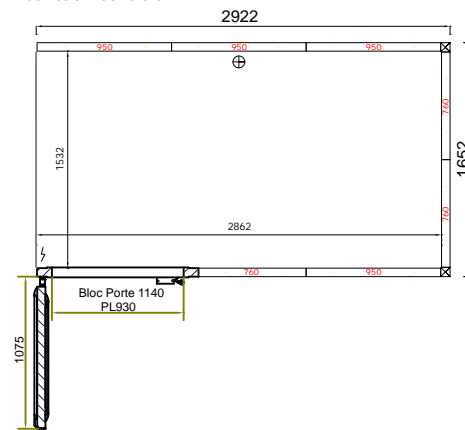

6CH 68 2R 1SG LO

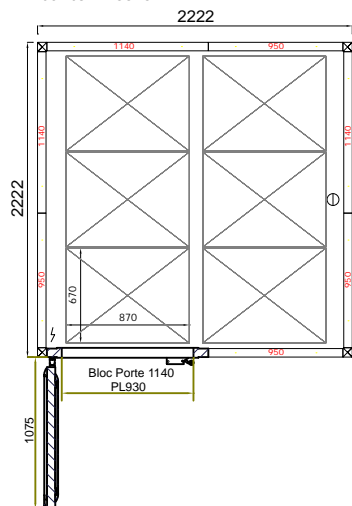

6CH 68 2R 1SG LO CES

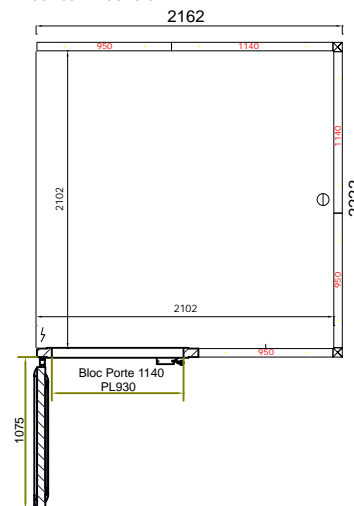



# Boreal Paneotrad 600x800 - 6 racks

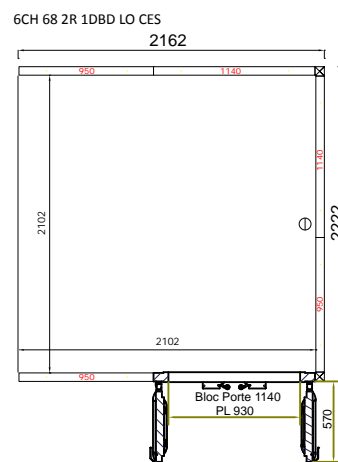
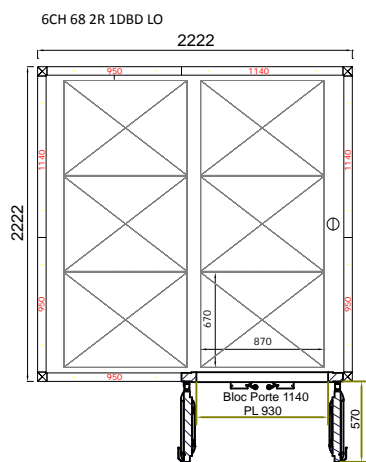
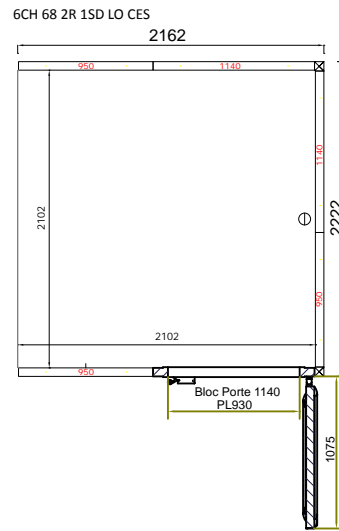
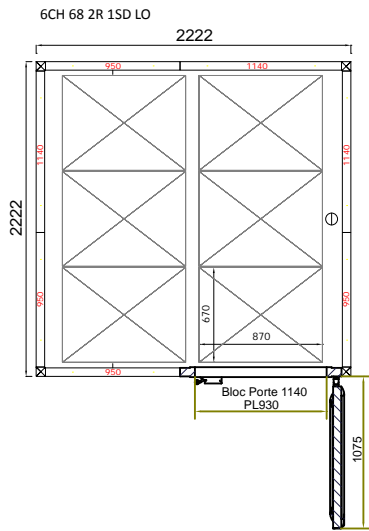
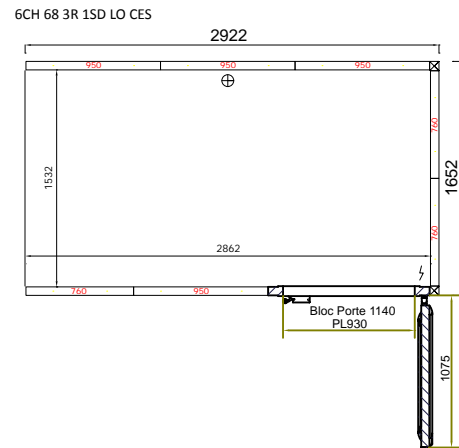
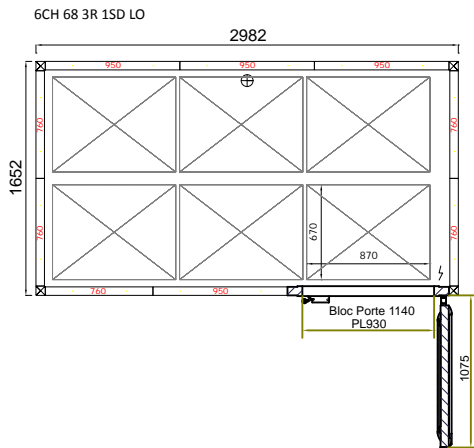

# Boreal Paneotrad 600x800 - 6 racks

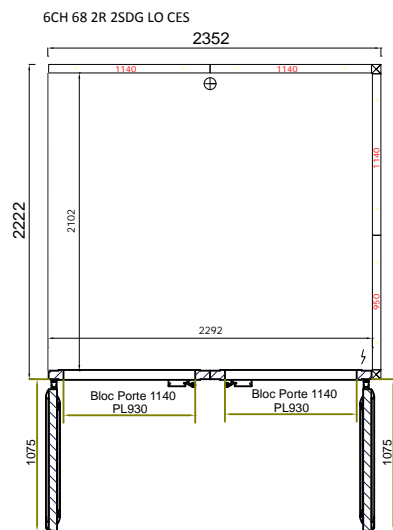
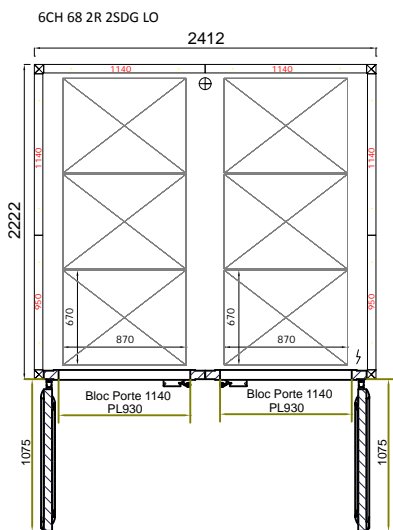
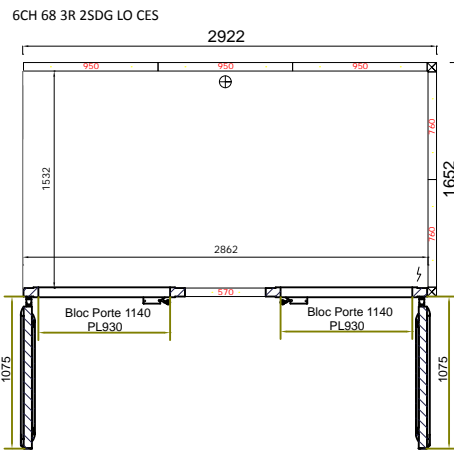
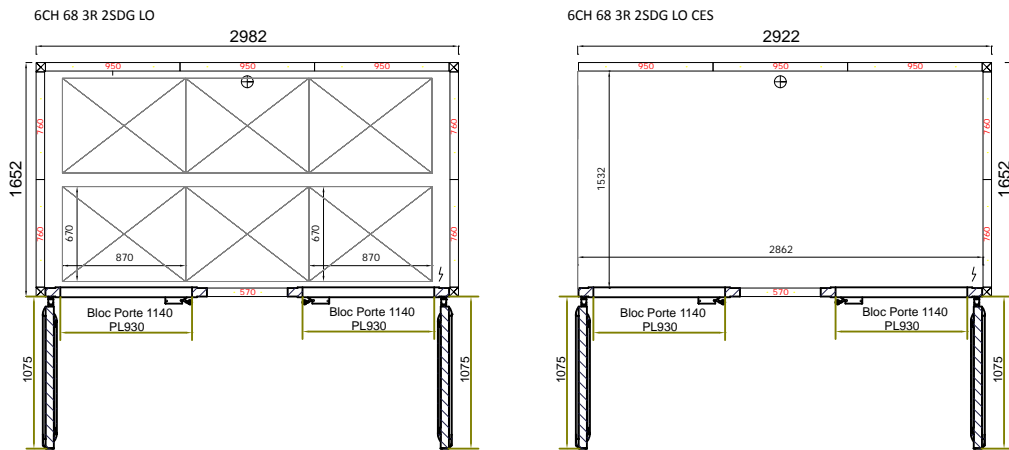

# Boreal Paneotrad 600x800 - 8 racks

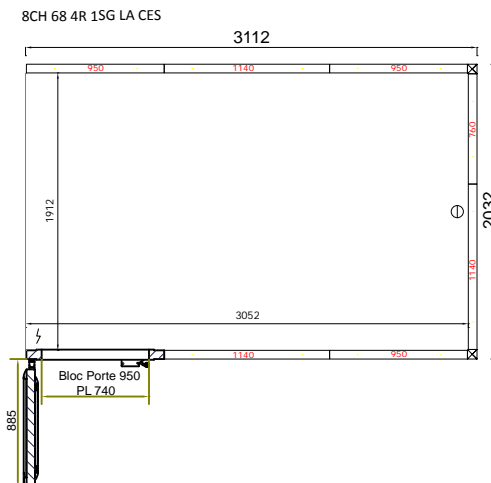
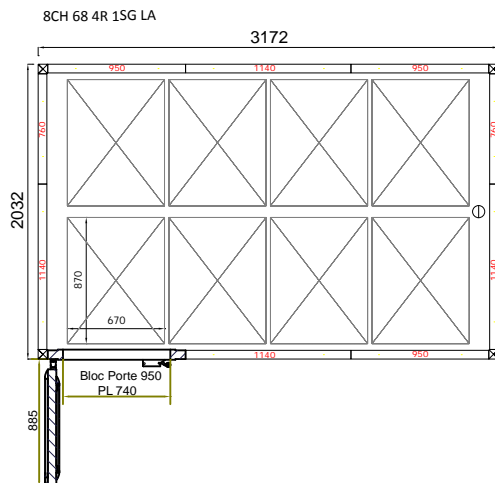
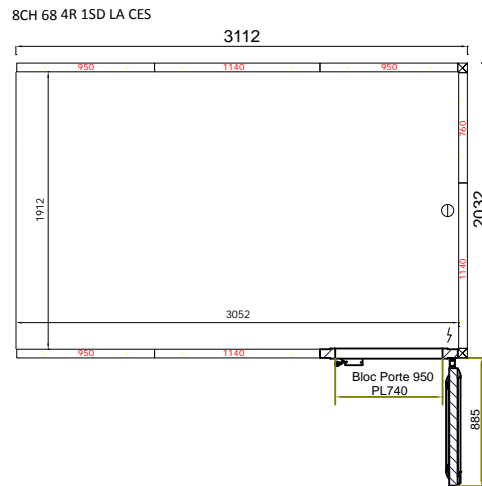
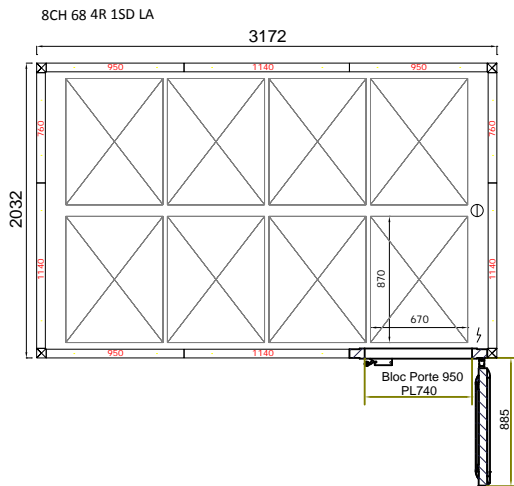
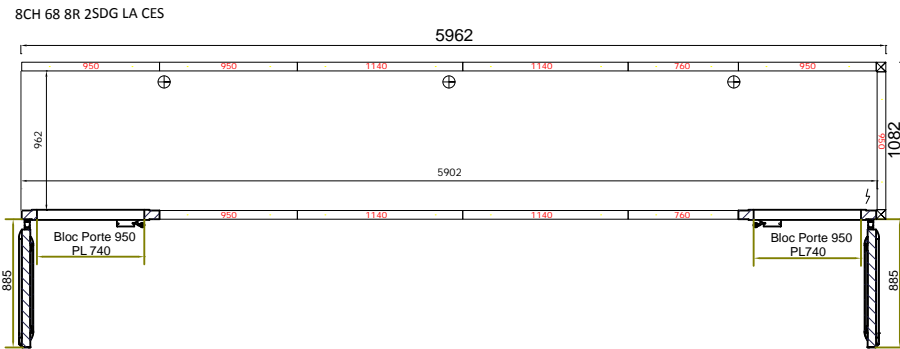
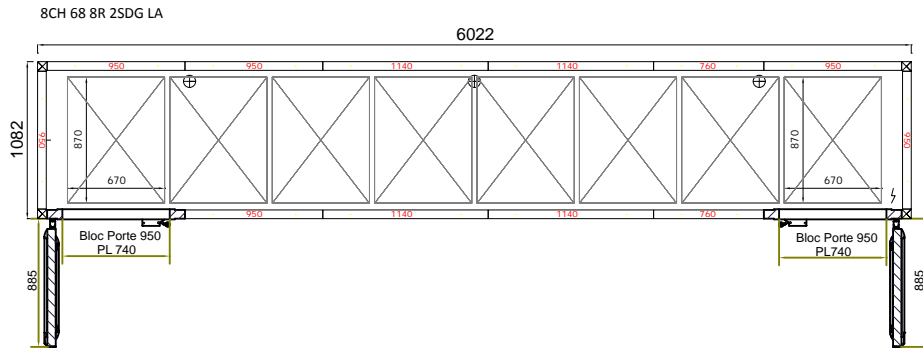

# Boreal Paneotrad 600x800 - 8 racks

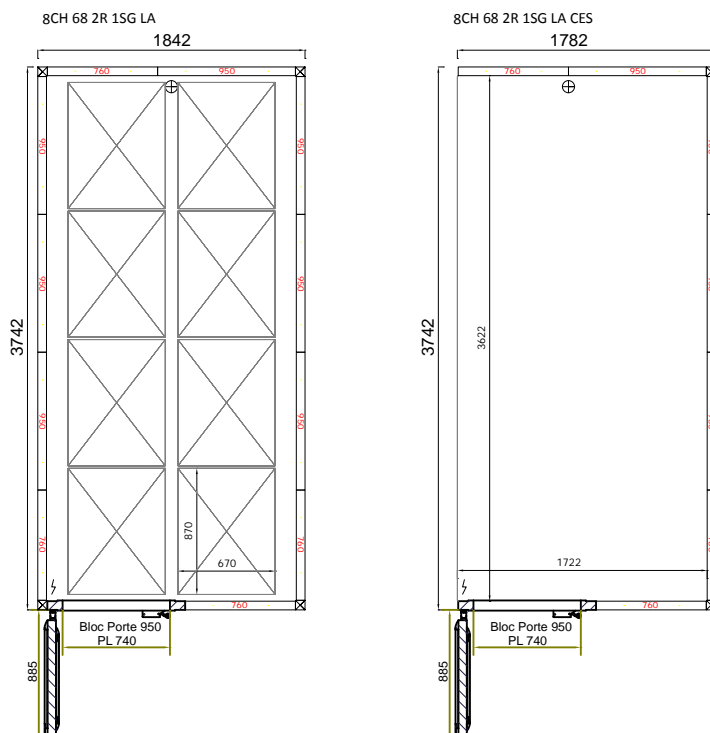
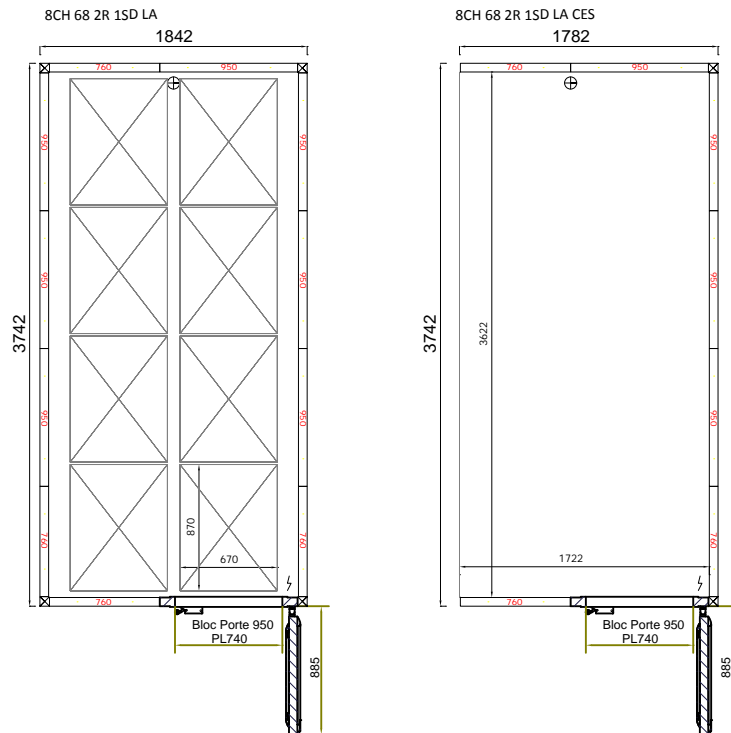
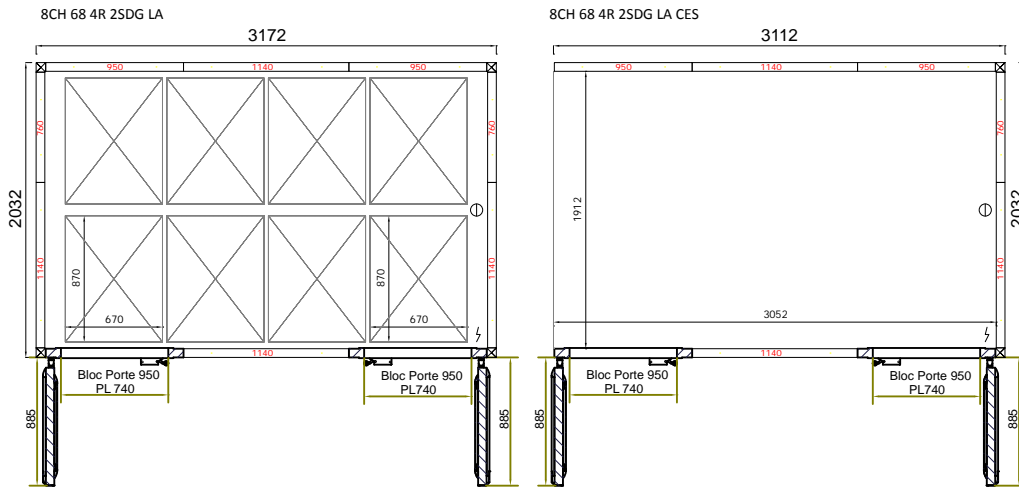

# Boreal Paneotrad 600x800 - 8 racks

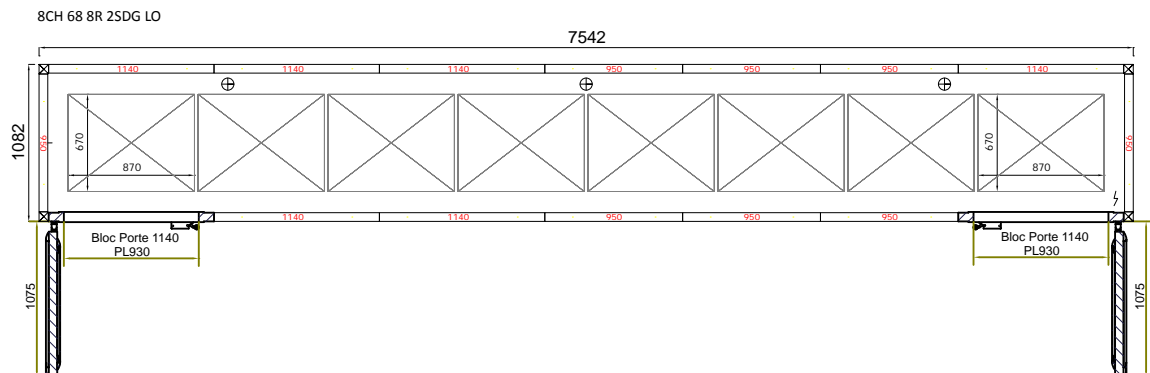
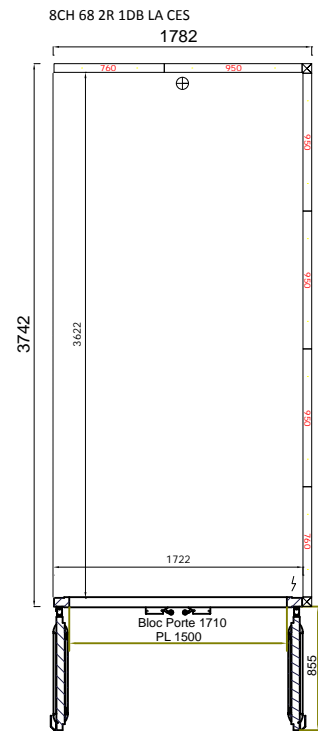
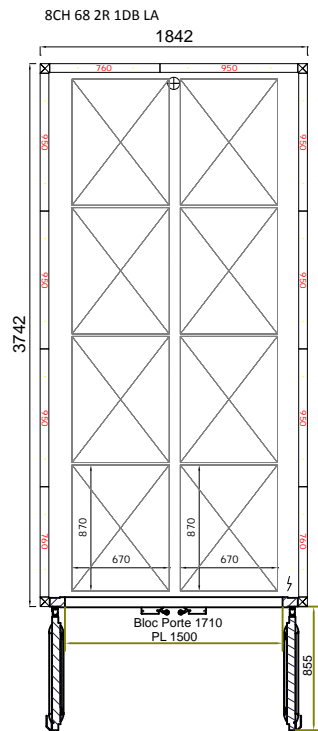
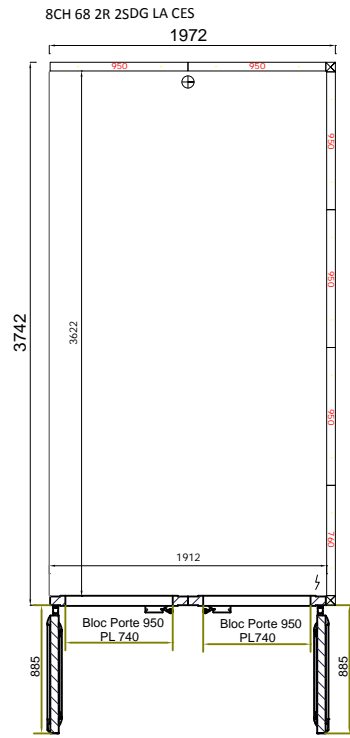
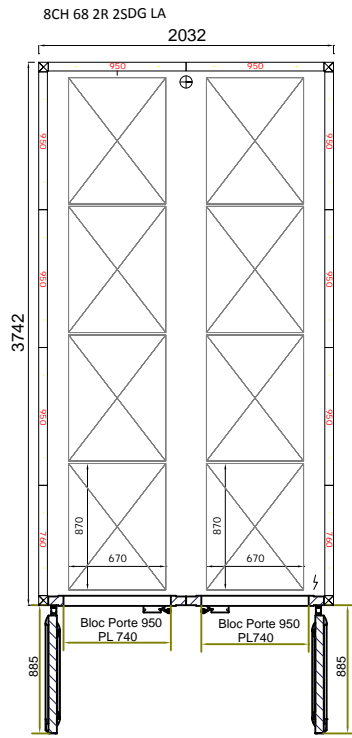

# Boreal Paneotrad 600x800 - 8 racks

8CH 68 8R 2SDG LO CES

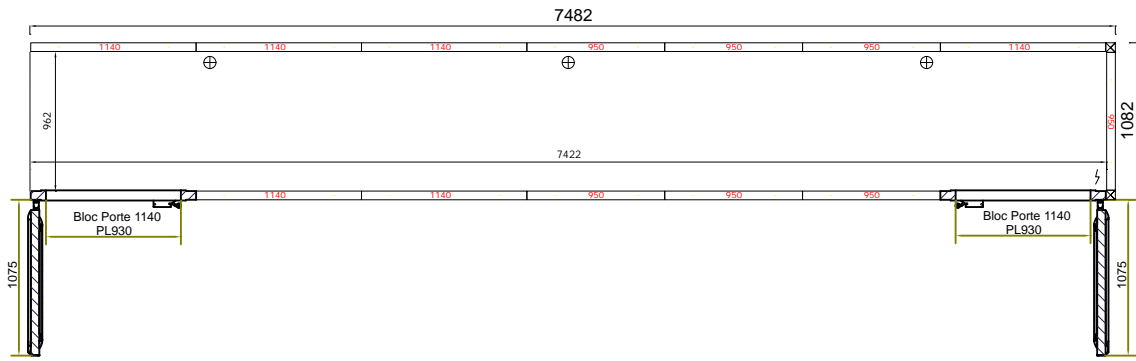

8CH 68 4R 1SD LO

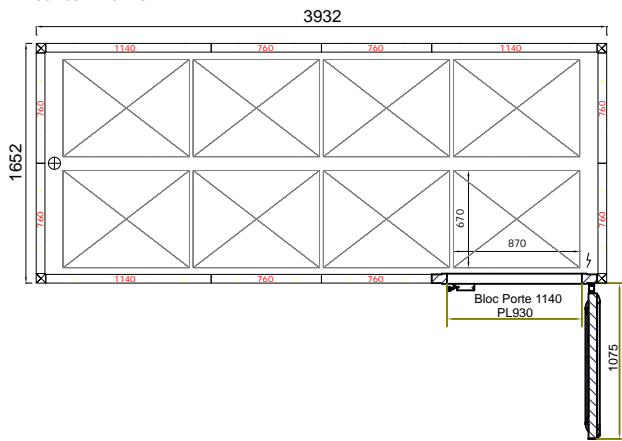

8CH 68 4R 1SD LO CES

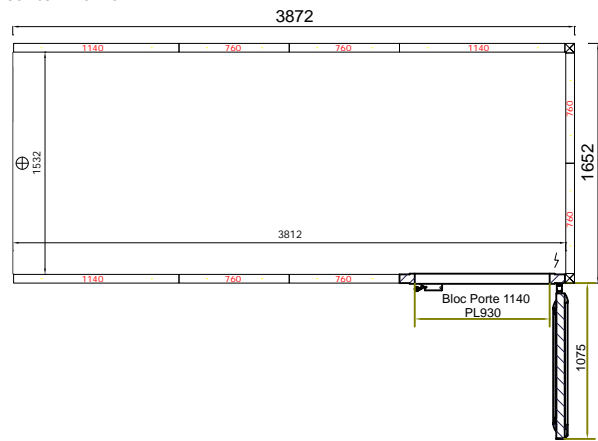

8CH 68 4R 1SG LO

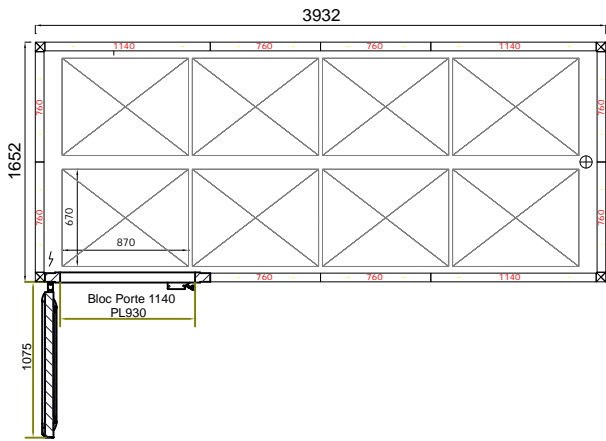

8CH 68 4R 1SG LO CES

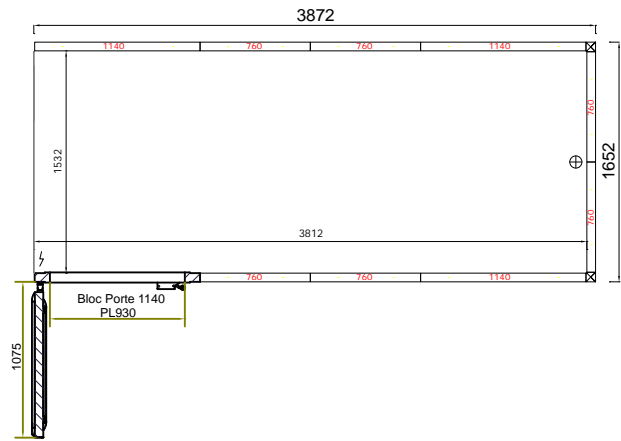

8CH 68 4R 2SDG LO

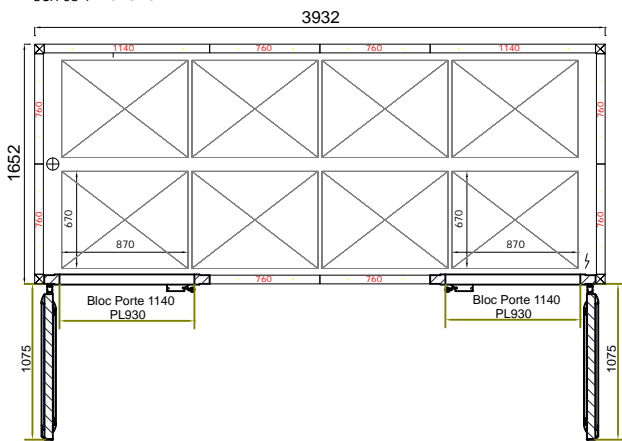

8CH 68 4R 2SDG LO CES

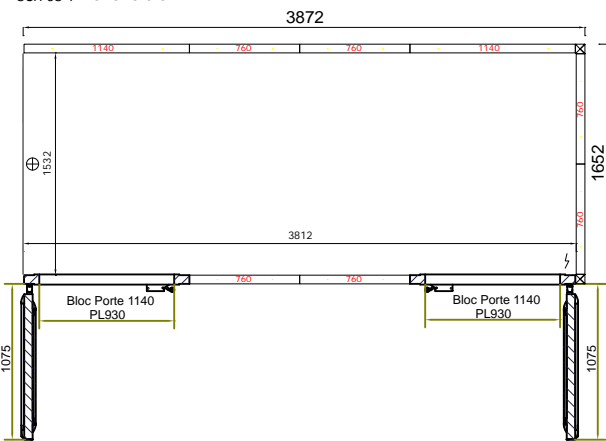

# Boreal Paneotrad 600x800 - 8 racks

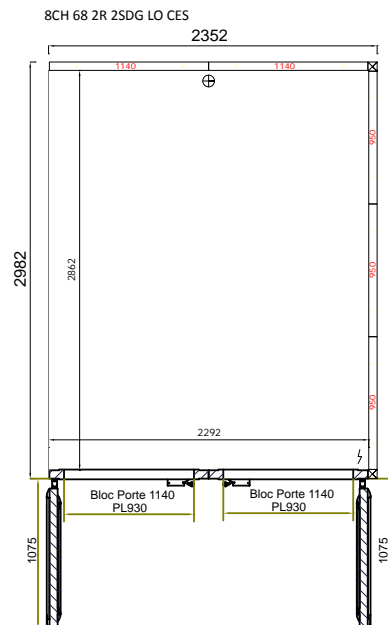
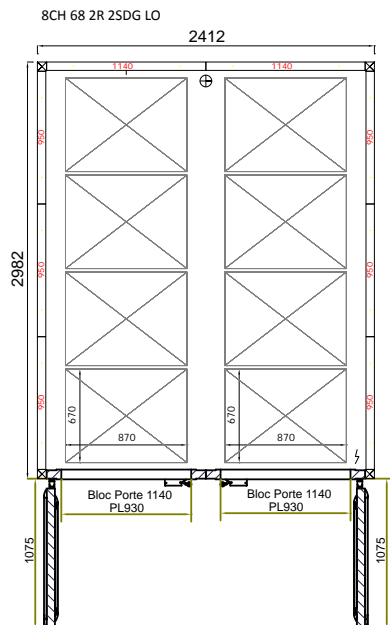
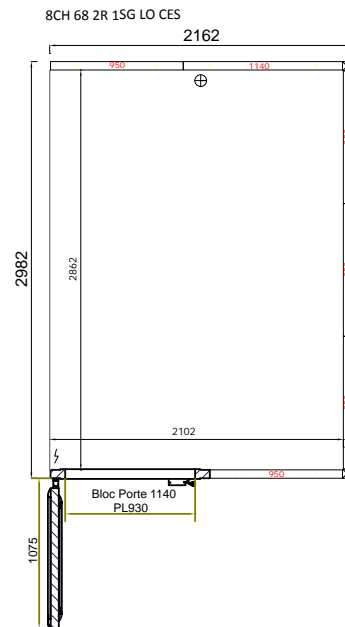
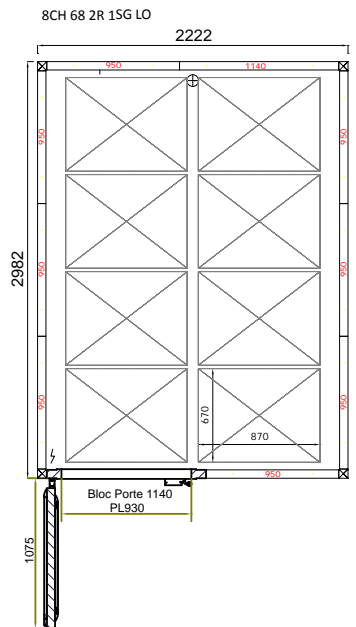
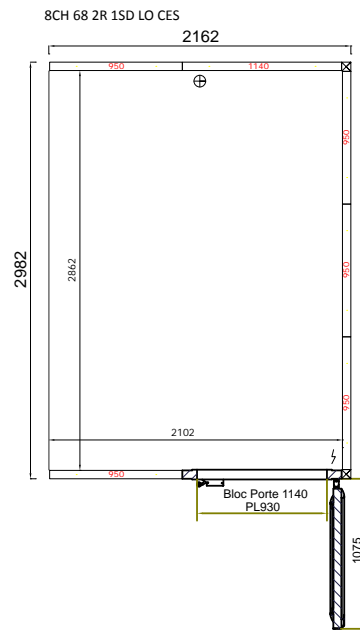
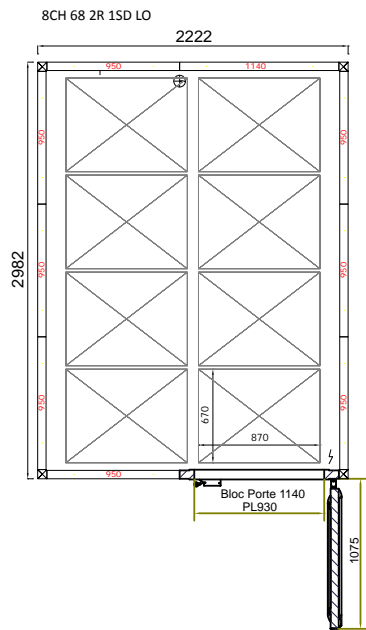



## Refrigerated "pastry" type workbench

### Performances

- Available in 2 , 3 and 4 doors
- Capacity : 8 levels per door with a spacing of 55 mm, bringing the storage capacity from 16 to 32 trays 400 x 600 mm according to the chosen model

### The advantages

- Regulation by electronic thermostat
- Drain not necessary
- Easy to remove tray slide
- Easy to clean
- Automatic closure of the doors with spring pivot

### Use

The **BTP** refrigerated workbench is designed to store pastry products.

### Operating principle

Fresh products are conserved in an isotherm unit at a temperature between 0°C and 10°C on 400x600 mm trays. Ventilated cold maintains an even temperature throughout the cell.

### Construction

- Isothermal panels (55 mm thick) inside and outside, internal and external of stainless steel AISI 304
- Granite top (30 mm thick) or S/S top in AISI 304
- Adjustable legs
- Workbench with recycling of condensation water
- Very easily removable "U-rails" with tray slides made of S/S (spacing of 55 mm)
- Built-in compressor
- Freon gas type R 134A
- Regulation of temperature by electronic thermostat (0°C to +10°C)
- Electric supply : 220-250 V - Single PH - 50 HZ



# Bongard refrigerated workbench **BTP**

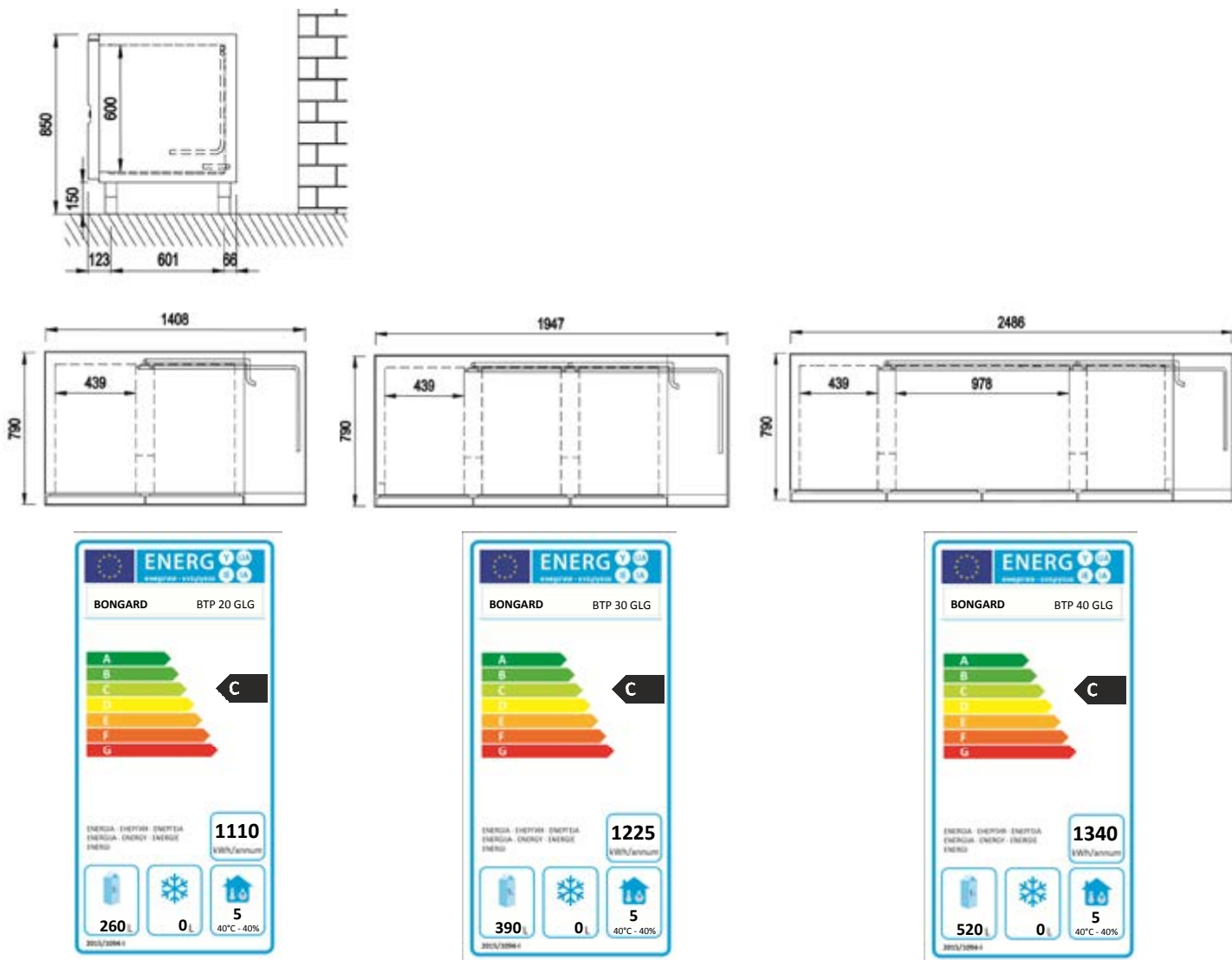

Model		BTP20 GLG	BTP30 GLG	BTP40 GLG
Energetic class		C	C	C
Energy efficiency index		45,21	44	42,9
Consumption for 24h	(kW)	3,04	3,36	3,67
Annual consumption	(kW)	1110	1225	1340
Usefull volume in each compartment	(litre)	260	390	520
Ambiance class		5	5	5
working temperature		M1	M1	M1
Refrigerating fluid		R134a (1430)		

Built-in compressor - with granite worktop					
Type	Number of doors	Dimensions (mm) W x D x H	Depth with door open (mm)	Number of trays 400 x 600	Connecting Power (kW)
BTP 20GLG	2	1408 x 790 x 880	1270	16	0,28
BTP 30GLG	3	1947 x 790 x 880	1270	24	0,34
BTP 40GLG	4	2486 x 790 x 880	1270	32	0,39

Built-in compressor - with Stainless Steel worktop					
Type	Number of doors	Dimensions (mm) W x D x H	Depth with door open (mm)	Number of trays 400 x 600	Connecting Power (kW)
BTP 20GLG	2	1408 x 790 x 880	1270	16	0,28
BTP 30GLG	3	1947 x 790 x 880	1270	24	0,34
BTP 40GLG	4	2486 x 790 x 880	1270	32	0,39



## Electronic controls for BFA-BFC

### Use

- Visual information on display
- Manual mode
- Possible manual change in the program during use
- Automatic mode, possible to save up to 30 cycles
- Easy programming of each stage of the cycle
- The use of the "unloading procedure" key stops the ventilators before the door opening, to avoid outside air intake to avoid frost build-up
- Automatic management of end of cycle day
- Fault management
- Antishock, watertight & smooth surface key board

### The advantages

- Automatic management of proofing cycles
- Temperature management
- Manual and automatic mode
- 30 cycles pre-memorized
- Automatic management of the end of cycle day
- Fault management

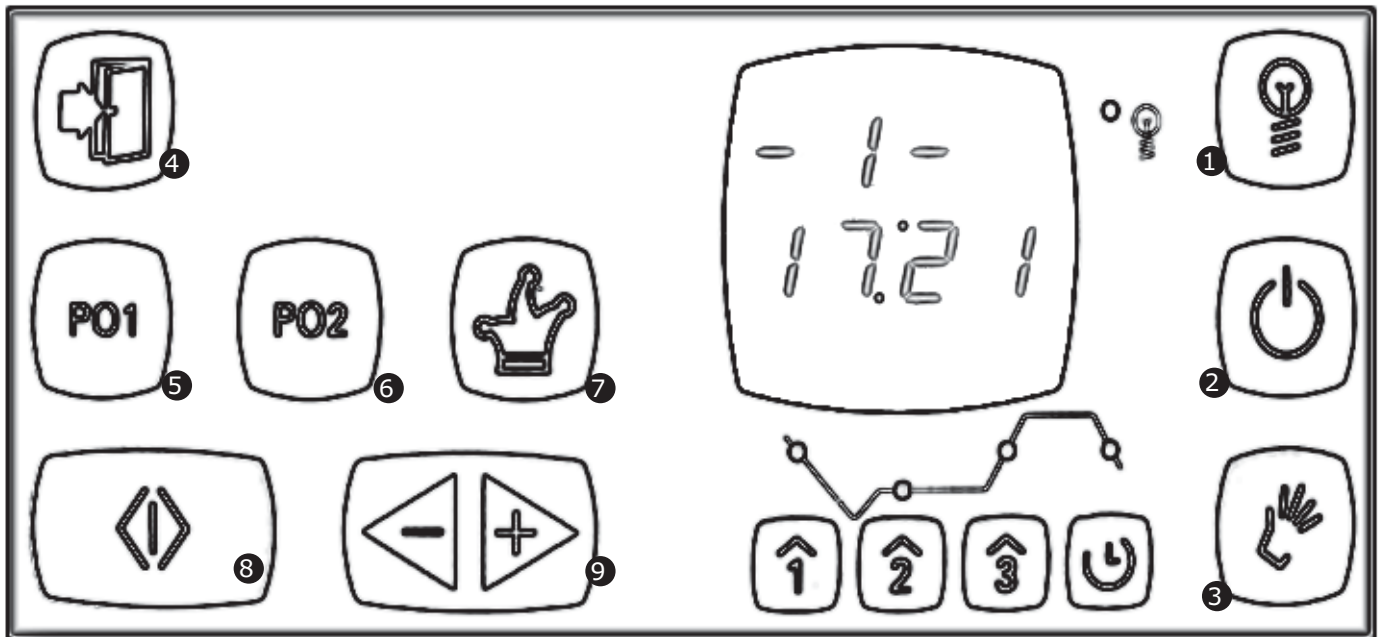

- ① Lighting key (on/off)
- ② On/Off key,
- ③ Manual mode
- ④ Unloading procedure
- ⑤ Direct access "PO1" favourite program
- ⑥ Direct access "PO2" favourite program
- ⑦ « Joker » key
- ⑧ Start/Stop cycle key
- ⑨ Modifications key +/-
- ⑩ Pre cooling key
- ⑪ Retarding key
- ⑫ Proofing key
- ⑬ Setting key day/time



## Electronic controls for BSC-BCP

### Use

- Visual information on display
- Manual mode
- Possible manual change in the program during use
- Automatic mode
- Manual defrosting possible
- Timer mode
- Electronic pin sensor mode
- Fault management
- Antishock watertight & smooth surface key board

### The advantages

- Automatic management of blast freezing & conservation cycles, depending on equipment
- Temperature management
- Manual and automatic mode
- Automatic management of the end of cycle day
- Fault management

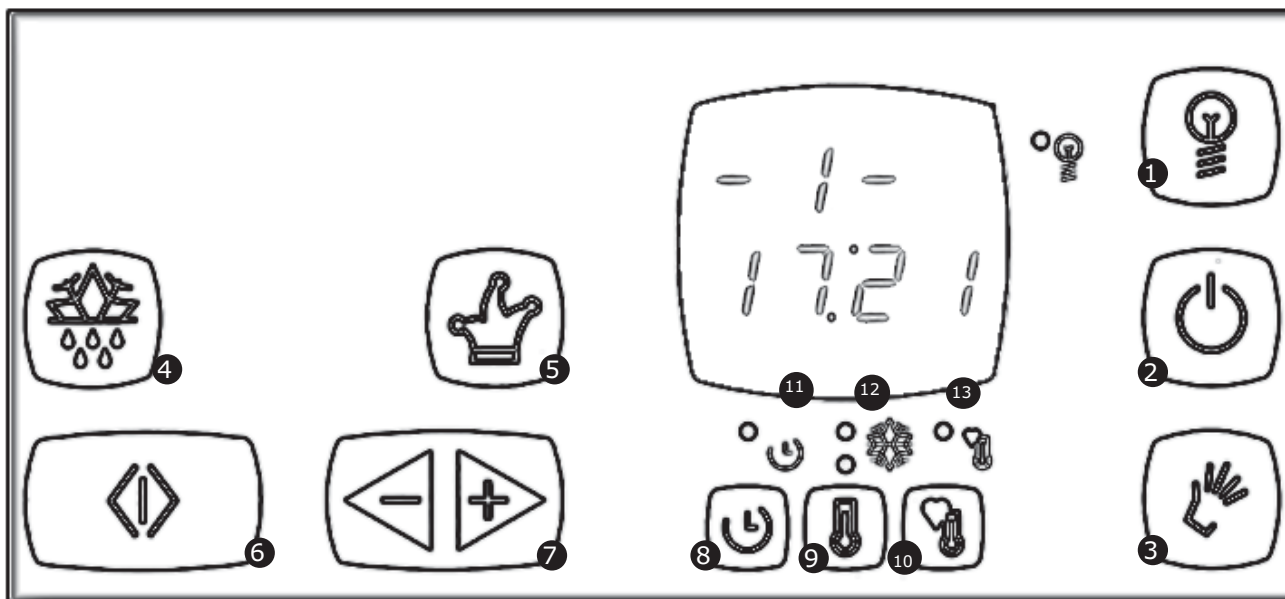

- ① Lighting key (on/off)
- ② On/Off key,
- ③ Manual mode
- ④ Manual defrosting key
- ⑤ « Joker » key
- ⑥ Start/Stop cycle key
- ⑦ Modifications key +/-
- ⑧ Blast freezing : timer mode, display of blast freezing time & temperature of sensors
- ⑨ Conservation setting key
- ⑩ Blast freezing / Pin type mode
- ⑪ Blast freezing Timer Mode "in process"
- ⑫ 1 led : Blast chilling mode  
2 leds : Blast freezing mode
- ⑬ Blast freezing Pin type mode "in process"

# Electromechanical Controls



Electromechanical control for retarding + proofing equipment



Electromechanical control for conservation equipment



Electromechanical control for blast freezing equipment

## Electromechanical interface

### The advantages

- Visual information on unit's functioning
- Manual control of the temperatures & working cycles

### Electromechanical interface - for retarding & proofing equipment

#### Use

- Visual information on display unit
- 2 modes of functioning
  - retarding mode (with timer)
  - proofing mode (without timer)
- Automatic transition from one to another
- Possibility to change information during the cycle

### Electromechanical interface - for blast freezing equipment

#### Use

- Visual information on display unit
- 2 cycle temperatures
  - blast chilling in positive temperatures from +2°C to +10°C
  - blast freezing in negative temperatures from -18°C to -35°C
- 2 modes of functioning
  - timer mode
  - Pin type sensor mode
- Manual defrosting when door is open

### Electromechanical controls - For conservation equipment

#### Use

- Visual information on unit's functioning
- Manual control of the conservation temperature
- Automatic defrosting (4 times a day)
- Manual defrosting possible

## Electromechanical controls for **retarding & proofing equipment**

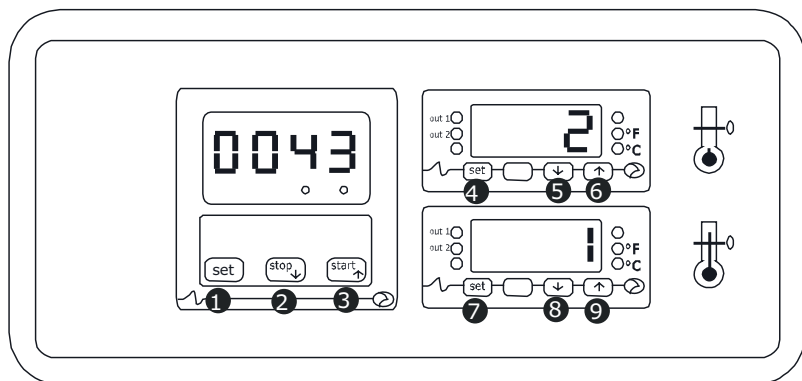

### TIMER FOR RETARDING MODE

- ① Selection of timer
- ② + ③ Modification keys (minute-hour +/-)

### RETARDING DISPLAY

- ④ Selection of RETARDING temperatures
- ⑤ + ⑥ Modification keys (degrees +/-)

### FERMENTATION DISPLAY

- ⑦ Selection of fermentation temperatures
- ⑧ + ⑨ Modification keys (degrees +/-)

## Electromechanical control for **blast freezing equipment**

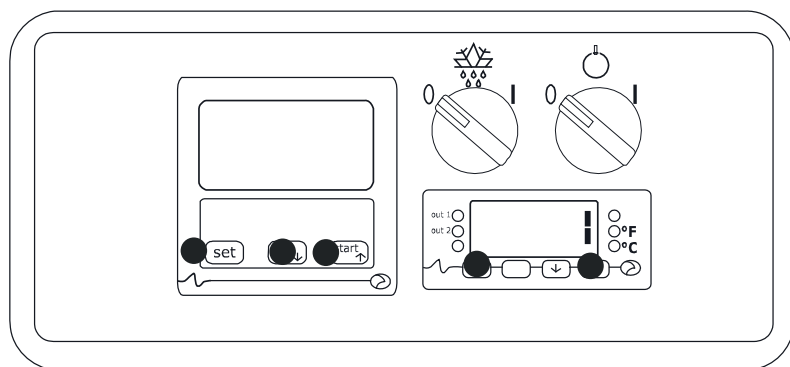

- ① Validation
- ② Selection of functioning modes / Decrease of temperature and/or of blast freezing time
- ③ Increase of temperature and/or of blast freezing time
- ④ Manual defrosting button
- ⑤ On/off button

## Electromechanical control for **Conservation equipment**

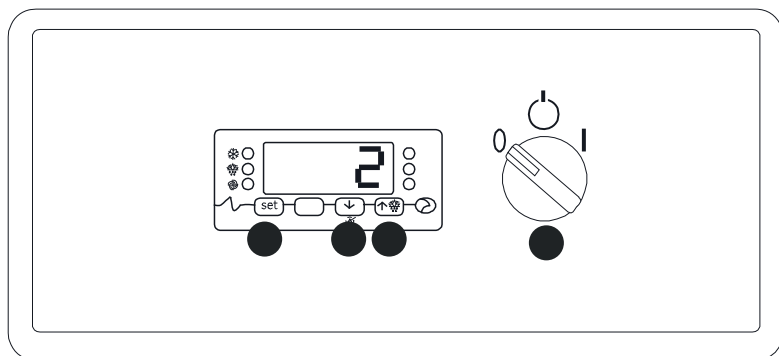

- ① Setting of conservation temperature
  - ② + ③ Modification keys (degrees +/-)
  - ④ On/off button
- ### MANUAL DEFROSTING ACTIVATION
- ③ Manual defrosting button (press for 4 seconds)



## Ambient Air Bread Cooler / Combined Ambient & Cold Air Bread Cooler

### Characteristics

- Ambient air bread cooler model:
  - 2 and 4 racks 600x800 mm
- Combined Ambient & Cold Air Bread Cooler model:
  - 4 racks 600x800 mm only

### The advantages

- Improves the final quality of the product: crispness preserved
- Limits increase in temperature in the bakery
- Optimisation of bread cooling time
- Optimisation of cooling before blast-freezing
- Improves the slicing and packaging rate
- Fewer baking trays immobilised

### Use

The Bongard bread cooler has been developed for cooling to room temperature still warm bakery products.

### Operating principle

The rack is placed in the bread cooler immediately after it is taken out of the rack oven.

The ventilation system propels the air through the trolley. Simultaneously, an extractor located on top on the opposite side collects the hot air loaded with moisture.

Once the first ambient air cooling phase is complete, the trolley is placed in the refrigerated compartment. The evaporators combined with the fans create a refrigerated cold air flow that lowers the temperature of the products.

Once a temperature of 25°C is reached, the trolley can be removed from the bread cooler and the products bagged for sale.

### Construction

- 60 mm thick isothermal panels.
- Compartment constituted by modular panels assembled by eccentric hooks
- Panels injected with polyurethane foam, of a density of 42 kg / m<sup>3</sup>
- Stainless steel coating 6/10 304 thickness inside and 6/10 electro zined steel coated with a protective food grade PVC of 120 micron thick exterior
- Plain doors, same material as panels.
- Wall panels fitted into a base frame made of PVC of 30 mm height fixed to the floor
- Connecting power:
  - ~230V 50-60 Hz without refrigerated unit
  - 3N ~400V 50-60 Hz with refrigerated unit



# Ambient Air Bread Cooler / Combined Ambient & Cold Air Bread Cooler **Zephyr**

<i>Bread cooler</i>	<i>2 racks</i>	<i>4 racks</i>
<b>Capacity</b>		
Number of baking racks 600x800	2	4
<b>Control</b>		
Electromechanical	■	■
<b>Finish on panels and doors</b>		
Inside stainless steel/Outside in PVC-coated steel	■	■
<b>Cooling technology</b>		
By ambient air	■	■
By combination (ambient and cold air)	❖	€
<b>Refrigeration units</b>		
Standard condensing unit (only for combined model)	❖	■
Other types	❖	Ask us
Connected to central unit	❖	Ask us
<b>Miscellaneous</b>		
Stainless steel protection rail	■	■
PVC strip curtain between compartments (only for combined model)	❖	■
<b>Connection</b>		
~230V 50-60 Hz (1 PH) for ambient air model	■	■
3N~400V 50-60Hz (3 PH) for combined model	❖	■

<i>General features</i>		<i>Number of rack 600x800</i>		
		<i>2 racks</i>	<i>4 racks</i>	<i>4 racks</i>
<b>Cooling technology</b>				
Technology		Ambient air		Combination (ambient & cold air)
<b>Extractor</b>				
Number		1	2	1
Diameter (Ø)		200	200	200
<b>Dimensions</b>				
Overall height	(mm)	2560	2560	2670
Front height	(mm)	2100	2100	2220
Overall width	(mm)	1550	1550	1550
Floor depth	(mm)	1750	3350	3350
Overall depth (from door to door)	(mm)	1870	3470	3470
Depth (opened doors)	(mm)	3990	5590	5590
<b>Refrigerated unit</b>				
Available liquid refrigerants		-	-	R448A
Refrigeration power ( at -10/+32°C)	(W)	-	-	3810
<b>Connecting power</b>				
Power supply	(kW)	1	2	8

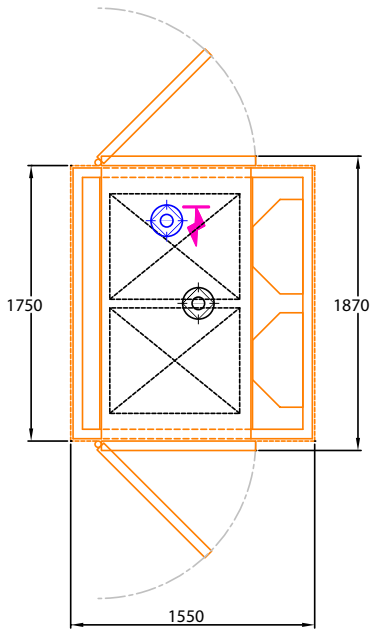

Ambient air model  
2 racks

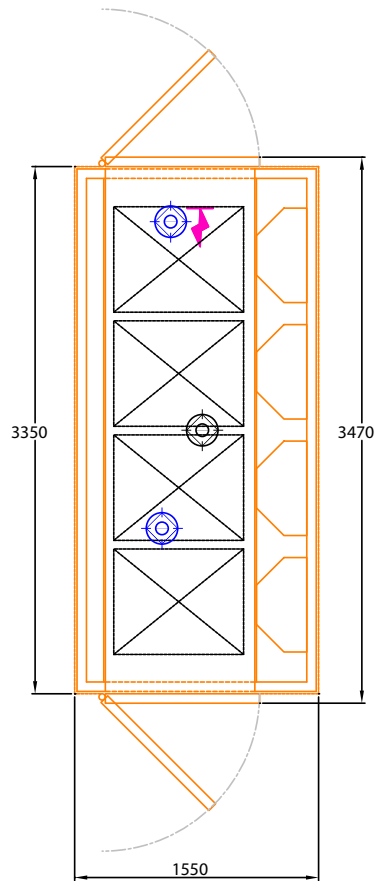

Ambient air model  
4 racks

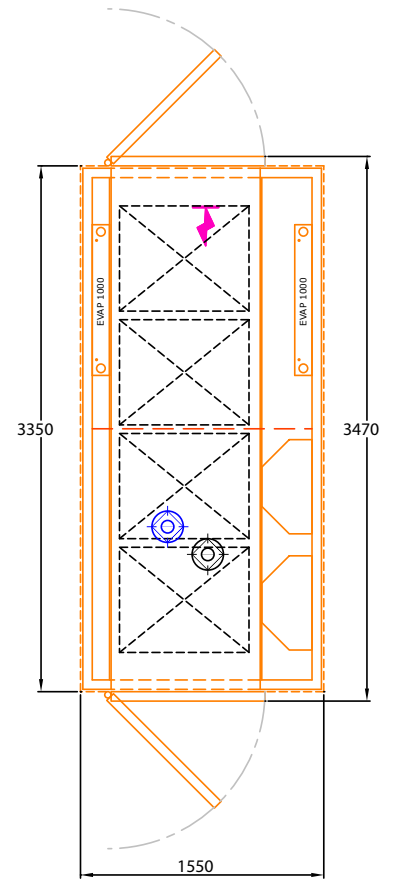

Combination  
(ambient & cold air) model  
4 racks

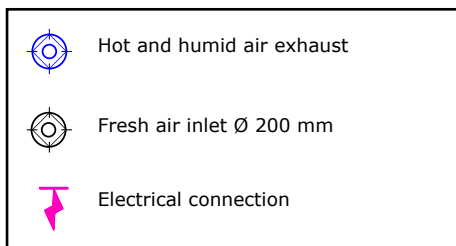

# 6.43 E



## Rotating rack oven - Electric

### Performances

- For tray size : 400 x 600 mm
- 108 short baguettes of 200g or 150 rolls of 60 g on 18 levels

### Accessories

- Rack features: see rack data sheet
- Baking tray features: see baking tray data sheet

### The advantages

- The most compact oven in the range
- Guaranteed homogeneous & uniform baking
- Fitted with «soft pulse» technology for gentle and effective ventilation
- Ideal for baking bread and pastry products, even the lightest
- New heat exchanger for improved profitability
- Safety clutch on the rack drive

### Use

6.43 E is an electric rotating rack oven designed for pastry shops and bakers. Multipurpose, it can bake the most delicate products. Very compact, it even finds a place in the most cramped bakeries.

### Operating principle

The suspended rack or the rack carried by the oven's turntable (depending on the model), is crossed by a flow of hot air. The balanced ventilation speed, mass and radiation ensure optimal baking. Specific Bongard steam generators produce high quality steam, in sufficient quantity for the whole height of the rack. A gentle ventilation distributes an even heat without drying the product.

### Construction

- **Front**
  - polished stainless steel
  - tool holder
  - blade holder
  - control panel protection bumper
  - circuit breaker
- **Baking chamber**
  - Stainless steel baking chamber
  - adjustable air flow louvers
  - halogen lighting
  - driven by gear motor with torque reducer
- **Heat exchanger**
  - high performance stainless steel heat exchanger
  - high performance S/S electric heating elements
- **retractable access ramp for a perfect and durable door tightness**
- **Door**
  - 150 mm with double anchoring
  - door seals on 4 sides
  - over-dimensioned hinges
  - removable ventilated double-glazing
  - Ergonomic handle
- **steam generator**
  - steam generator composed of structured gutters in cast-iron
  - multi-level injection pipe
- **Steam vent**
  - 2 electric steam dampers
  - programmable steam evacuation
- **Performant insulation by crossed rock wool panels**

## Rotating rack oven **6.43 E**

<i>Model</i>	<i>France</i>	<i>Export</i>
<b>Drive system</b>		
Turntable	■	■
Hook	□	□
<b>Heating elements</b>		
Access on the left	■	■
Access on the right	□	□
<b>Door handle and control panel</b>		
Left	■	■
Right	□	□
<b>Controls</b>		
Electronic controls Opticom	■	■
Electromechanical with deferred start-up timer	€	€
<b>Headband - Hood - Exhaust fan</b>		
Headband	■	■
Hood with exhaust fan	€	€
<b>Additional options</b>		
Pulsed steam injection	■	■
Brass water solenoid valve	❖	■
Water filter to prevent scale deposits	€	€
Pressure reducing valve kit	■	■
<b>Electrical supply</b>		
3N~400V	■	■

<b>Power features</b>		
<b>Electric power</b>		
Total connecting power	(A)	63
Exhaust fan connecting power	(kW)	0,18
Heating power	(kW)	36
Average gradient of temperature rise	°C/min	10-12
Maximum baking temperature of the oven	°C	280

# Rotating rack oven 6.43 E

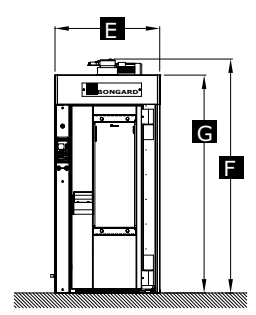
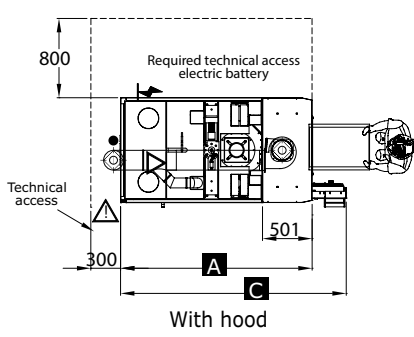
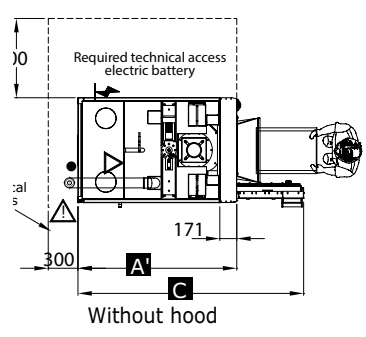
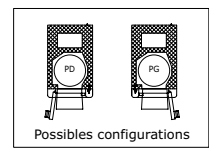
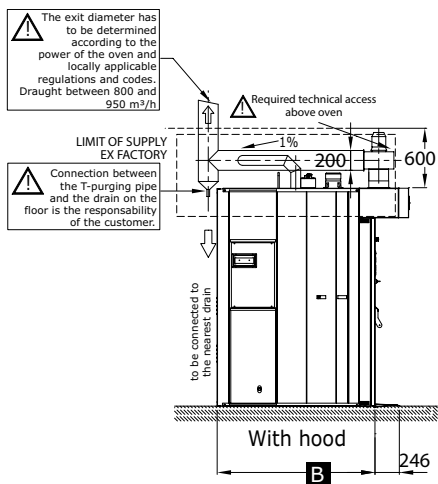
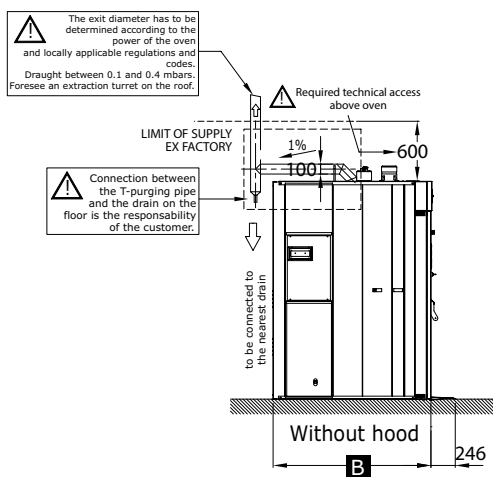

Dimensional features			
<b>Oven dimensions</b>			
<b>A</b>	Depth with hood	(mm)	1933
<b>A'</b>	Depth with headband	(mm)	1603
<b>B</b>	Depth on the floor	(mm)	1594
<b>C</b>	Depth (door opened)	(mm)	2279
<b>E</b>	Width on the floor	(mm)	1061
<b>F</b>	Total height, overall	(mm)	2362
<b>G</b>	Total height, oven front	(mm)	2200
	Floor area	(m <sup>2</sup> )	1,95
	Total weight	(kg)	850
<b>Baking chamber</b>			
	Maximum rack height	(mm)	1785
	Maximum rack width	(mm)	460
	Maximum rotation Ø	(mm)	840
	Maximum payload	(kg)	150
<b>Space required to access building site</b>			
	Minimum door clearance	(mm)	580

- Water drain, H=65 mm, Ø 3/4".
- ⚡ Electrical connection from the ceiling direct to the electrical power supply panel at base of oven.
- ▽ Water connection from the ceiling + stop valve Ø 3/8"-12/14 mm, pressure: 2.5-4 bars
- ⊙ Steam exhaust duct, Ø 100 mm. Draught between 0.1-0.4 mbars. Oven with steam exhaust hood: steam duct Ø 200 mm. Extraction between 800-950 m³/h or 28252-33550 ft³/h.

■ **Important note :**  
 Required technical access above oven: 600 mm  
 Required technical access (electric heating battery): 800 mm

# 6.43 MG



## Rotating rack oven - Fuel-oil / Gas

### Performances

- For tray size : 400 x 600 mm
- 108 short baguettes of 200g or 150 rolls of 60 g on 18 levels

### Accessories

- Rack features: see rack data sheet
- Baking tray features: see baking tray data sheet

### The advantages

- The most compact oven in the range
- Guaranteed homogeneous & uniform baking
- Fitted with «soft pulse» technology for gentle and effective ventilation
- Ideal for baking bread and pastry products, even the lightest
- New heat exchanger for improved profitability
- Safety clutch on the rack drive

### Use

6.43 MG is a rotating rack oven, Fuel-Oil or Gas heated, designed for pastry shops and bakers. Multipurpose, it can bake the most delicate products. Very compact, it even finds a place in the most cramped bakeries.

### Operating principle

The suspended rack or the rack carried by the oven's turntable (depending on the model), is crossed by a flow of hot air. The balanced ventilation speed, mass and radiation ensure optimal baking. Specific Bongard steam generators produce high quality steam, in sufficient quantity for the whole height of the rack. A gentle ventilation distributes an even heat without drying the product.

### Construction

- **Front**
    - polished stainless steel
    - tool holder
    - blade holder
    - control panel protection bumper
    - circuit breaker
  - **Baking chamber**
    - Stainless steel baking chamber
    - adjustable air flow louvers
    - halogen lighting
    - driven by gear motor with torque reducer
  - **Heat exchanger**
    - high performance refractory stainless steel heat exchanger
  - **Retractable access ramp for a perfect and durable door tightness**
  - **Door**
    - 150 mm with double anchoring
    - door seals on 4 sides
    - over-dimensioned hinges
    - removable ventilated double-glazing
    - Ergonomic handle
  - **Steam generator**
    - steam generator composed of structured gutters in cast-iron
    - multi-level injection pipe
  - **Steam vent**
    - 2 electric steam dampers
    - programmable steam evacuation
- Performant insulation by crossed rock wool panels**

## Rotating rack oven **6.43 MG**

<b>Model</b>	<b>France</b>	<b>Export</b>
<b>Drive system</b>		
Turntable	■	■
Hook	□	□
<b>Burner</b>		
Gas burner	■	■
fuel-oil burner	□	□
Access burner on the left	■	■
Access burner on the right	□	□
<b>Door handle and control panel</b>		
Left	■	■
Right	□	□
<b>Controls</b>		
Electronic controls Opticom	■	■
Electromechanical controls with deferred start-up timer	€	€
<b>Headband - Hood - Exhaust fan</b>		
Headband	■	■
Hood with exhaust fan	€	€
<b>Additional options</b>		
Pulsed steam injection	■	■
Brass water solenoid valve	❖	■
Water filter to prevent scale deposits	€	€
Fresh air inlet on burner	■	■
Pressure reducing valve kit	■	■
<b>Electrical supply</b>		
~230V	■	■

<b>Power features</b>		
<b>Electric power</b>		
Total connecting power	(A)	16
Exhaust fan connecting power	(kW)	0,18
Heating power	(kW)	45
Average gradient of temperature rise	°C/min	8-10
Maximum baking temperature of the oven	°C	280

# Rotating rack oven 6.43 MG

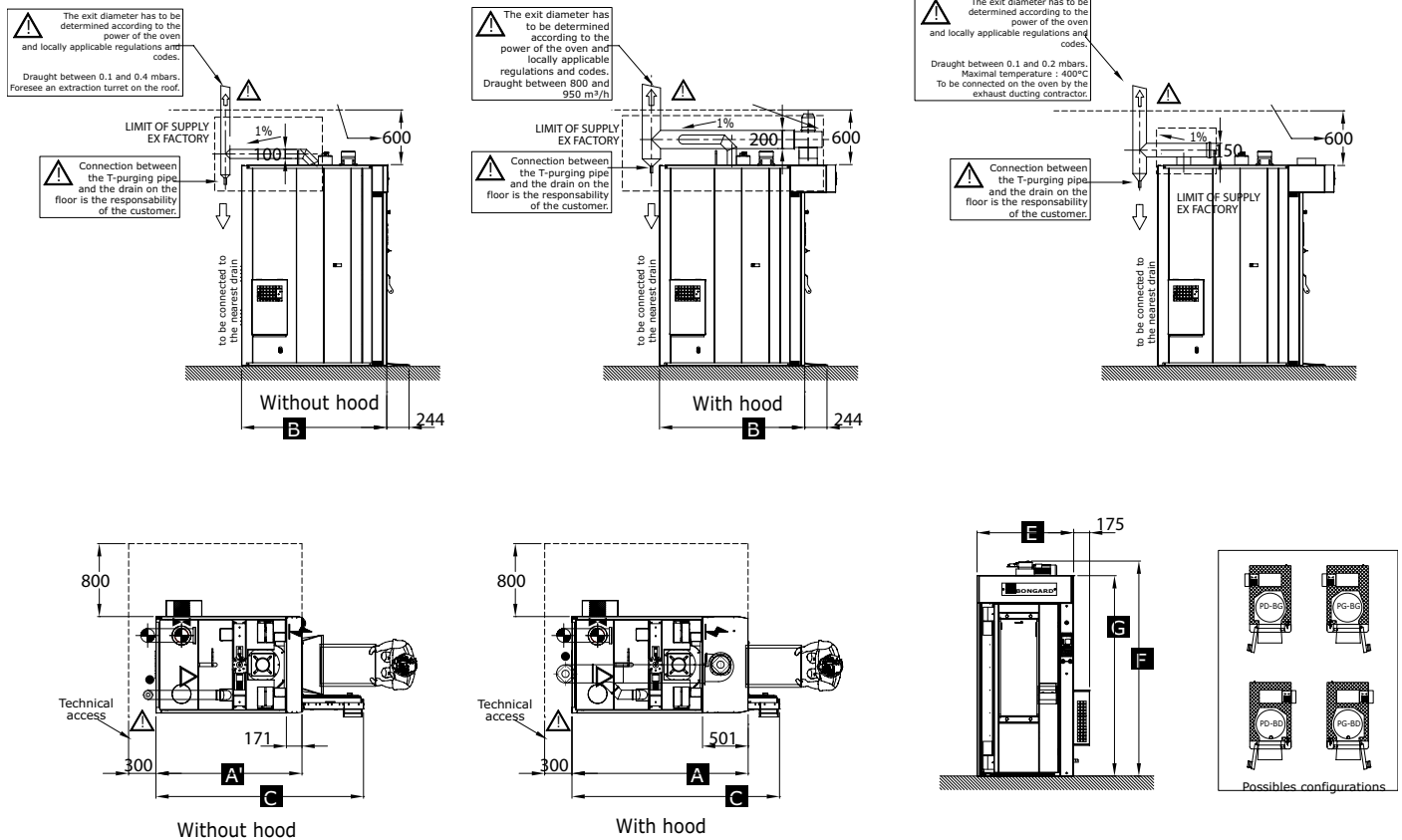

Dimensional features			
<b>Dimensionnels four</b>			
<b>A</b>	Depth with hood	(mm)	1933
<b>A'</b>	Depth with headband	(mm)	1603
<b>B</b>	Depth on the floor	(mm)	1594
<b>C</b>	Depth (door opened)	(mm)	2279
<b>E</b>	Width on the floor	(mm)	1061
<b>F</b>	Total height, overall	(mm)	2430
<b>G</b>	Total height, oven front	(mm)	2200
	Floor area	(m <sup>2</sup> )	1,95
	Total weight	(kg)	850
<b>Baking chamber</b>			
	Maximum rack height	(mm)	1785
	Maximum rack width	(mm)	460
	Maximum rotation Ø	(mm)	840
	Maximum payload	(kg)	150
<b>Space required to access building site</b>			
	Minimum door clearance	(mm)	580

- Water drain, H=65 mm, Ø 3/4".
- ⚡ Electrical connection from the ceiling direct to the electrical power supply panel at base of oven.
- ⚡ Gas connection 3/4" or fuel connection 10/12 for the burner with cut off valve.
- ▽ Water connection from the ceiling + stop valve. Ø 3/8"-12/14 mm, pressure : 2.5-4 bars
- ⊕ Steam exhaust duct Ø 100 mm. Draught between 0.1-0.4 mbars. Oven with steam exhaust hood: steam duct Ø 200 mm. Extraction between 800-950 m<sup>3</sup>/h or 28252-33550 ft<sup>3</sup>/h.
- ⊕ Steam exhaust, Ø 150 mm. Draught between 0.1-0.2 mbars.
- Fresh air inlet for the burner stainless steel 200 x 200 mm.

### ••• Important note :

Required technical access above oven: 600 mm  
 Required technical access (heat exchanger): 800 mm



# 8.43 FE



Oven  
supplied  
disassembled

## Static rack oven - Electric

### Performances

- Rack oven for 460 x 800 or 400 x 800 mm tray size
- 90 baguettes of 250 g on 15 levels
- 60 loaves of 400 g on 15 levels

### Accessories

- Rack features: see rack data sheet
- Baking tray features: see baking tray data sheet

### The advantages

- 460x800 oven, the most compact in the range
- Effective ventilation
- 3 inverted-flow turbines guarantee good distribution of hot air
- 150 mm thick door and oversized hinges for extreme toughness

### Use

8.43 FE is an electric rotating rack designed for pastry shops and bakers. Multipurpose, it can bake the most delicate products. Very compact, it even finds a place in the most cramped bakeries.

### Operating principle

Ventilated from the rear, hot air projected by 3 inverted air flow turbines is swept through the rack, guaranteeing controlled baking. Steam generators throughout the height of the rack guaranteeing high quality steam, in sufficient quantity for the whole baking cycle.

### Construction

- **Front**
  - Polished stainless steel
  - Tool holder
  - Blade holder
  - Control panel protection bumper
  - Circuit breaker
- **Baking chamber**
  - Stainless steel baking chamber
  - High performance stainless steel heating elements
- **Retractable access ramp for a perfect and durable door tightness**
- **Door**
  - 150 mm with double anchoring
  - Door seals on 4 sides
  - Over-dimensioned hinges
  - Removable ventilated double-glazing
  - Ergonomic handle
- **steam generator**
  - Steam generator composed of structured gutters in cast-iron
  - Multi-level injection pipe
- **Steam vent**
  - 2 electric steam dampers
  - Programmable steam evacuation
- **Performant insulation by crossed rock wool panel**

## Static rack oven - Electric **8.43 FE**

<i>Model</i>	<i>France</i>	<i>Export</i>
<b>Energie</b>		
Electrique	■	■
<b>Door handle and control panel</b>		
Left	■	■
Right	□	□
<b>Controls</b>		
Electronic controls Opticom	■	■
<b>Headband - Hood - Exhaust fan</b>		
Headband	■	■
Hood	€	€
Exhaust fan	€	€
<b>Additional options</b>		
Pulsed steam injection	■	■
Brass water solenoid valve	❖	■
Water filter to prevent scale deposits	€	€
Pressure reducing valve kit	■	■
<b>Electrical supply</b>		
3N~400V	■	■

<b>Power features</b>		
<b>Electric power</b>		
Total connecting power	(A)	63
Exhaust fan connecting power	(kW)	0,18
Heating power	(kW)	36
Average gradient of temperature rise	°C/min	10-12
Maximum baking temperature of the oven	°C	280

# Static rack oven - Electric 8.43 FE

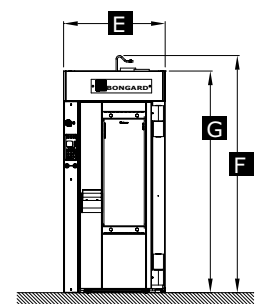
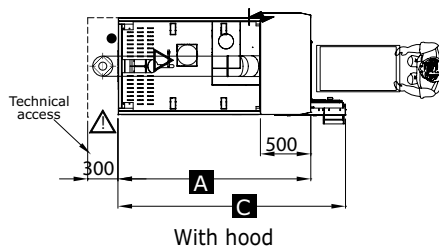
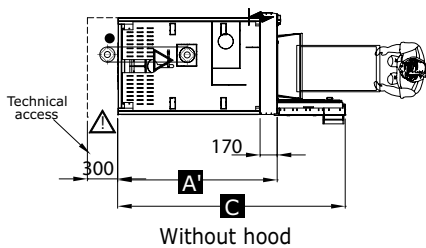
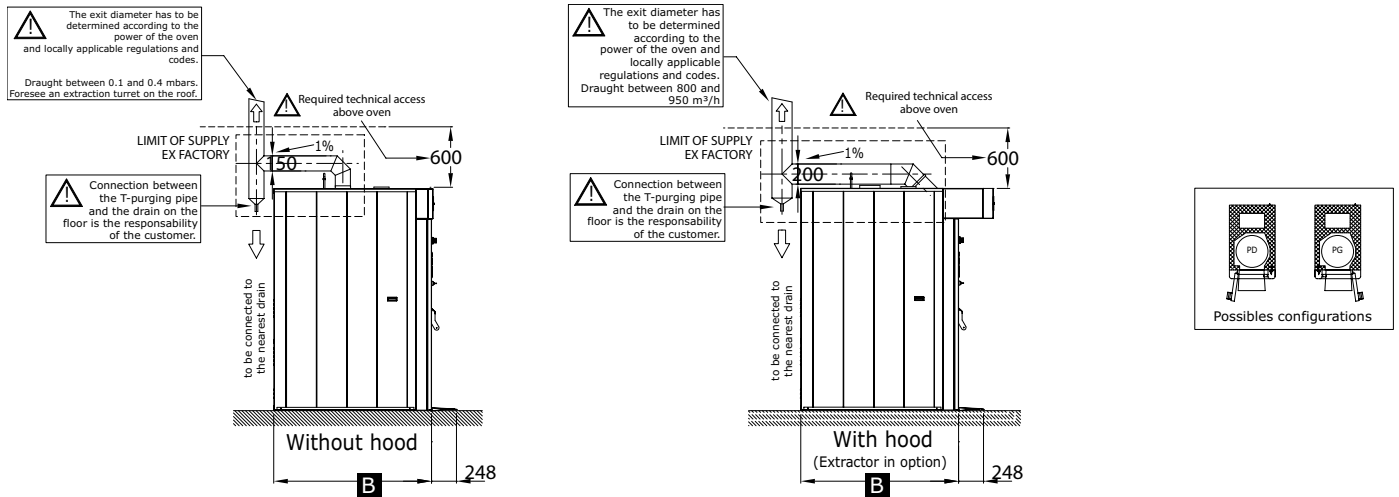

Dimensional features			
Oven dimensions			
<b>A</b>	Depth with hood	(mm)	1910
<b>A'</b>	Depth with headband	(mm)	1580
<b>B</b>	Depth on the floor	(mm)	1566
<b>C</b>	Depth (door opened)	(mm)	2256
<b>E</b>	Width on the floor	(mm)	1009
<b>F</b>	Total height, overall	(mm)	2354
<b>G</b>	Total height, oven front	(mm)	2200
	Floor area	(m <sup>2</sup> )	1,5
	Total weight	(kg)	750
Baking chamber			
	Maximum rack height	(mm)	1800
	Maximum rack width	(mm)	525
	Maximum rotation Ø	(mm)	-
	Maximum payload	(kg)	200
Space required to access building site			
	Minimum door clearance (assembled)	(mm)	1010
	Minimum door clearance (disassembled in factory)	(mm)	870
	Minimum door clearance (disassembled on site)	(mm)	780

- Water drain, H=65 mm, Ø 3/4".
- ⚡ Electrical connection from the ceiling direct to the electrical power supply panel at base of oven.
- ▽ Water connection from the ceiling + stop valve. Ø 3/8"-12/14 mm, pressure : 2.5-4 bars
- ⊙ Steam exhaust duct Ø 150 mm. Draught between 0.1-0.4 mbars. Oven with steam exhaust hood: steam duct Ø 200 mm. Extraction between 800-950 m<sup>3</sup>/h or 28252-33550 ft<sup>3</sup>/h.

## ••• Important note :

Required technical access above oven: 600 mm

# 8.43 E



## Rotating rack oven - Electric

### Performances

- Rack oven for 400 x 800 or 460 x 800 mm tray size
- 108 baguettes of 250 g or 200 rolls of 60 g on 18 levels
- 60 loaves of 400 g on 15 levels

### Accessories

- Rack features: see rack data sheet
- Baking tray features: see baking tray data sheet

### The advantages

- Ideal for baking bread and pastry products
- 150 mm thick door and oversized hinges for extreme toughness
- Safety clutch on the rack drive

### Use

6.43 E is an electric rotating rack designed for pastry shops and bakers. Multipurpose, it can cook the most delicate products. Very compact, it even finds a place in the most cramped bakeries.

### Operating principle

The suspended rack or the rack carried by the oven's turntable (depending on the model), is crossed by a flow of hot air. The balanced ventilation speed, mass and radiation ensure optimal baking. Specific Bongard steam generators produce high quality steam, in sufficient quantity for the whole height of the rack. A gentle ventilation distributes an even heat without drying the product.

### Construction

- **Front**
  - polished stainless steel
  - tool holder
  - blade holder
  - control panel protection bumper
  - circuit breaker
- **Baking chamber**
  - Stainless steel
  - adjustable air flow louvers
  - halogen lighting
  - driven by gear motor with torque reducer
  - high performance stainless steel heating elements
- **Retractable access ramp for a perfect and durable door tightness**
- **Door**
  - 150 mm with double anchoring
  - door seals on 4 sides
  - over-dimensioned hinges
  - removable ventilated double-glazing
  - ergonomic handle
- **Steam generator**
  - steam generator composed of structured gutters in cast-iron
  - multi-level injection pipe
- **Steam vent**
  - 2 electric steam dampers
  - programmable steam evacuation
- **Insulation**
  - Performant insulation by crossed rock wool panel

## Rotating rack oven **8.43 E**

<b>Model</b>	<b>France</b>	<b>Export</b>
<b>Drive system</b>		
Turntable	■	■
Hook	□	□
<b>Door handle and control panel</b>		
Left	■	■
Right	□	□
<b>Controls</b>		
Electronic controls Opticom	■	■
Eletromechanical controls with deferred start-up timer	€	€
<b>Headband - Hood - Exhaust fan</b>		
Headband	■	■
Hood	€	€
Exhaust fan	€	€
<b>Additonal options</b>		
Pulsed steam injection	■	■
Ventilation 2 speeds	€	€
Reinforced ventilation 3 turbines	❖	■
Brass water solenoid valve	❖	■
Water filter to prevent scale deposits	€	€
Pressure reducing valve kit	■	■
<b>Electrical supply</b>		
3N~400V	■	■

<b>Power features</b>		
<b>Electric power</b>		
Total connecting power	(A)	63
Exhaust fan connecting power	(kW)	0,18
Heating power	(kW)	36
Average gradient of temperature rise	°C/min	10 - 12
Maximum baking temperature of the oven	°C	280

# Rotating rack oven 8.43 E

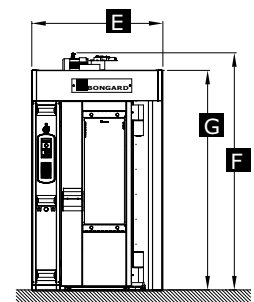
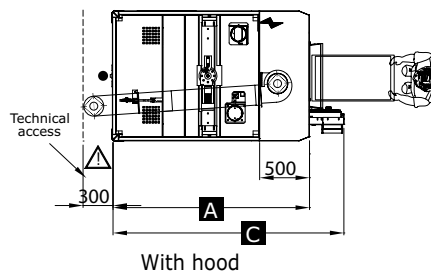
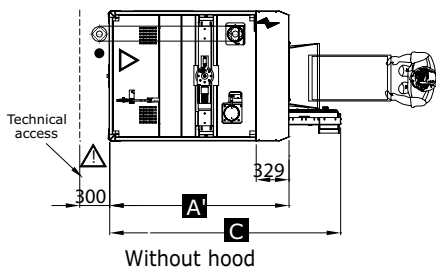
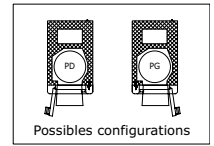
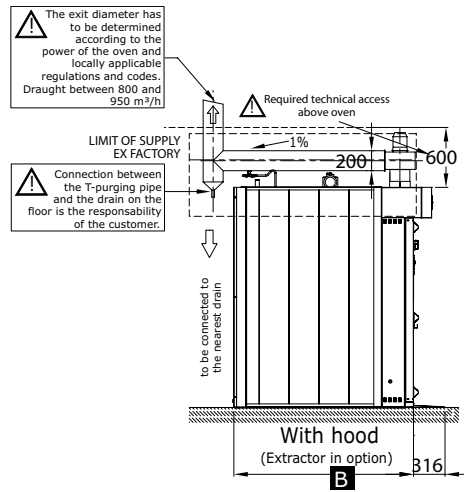
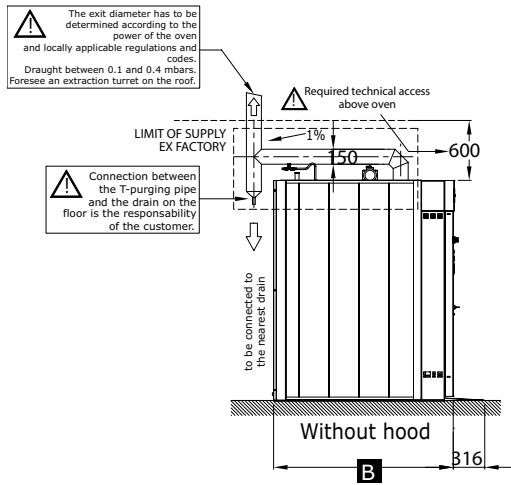

## Dimensional features

### Oven dimensions

A	Depth with hood	(mm)	1973
A'	Depth with headband	(mm)	1801
B	Depth on the floor	(mm)	1791
C	Depth (door opened)	(mm)	2320
E	Width on the floor	(mm)	1300
F	Total height, overall	(mm)	2388
G	Total height, oven front	(mm)	2200
	Floor area	(m <sup>2</sup> )	2,3
	Total weight	(kg)	940
<b>Baking chamber</b>			
	Maximum rack height	(mm)	1785
	Maximum rack width	(mm)	575
	Maximum rotation Ø	(mm)	940
	Maximum payload	(kg)	200
<b>Space required to access building site</b>			
	Minimum door clearance	(mm)	980

- Water drain, H=65 mm, Ø 3/4".
- ⚡ Electrical connection from the ceiling direct to the electrical power supply panel at base of oven.
- ▽ Water connection from the ceiling + stop valve. Ø 3/8"-12/14 mm, pressure : 2.5-4 bars
- ⊙ Steam exhaust duct Ø 150 mm. Draught between 0.1-0.4 mbars. Oven with steam exhaust hood: steam duct Ø 200 mm. Extraction between 800-950 m<sup>3</sup>/h or 28252-33550 ft<sup>3</sup>/h.

### ••• Important note:

Required technical access above oven: 600 mm

# 8.43 MG



## Rotating rack oven - Fuel-oil / Gas

### Performances

- Rack oven for 400 x 800 or 460 x 800 mm tray size
- 108 baguettes of 250 g or 200 rolls of 60 g on 18 levels
- 60 loaves of 400 g on 15 levels

### Accessories

- Rack features: see rack data sheet
- Baking tray features: see baking tray data sheet

### The advantages

- Ideal for baking bread and pastry products
- Rear heat exchanger guaranteeing even baking all day long
- 150 mm thick door and oversized hinges for extreme toughness
- Safety clutch on the rack drive

### Use

8.43 MG is a fuel-oil or gas-heated rotating rack oven with rear heat exchanger for bakers and pastry chefs. Very compact, it even finds a place in the most cramped bakeries.

### Operating principle

The suspended rack or the rack carried by the oven's turntable (depending on the model), is crossed by a flow of hot air. The balanced ventilation speed, mass and radiation ensure optimal baking. Specific Bongard steam generators produce high quality steam, in sufficient quantity for the whole height of the rack. A gentle ventilation distributes an even heat without drying the product.

### Construction

- **Front**
  - polished stainless steel
  - tool holder
  - blade holder
  - control panel protection bumper
  - circuit breaker
- **Baking chamber**
  - Stainless steel
  - adjustable air flow louvers
  - halogen lighting
  - driven by gear motor with torque reducer
- **Heat exchanger**
  - high performance refractory stainless steel heat exchanger
- **Retractable access ramp for a perfect and durable door tightness**
- **Door**
  - 150 mm with double anchoring
  - door seals on 4 sides
  - over-dimensioned hinges
  - removable ventilated double-glazing
  - ergonomic handle
- **Steam generator**
  - steam generator composed of structured gutters in cast-iron
  - multi-level injection pipe
- **Steam vent**
  - 2 electric steam dampers
  - programmable steam evacuation
- **Perforant insulation by crossed rock wool panel**

## Rotating rack oven **8.43 MG**

<b>Model</b>	<b>France</b>	<b>Export</b>
<b>Drive system</b>		
Turntable	■	■
Hook	□	□
<b>Burner</b>		
Gas burner	■	■
Fuel-oil burner	□	□
Access burner on the left	■	■
Access burner on the right	□	□
<b>Door handle and control panel</b>		
Left	■	■
Right	□	□
<b>Controls</b>		
Electronic controls Opticom	■	■
Electromechanical controls with deferred start-up timer	€	€
<b>Headband - Hood - Exhaust fan</b>		
Headband	■	■
Hood	€	€
Exhaust fan	€	€
<b>Additional options</b>		
Pulsed steam injection	■	■
2 speed ventilation	€	€
Brass water solenoid valve	❖	■
Water filter to prevent scale deposits	€	€
Fresh air inlet on burner	■	■
Pressure reducing valve kit	■	■
<b>Electrical supply</b>		
3N~400V	■	■

<b>Power features</b>		
<b>Electric power</b>		
Total connecting power	(A)	16
Exhaust fan connecting power	(kW)	0,18
Heating power	(kW)	60
Average gradient of temperature rise	°C/min	10 - 12
Maximum baking temperature of the oven	°C	280



# Rotating rack oven 8.43 MG

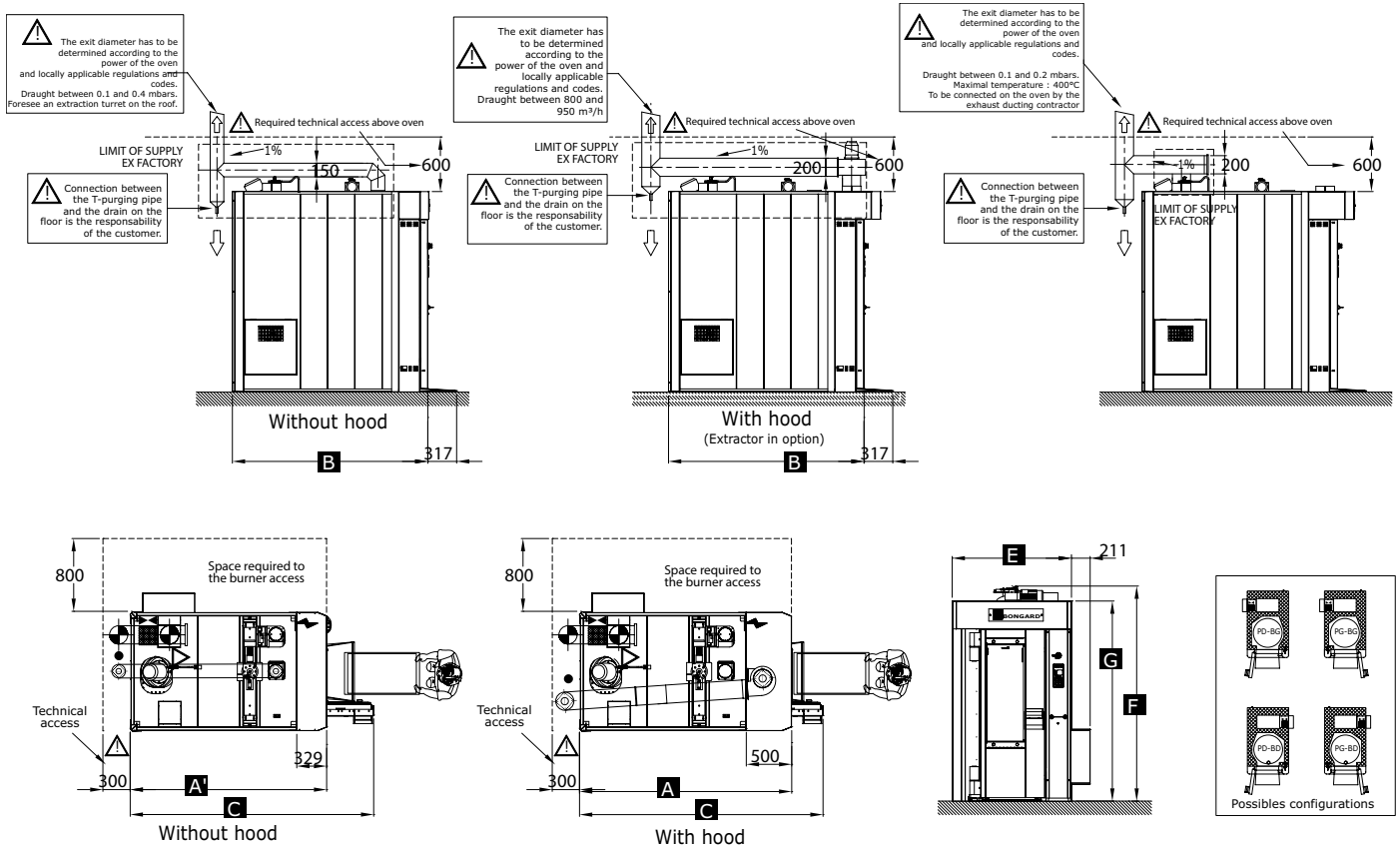

Dimensional features			
Oven dimensions			
<b>A</b>	Depth with hood	(mm)	2323
<b>A'</b>	Depth with headband	(mm)	2152
<b>B</b>	Depth on the floor	(mm)	2141
<b>C</b>	Depth (door opened)	(mm)	2670
<b>E</b>	Width on the floor	(mm)	1300
<b>F</b>	Total height, overall	(mm)	2370
<b>G</b>	Total height, oven front	(mm)	2200
	Floor area	(m <sup>2</sup> )	2,7
	Total weight	(kg)	1150
Baking chamber			
	Maximum rack height	(mm)	1785
	Maximum rack width	(mm)	575
	Maximum rotation Ø	(mm)	955
	Total acceptable payload	(kg)	200
Space required to access building site			
	Minimum door clearance	(mm)	920

- Water drain, H=65 mm, Ø 3/4".
- ⚡ Electrical connection from the ceiling direct to the electrical power supply panel at base of oven.
- ⚡ Gas connection 3/4" or fuel connection 10/12 for the burner with cut off valve.
- ▽ Water connection from the ceiling + stop valve. Ø 3/8"-12/14 mm, pressure : 2.5-4 bars
- ⊙ Steam exhaust duct Ø 150 mm. Draught between 0.1-0.4 mbars. Oven with steam exhaust hood: steam duct Ø 200 mm. Extraction between 800-950 m<sup>3</sup>/h or 28252-33550 ft<sup>3</sup>/h.
- ⊙ Steam exhaust, Ø 200 mm. Draught between 0.1-0.2 mbars.
- Fresh air inlet for the burner stainless steel 200 x 200 mm.

### ••• Important notes :

Required technical access above oven: 600 mm  
 Required technical access (electric battery): 800 mm

# 10.83 E



## Rotating rack oven - Electric

### Performances

- Rack oven for 800 x 1000 mm or 780 x 980 mm tray size or 2 trays 460 x 760 mm per level
- 180 to 216 baguettes of 250 g on 18 levels
- 108 to 135 loaves of 400 g on 15 levels

### Accessories

- Rack features: see rack data sheet
- Baking tray features: see baking tray data sheet

### The advantages

- Oven particularly designed for industrial use
- Large rack payload
- Very high capacity
- Very good energy yield
- High inertia owing to the mass of the lateral heat exchanger
- Oversized front features, door and hinges
- Slow ventilation avoiding drying of products
- Technical accessibility by the front of the oven

### Use

10.83 E is an industrial electric rotating rack oven for bakers, pastry chefs and caterers. Multipurpose and productive, it is designed for large bakeries and industrialists.

### Operating principle

The rack, carried by the turntable, is crossed by a flow of hot air. The balanced ventilation speed, mass and radiation ensure optimal baking. Specific Bongard steam generators produce high quality steam, in sufficient quantity for the whole height of the rack. A gentle ventilation distributes an even heat without drying the product. The massive heat exchanger allows successive baking batches while maintaining an even bake and high productivity.

### Construction

- **Front**
  - polished stainless steel
  - tool holder
  - blade holder
  - control panel protection bumper
  - circuit breaker
- **Baking chamber**
  - Stainless steel
  - adjustable air flow louvers
  - halogen lighting
  - driven by gear motor with torque reducer
- **Heat exchanger**
  - high performance stainless steel heat exchanger
  - high performance S/S electric heating elements
- **Access ramp**
  - retractable access ramp for a perfect and durable door tightness
- **Door**
  - 150 mm with double anchoring
  - door seals on 4 sides
  - over-dimensioned hinges
  - removable ventilated double-glazing
  - ergonomic handle
- **Steam generator**
  - steam generator composed of structured gutters in cast-iron
  - multi-level injection pipe
- **Steam vent**
  - 2 electric steam dampers
  - programmable steam evacuation
- **Insulation**
  - Performant insulation by crossed rock wool panel

## Rotating rack oven **10.83 E**

<i>Modèle</i>	<i>France</i>	<i>Export</i>
<b>Drive system</b>		
Turntable	■	■
<b>Heating elements</b>		
Access to the front	■	■
<b>Door handle and control panel</b>		
Left	■	■
<b>Controls</b>		
Electronic controls Opticom	■	■
Electromechanical controls with deferred start-up timer	€	€
<b>Hood - Exhaust fan</b>		
Hood	■	■
Exhaust fan	€	€
<b>Additional options</b>		
Pulsed steam injection	■	■
Brass water solenoid valve	❖	■
Water filter to prevent scale deposits	€	€
Pressure reducing valve kit	■	■
<b>Electrical supply</b>		
3N~400V	■	■

<b>Power features</b>		
<b>Electric power</b>		
Total connecting power	(A)	125
Exhaust fan connecting power	(kW)	0,18
Heating power	(kW)	65
Average gradient of temperature rise	°C/min	10 - 12
Maximum baking temperature of the oven	°C	280

# Rotating rack oven 10.83 E

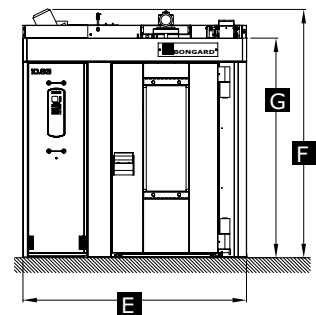
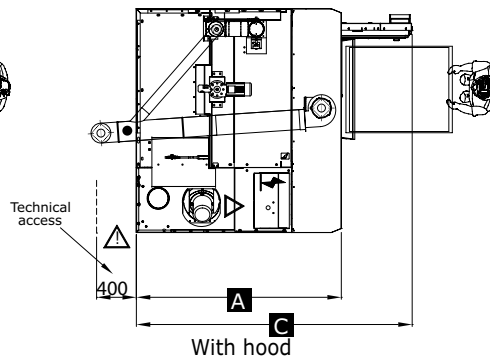
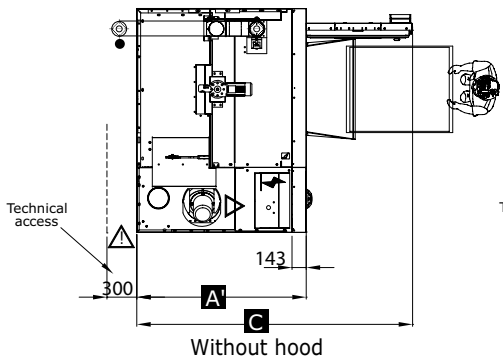
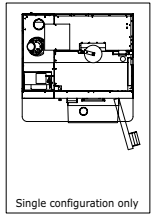
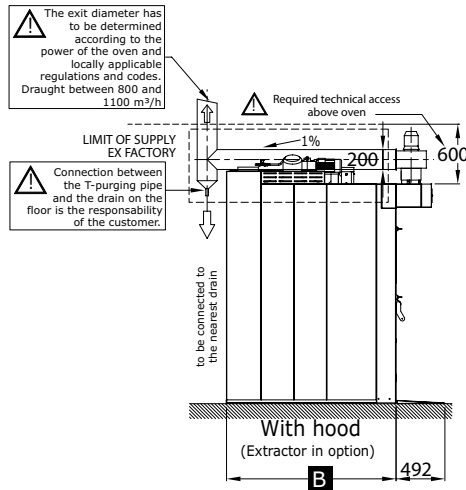
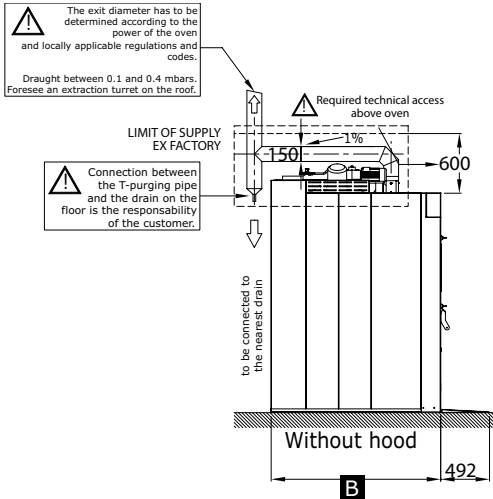

<b>Dimensional features</b>			
<b>Oven dimensions</b>			
<b>A</b>	Depth with hood	(mm)	2062
<b>A'</b>	Depth with headband	(mm)	1705
<b>B</b>	Depth on the floor	(mm)	1705
<b>C</b>	Depth (door opened)	(mm)	2774
<b>E</b>	Width on the floor	(mm)	2251
<b>F</b>	Total height	(mm)	2492
<b>G</b>	Total height, oven front	(mm)	2200
	Floor area	(m <sup>2</sup> )	3,9
	Total weight	(kg)	1830
<b>Baking chamber</b>			
	Maximum rack height	(mm)	1785
	Maximum rack width	(mm)	900
	Maximum rotation Ø	(mm)	1350
	Total acceptable payload	(kg)	200
<b>Space required to access building site</b>			
	Minimum door clearance	(mm)	1020

- Water drain, H=65 mm, Ø 3/4".
- ⚡ Electrical connection from the ceiling direct to the electrical power supply panel at base of oven.
- ▽ Water connection from the ceiling + stop valve. Ø 3/8"-12/14 mm, pressure : 2.5-4 bars
- ⊙ Steam exhaust duct Ø 150 mm. Draught between 0.1-0.4 mbars. Oven with steam exhaust hood: steam duct Ø 200 mm. Extraction between 800-1100 m<sup>3</sup>/h or 28252-38847 ft<sup>3</sup>/h.

● ● ● **Important note :**  
Required technical access above oven: 600 mm

# 10.83 MG



## Rotating rack oven - Fuel-oil / Gas

### Performances

- Rack oven for 800 x 1000 mm or 780 x 980 mm tray size or 2 trays 460 x 760 mm per level
- 180 to 216 baguettes of 250 g on 18 levels
- 108 to 135 loaves of 400 g on 15 levels

### Accessories

- Rack features: see rack data sheet
- Baking tray features: see baking tray data sheet

### The advantages

- Oven particularly designed for industrial use
- Large rack payload
- Very high capacity
- Very good energy yield
- High inertia owing to the mass of the lateral heat exchanger
- Oversized front features, door and hinges
- Slow ventilation avoiding drying of products
- Technical accessibility by the front of the oven

### Use

10.83 MG is an industrial fuel-oil or gas-heated rotating rack oven for bakers, pastry chefs and caterers. Multipurpose and productive, it is designed for large bakeries and industrialists.

### Operating principle

The rack, carried by the turntable, is crossed by a flow of hot air. The balanced ventilation speed, mass and radiation ensure optimal baking. Specific Bongard steam generators produce high quality steam, in sufficient quantity for the whole height of the rack. A gentle ventilation distributes an even heat without drying the product. The massive heat exchanger allows successive baking batches while maintaining an even bake and high productivity.

### Construction

- **Front**
  - polished stainless steel
  - tool holder
  - blade holder
  - control protection bumper
  - circuit breaker
- **Baking chamber**
  - Stainless steel
  - adjustable blowing slit
  - halogen lighting
  - driven by gear motor with torque reducer
- **Heat exchanger**
  - high performance refractory stainless steel heat exchanger
- **Access ramp**
  - retractable access ramp for a perfect and durable door tightness
- **Door**
  - 150 mm with double anchoring
  - door seals on 4 sides
  - over-dimensioned hinges
  - removable ventilated double-glazing
  - ergonomic handle
- **Steam generator**
  - steam generator composed of structured gutters in cast-iron
  - multi-level injection pipe
- **Steam vent**
  - 2 electric steam dampers
  - programmable steam evacuation
- **Insulation**
  - Performant insulation by crossed rock wool panel

## Rotating rack oven **10.83 MG**

<b>Model</b>	<b>France</b>	<b>Export</b>
<b>Drive system</b>		
Turntable	■	■
<b>Burner</b>		
Gas burner	■	■
Fuel-oil burner	□	□
Access burner to the front	■	■
<b>Door handle and control panel</b>		
Left	■	■
<b>Controls</b>		
Electronic controls Opticom	■	■
Electromechanical controls with deferred start-up timer	€	€
<b>Hood - Exhaust fan</b>		
Hood	■	■
Exhaust fan	€	€
<b>Additional options</b>		
Pulsed steam injection	■	■
Brass water solenoid valve	❖	■
Water filter to prevent scale deposits	€	€
Fresh air inlet on burner	■	■
Pressure reducing valve kit	■	■
<b>Electrical supply</b>		
3N~400V	■	■

<b>Power features</b>		
<b>Electric power</b>		
Total connecting power	(A)	16
Exhaust fan connecting power	(kW)	0,18
Heating power	(kW)	110
Average gradient of temperature rise	°C/min	10-12
Maximum baking temperature of the oven	°C	280

# Rotating rack oven 10.83 MG

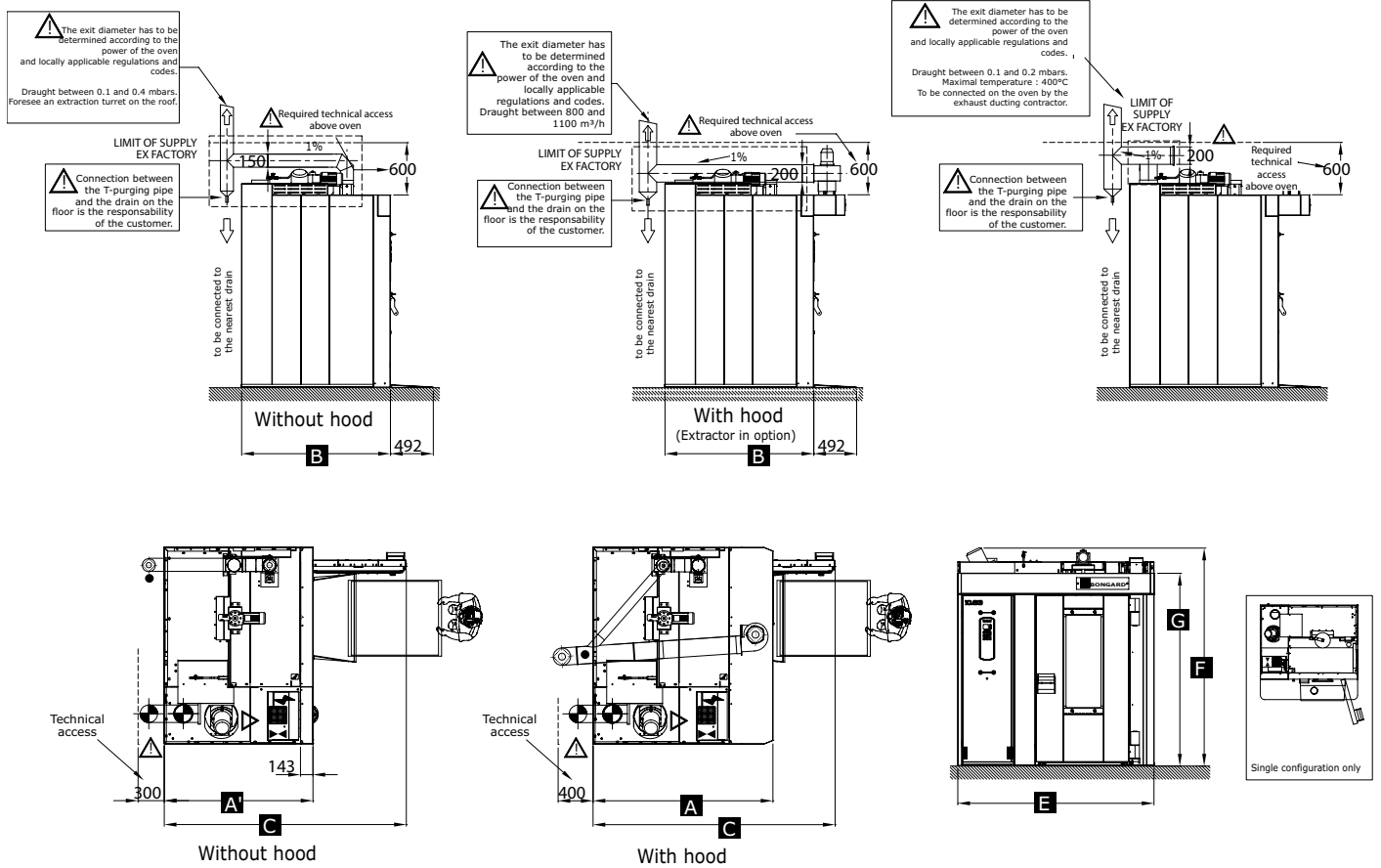

## Dimensional features

### Oven dimensions

<b>A</b>	Depth with hood	(mm)	2062
<b>A'</b>	Depth with headband	(mm)	1705
<b>B</b>	Depth on the floor	(mm)	1705
<b>C</b>	Depth (door opened)	(mm)	2774
<b>E</b>	Width on the floor	(mm)	2251
<b>F</b>	Total height, overall	(mm)	2492
<b>G</b>	Total height, oven front	(mm)	2200
	Floor area	(m <sup>2</sup> )	3,9
	Total weight	(kg)	1830

### Baking chamber

	Maximum rack height	(mm)	1785
	Maximum rack width	(mm)	900
	Maximum rotation Ø	(mm)	1350
	Total acceptable payload	(kg)	200

### Space required to access building site

	Minimum door clearance	(mm)	1020
--	------------------------	------	------

- Water drain, H=65 mm, Ø 3/4".
- ⚡ Electrical connection from the ceiling direct to the electrical power supply panel at base of oven.
- ⚙ Gas connection 3/4" or fuel connection 10/12 for the burner with cut off valve.
- ▽ Water connection from the ceiling + stop valve. Ø 3/8"-12/14 mm, pressure : 2.5-4 bars
- ⊙ Steam exhaust duct Ø 150 mm. Draught between 0.1-0.4 mbars. Oven with steam exhaust hood: steam duct Ø 200 mm. Extraction between 800-1100 m<sup>3</sup>/h or 28252-38847 ft<sup>3</sup>/h.
- ⊙ Steam exhaust, Ø 200 mm. Draught between 0.1-0.2 mbars.
- Fresh air inlet for the burner stainless steel 200 x 200 mm.

## ● ● ● Important note:

Required technical access above oven: 600 mm

# 8.64 E



## Rotating rack oven - Electric

### Performances

- Rack oven for 600 x 800 mm tray size
- 152 baguettes of 250 g on 19 levels
- 570 buns of 50 g on 19 levels
- Maximum capacity : 300 kg

### Accessories

- Rack features: see rack data sheet
- Baking tray features: see baking tray data sheet

### The advantages

- Fitted with «soft pulse» technology for gentle and effective ventilation
- Ideal for baking bread and pastry products
- Enhanced productivity
- Increased baking capacity for limited floor space
- Unrivalled ergonomics and hygiene
- New stainless steel and glass design
- Safety audited by an independent organization: APAVE

### Use

8.64 E is an electric rotating rack oven for bakers, pastry chefs and caterers. Multipurpose and highly compact.

### Operating principle

The latest Bongard technological breakthrough, the 8.64 was designed with state-of-the-art product development software. The "soft flow" technology and the possibility to reinforce steam production offer all the features needed for modern baking in bakeries, pastry shops and catering operations. The 8.64 oven guarantees a high quality of baking for a large range of products.

### Construction

- **Front**
  - polished stainless steel
  - tool holder
  - blade holder
  - control panel protection bumper
  - circuit breaker
- **Baking chamber**
  - Stainless steel
  - baking floor with 45° angle rims
  - adjustable air flow louvers
  - air flow managed by "soft flow" technology
  - halogen lighting
  - driven by gear motor with torque reducer
- **Heating element**
  - high performance S/S electric heating elements
- **Access ramp**
  - retractable access ramp for a perfect and durable door tightness
- **Door**
  - 150 mm depth with double anchoring
  - door seals on 4 sides
  - over-dimensioned hinges
  - removable ventilated double-glazing for an easy cleaning
  - ergonomic handle on door width in order to avoid any impact on the oven front
- **Steam generator**
  - steam generator composed of structured gutters in cast-iron
  - "ESG" modules in structured micro-wrought iron (optional)
  - multi-level injection pipe
- **Steam vent**
  - 2 electric steam dampers
  - programmable steam evacuation
- **Insulation**
  - Performant insulation by crossed rock wool panel



## Rotating rack oven **8.64 E**

<i>Model</i>	<i>France</i>	<i>Export</i>
<b>Drive system</b>		
Mechanical rack lifting system	■	■
Turntable	□	□
<b>Door handle and control panel</b>		
Left	■	■
Right	□	□
<b>Controls</b>		
Electronic controls Opticom	■	■
Computerized controls Intuitiv	€	€
Electromechanical Ergocom	□	□
<b>Headband - Hood - Exhaust fan</b>		
Headband	■	■
Hood with exhaust fan	€	€
<b>Additional options</b>		
Steam pulsed injection	■	■
Reinforced steam generator	€	€
Double reinforced steam generator	€	€
Brass water solenoid valve	■	■
Water filter to prevent scale deposits	€	€
Pressure reducing valve kit	■	■
Base 12 mm	€	€
Stainless steel exterior panels	€	€
<b>Electrical supply</b>		
3N~400V	■	■

<b>Power features</b>		
<b>Electric power</b>		
Total connecting power	(A)	100
Exhaust fan connecting power	(kW)	0,18
Heating power	(kW)	57
Average gradient of temperature rise	°C/min	8-10
Maximum baking temperature of the oven	°C	280

# Four à chariot rotatif 8.64 E

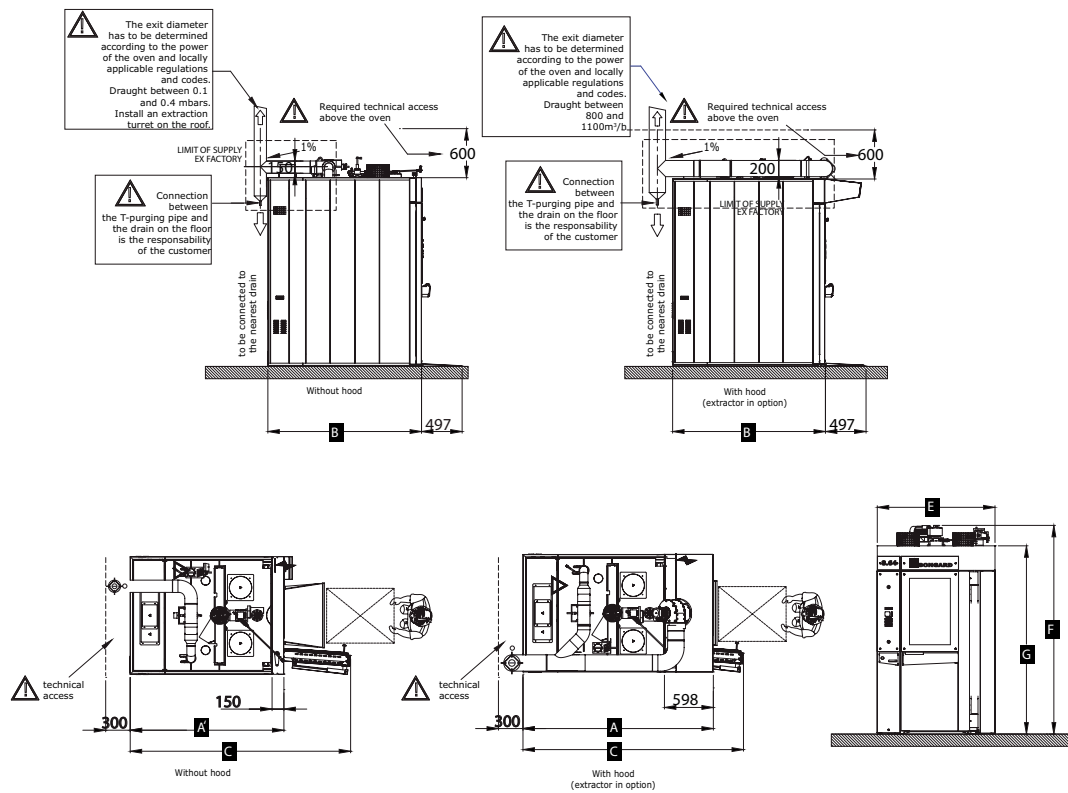

Dimensional features			
<b>Oven dimensions</b>			
<b>A</b>	Depth with hood	(mm)	2330
<b>A'</b>	Depth with headband	(mm)	1880
<b>B</b>	Depth on the floor	(mm)	1880
<b>C</b>	Depth (door opened)	(mm)	2700
<b>E</b>	Width on the floor	(mm)	1440
<b>F</b>	Total height, overall	(mm)	2600
<b>G</b>	Total height, oven front	(mm)	2300
	Floor area	(m <sup>2</sup> )	2,71
	Total weight	(kg)	1270
<b>Baking chamber</b>			
	Maximum rack height	(mm)	1900
	Maximum rack width	(mm)	680
	Maximum rotation Ø	(mm)	1120
	Total acceptable payload	(kg)	300
<b>Space required to access building site</b>			
	Minimum door clearance	(mm)	830

- Water drain, H=65 mm, Ø 3/4".
- ⚡ Electrical connection from the ceiling direct to the electrical power supply panel at base of oven.
- ▽ Water connection from the ceiling + stop valve. Ø 3/8"-12/14 mm, pressure : 1.5-2 bars
- ⊙ Steam exhaust duct Ø 150 mm. Draught between 0.1-0.4 mbars. Oven with steam exhaust hood: steam duct Ø 200 mm. Extraction between 800-950 m<sup>3</sup>/h or 28252-33550 ft<sup>3</sup>/h.

**■ Important note:**

Required technical access above oven: 600 mm

# 8.64 MG



## Rotating rack oven - Fuel-oil / Gas

### Performances

- Rack oven for 600 x 800 mm tray size
- 152 baguettes of 250 g on 19 levels
- 570 buns of 50 g on 19 levels
- Maximum capacity : 300 kg

### Accessories

- Rack features: see rack data sheet
- Baking tray features: see baking tray data sheet

### The advantages

- Fitted with «soft flow» technology for gentle and effective ventilation
- Ideal for baking bread and pastry products
- New heat exchanger for improved profitability
- Enhanced productivity
- Increased baking capacity for limited floor space
- Unrivalled ergonomics and hygiene
- New stainless steel and glass design
- CERTIGAZ certification
- Safety audited by an independent organization: APAVE

### Use

8.64 MG is a fuel-oil/gas rotating rack oven for bakers, pastry chefs and caterers. Multi-purpose and highly compact.

### Operating principle

The latest Bongard technological breakthrough, the 8.64 was designed with state-of-the-art product development software.

The "soft flow" technology and the possibility to reinforce steam production offer all the features needed for modern baking in bakeries, pastry shops and catering operations. The 8.64 oven guarantees a high quality of baking for a large range of products.

### Construction

#### • **Front**

- polished stainless steel
- tool holder
- blade holder
- control panel protection bumper
- circuit breaker

#### • **Baking chamber**

- Stainless steel
- baking floor with 45° angle rims
- adjustable air flow louvers
- air flow managed by "soft flow" technology
- halogen lighting
- driven by gear motor with torque reducer

#### • **Heating element**

- high performance refractory stainless steel heat exchanger

#### • **Access ramp**

- retractable access ramp for a perfect and durable door tightness

#### • **Door**

- 150 mm depth with double anchoring
- door seals on 4 sides
- over-dimensioned hinges
- removable ventilated double-glazing for an easy cleaning
- ergonomic handle on door width in order to avoid any impact on the oven front

#### • **Steam generator**

- steam generator composed of structured gutters in cast-iron
- "ESG" modules in structured micro-wrought iron (optional)
- multi-level injection pipe

#### • **Steam vent**

- 2 electric steam dampers
- programmable steam evacuation

#### • **Insulation**

- Performant insulation by crossed rock wool panel

## Rotating rack oven **8.64 MG**

<b>Model</b>	<b>France</b>	<b>Export</b>
<b>Drive system</b>		
Mechanical rack lifting system	■	■
Turntable	□	□
<b>Burner</b>		
Gas burner	■	■
fuel-oil burner	□	□
Access burner on the left	■	■
Access burner on the right	□	□
<b>Door handle and control panel</b>		
Left	■	■
Right	□	□
<b>Controls</b>		
Electronic controls Opticom	■	■
Computerized controls Intuitiv	€	€
Electromechanical controls Ergocom	□	□
<b>Headband - Hood - Exhaust fan</b>		
Headband	■	■
Hood with exhaust fan	€	€
<b>Additional options</b>		
Pulsed steam injection	■	■
Reinforced steam generator	€	€
Double reinforced steam generator	€	€
Brass water solenoid valve	■	■
Water filter to prevent scale deposits	€	€
Fresh air inlet on burner	■	■
Pressure reducing valve kit	■	■
Stainless steel exterior panels	€	€
Base 12 mm	€	€
<b>Electrical supply</b>		
3N~400V	■	■

<b>Power characteristics</b>		
Electric power		
Total connecting power	(A)	16
Exhaust fan connecting power	(kW)	0,18
Heating power	(kW)	70
Average gradient of temperature rise	°C/min	8-10
Maximum baking temperature of the oven	°C	280

# Rotating rack oven 8.64 MG

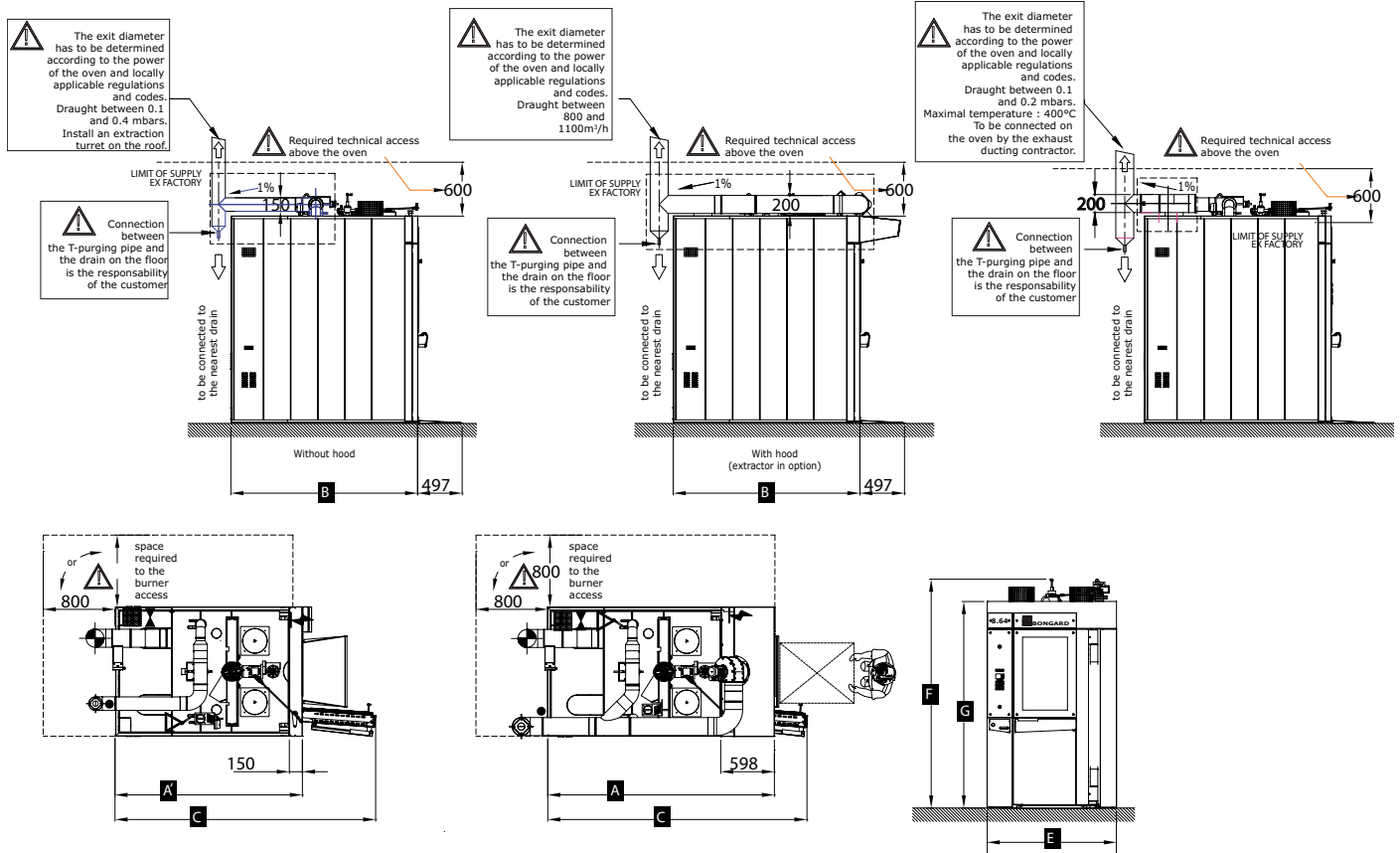

Dimensional features			
Oven dimensions			
A	Depth with hood	(mm)	2530
A'	Depth with headband	(mm)	2080
B	Depth on the floor	(mm)	2080
C	Depth (door opened)	(mm)	2900
E	Width on the floor	(mm)	1440
F	Total height, overall	(mm)	2600
G	Total height, oven front	(mm)	2300
	Floor area	(m <sup>2</sup> )	2,99
	Total weight	(kg)	1390
Baking chamber			
	Maximum rack height	(mm)	1900
	Maximum rack width	(mm)	680
	Maximum rotation Ø	(mm)	1120
	Total acceptable payload	(kg)	300
Space required to access building site			
	Minimum door clearance	(mm)	830

- Water drain, H=65 mm, Ø 3/4".
- ⚡ Electrical connection from the ceiling direct to the electrical power supply panel at base of oven.
- ⌘ Gas connection 3/4" or fuel connection 10/12 for the burner with cut off valve.
- ▽ Water connection from the ceiling + stop valve. Ø 3/8"-12/14 mm, pressure : 1.5-2 bars
- ⊙ Steam exhaust duct Ø 150 mm. Draught between 0.1-0.4 mbars. Oven with steam exhaust hood: steam duct Ø 200 mm. Extraction between 800-950 m<sup>3</sup>/h or 28252-33550 ft<sup>3</sup>/h.
- ⊙ Steam exhaust, Ø 200 mm. Draught between 0.1-0.2 mbars.
- Fresh air inlet for the burner stainless steel 200 x 200 mm.

### ● ● ● Important notes:

Required technical access above oven: 600 mm

Required technical access (electric battery or burner): 800 mm

# 8.84 E



## Rotating rack oven - Electric

### Performances

- Rack oven for 800 x 800 mm, 700x900 mm, 1000x600 or 2x 460x660 tray size
- 180 baguettes of 250 g on 18 levels
- 190 baguettes of 250 g on 19 levels

### Accessories

- Rack features: see rack data sheet
- Baking tray

### The advantages

- Fitted with «soft flow» technology for gentle and effective ventilation
- Ideal for baking bread and pastry products
- Enhanced productivity
- Increased baking capacity for limited floor space
- Unrivalled ergonomics and hygiene
- New stainless steel and glass design
- Safety audited by an independent organisation: APAVE

### Use

8.84 E is an electric rotating rack oven for bakers, pastry chefs and caterers.

### Operating principle

The latest Bongard technological breakthrough, the 8.84 was designed with state-of-the-art product development software.

The "soft flow" technology and the possibility to reinforce steam production offer all the features needed for modern baking in bakeries, pastry shops and catering operations. The 8.84 oven guarantees a high quality of baking for a large range of products.

### Construction

#### • **Front -polished stainless steel**

- tool holder
- blade holder
- control panel protection bumper
- circuit breaker

#### • **Baking chamber**

- Stainless steel
- baking floor with 45° angle rims
- adjustable air flow louvers
- air flow managed by "soft flow" technology
- halogen lighting
- driven by gear motor with torque reducer

#### • **Heating element**

- high performance S/S electric heating elements

#### • **Access ramp**

- retractable access ramp for a perfect and durable door tightness

#### • **Door**

- 150 mm depth with double anchoring
- door seals on 4 sides
- over-dimensioned hinges
- removable ventilated double-glazing for an easy cleaning
- ergonomic handle on door width in order to avoid any impact on the oven front

#### • **Steam generator**

- steam generator composed of structured gutters in cast-iron
- ESG modules in structured micro-wrought iron (optional)
- multi-level injection pipe

#### • **Steam vent**

- 2 electric steam dampers
- programmable steam evacuation

#### • **Insulation**

- Performant insulation by crossed rock wool panel

## Rotating rack oven **8.84 E**



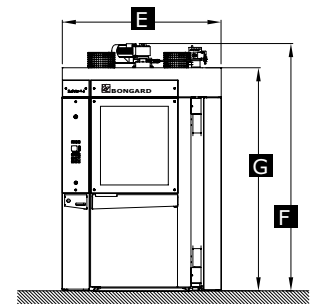
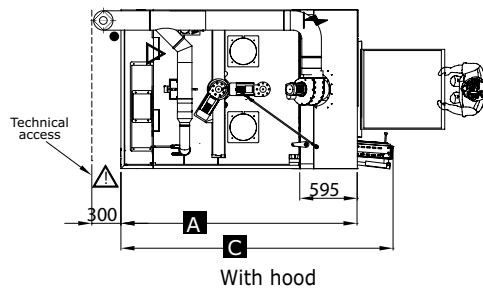
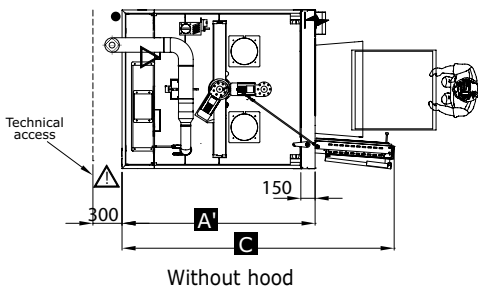
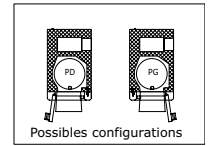
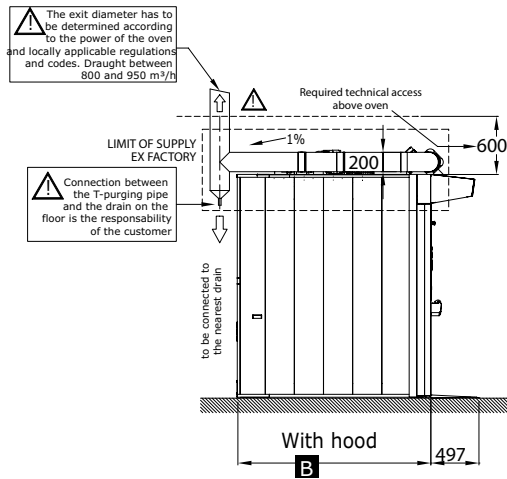
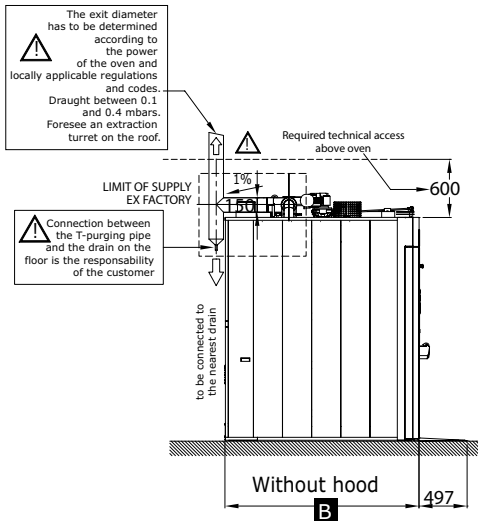

<b>Model</b>	<b>France</b>	<b>Export</b>
<b>Drive system</b>		
Mechanical rack lifting system	■	■
Turntable	□	□
<b>Door handle and control panel</b>		
Left	■	■
Right	□	□
<b>Controls</b>		
Electronic controls Opticom	■	■
Computerized controls Intuitiv	€	€
Electromechanical controls Ergocom	□	□
<b>Headband - Hood - Exhaust fan</b>		
Headband	■	■
Hood with exhaust fan	€	€
<b>Additional options</b>		
Pulsed steam injection	■	■
Reinforced steam generator	❖	❖
Double reinforced steam generator	❖	❖
Brass water solenoid valve	■	■
Water filter to prevent scale deposits	€	€
Pressure reducing valve kit	■	■
Base 12 mm	€	€
Stainless steel exterior panels	€	€
<b>Electrical supply</b>		
3N~400V	■	■

<b>Power features</b>		
<b>Electric power</b>		
Total connecting power	(A)	125
Exhaust fan connecting power	(kW)	0,18
Heating power	(kW)	69
Average gradient of temperature rise	°C/min	8-10
Maximum baking temperature of the oven	°C	280

# Rotating rack oven 8.84 E



Dimensional features			
<b>Oven dimensions</b>			
<b>A</b>	Depth with hood	(mm)	2520
<b>A'</b>	Depth with headband	(mm)	2080
<b>B</b>	Depth on the floor	(mm)	2080
<b>C</b>	Depth (door opened)	(mm)	3100
<b>E</b>	Width on the floor	(mm)	1640
<b>F</b>	Total height, overall	(mm)	2600
<b>G</b>	Total height, oven front	(mm)	2300
	Floor area	(m²)	3,41
	Total weight	(kg)	1550
<b>Baking chamber</b>			
	Maximum rack height	(mm)	1900
	Maximum rack width	(mm)	880
	Maximum rotation Ø	(mm)	1320
	Total acceptable payload	(kg)	350
<b>Space required to access building site</b>			
	Minimum door clearance	(mm)	930

-  Water drain, H=65 mm, Ø 3/4".
-  Electrical connection from the ceiling direct to the electrical power supply panel at base of oven.
-  Water connection from the ceiling + stop valve. Ø 3/8"-12/14 mm, pressure : 1.5-2 bars
-  Steam exhaust duct Ø 150 mm. Draught between 0.1-0.4 mbars. Oven with steam exhaust hood: steam duct Ø 200 mm. Extraction between 800-950 m³/h or 28252-33550 ft³/h.

• • • **Important note:**

Required technical access (electric battery or heat exchanger): 600 mm



# 8.84 MG



## Rotating rack oven - Fuel-oil / Gas

### Performances

- Rack oven for 800 x 800 mm, 700x900 mm, 1000x600 or 2x 460x660 tray size
- 180 baguettes of 250 g on 18 levels
- 190 baguettes of 250 g on 19 levels

### Accessories

- Rack features: see rack data sheet
- Baking tray features: see baking tray data sheet

### The advantages

- Fitted with «soft flow» technology for gentle and effective ventilation
- Ideal for baking bread and pastry products
- New heat exchanger for improved profitability
- Enhanced productivity
- Increased baking capacity for limited floor space
- Unrivalled ergonomics and hygiene
- New stainless steel and glass design
- CERTIGAZ certification
- Safety audited by an independent organisation: APAVE

### Use

8.84 MG is a fuel-oil/gas rotaring rack oven for bakers, pastry chefs and caterers.

### Operating principle

The latest Bongard technological breakthrough, the 8.84 was designed with state-of-the-art product development software.

The "soft flow" technology and the possibility to reinforce steam production offer all the features needed for modern baking in bakeries, pastry shops and catering operations. The 8.84 oven guaranties a high quality of baking for a large range of products.

### Construction

- **Front**
  - polished stainless steel
  - tool holder
  - blade holder
  - control panel protection bumper
  - circuit breaker
- **Baking chamber**
  - Stainless steel
  - baking floor with 45° angle rims
  - adjustable air flow louvers
  - air flow managed by « soft flow » technology
  - halogen lighting
  - driven by gear motor with torque reducer
- **Heating element**
  - high performance refractory stainless steel heat exchanger
- **Access ramp**
  - retractable access ramp for a perfect and durable door tightness
- **Door**
  - 150 mm depth with double anchoring
  - door seals on 4 sides
  - over-dimensioned hinges
  - removable ventilated double-glazing for an easy cleaning
  - ergonomic handle on door width in order to avoid any impact on the oven front
- **Steam generator**
  - steam generator composed of structured gutters in cast-iron
  - ESG modules in structured micro-wrought iron (optional)
  - multi-level injection pipe
- **Steam vent**
  - 2 electric steam dampers
  - programmable steam evacuation
- **Insulation**
  - Performant insulation by crossed rock wool panel

## Rotating rack oven **8.84 MG**

<b>Model</b>	<b>France</b>	<b>Export</b>
<b>Drive system</b>		
Mechanical rack lifting system	■	■
Turntable	□	□
<b>Burner</b>		
Gas burner	■	■
Fuel-oil burner	□	□
Access burner on the left	■	■
Access burner on the right	□	□
<b>Door handle and control panel</b>		
Left	■	■
Right	□	□
<b>Controls</b>		
Electronic controls Opticom	■	■
Computerized controls Intuitiv	€	€
Electromechanical controls Ergocom	□	□
<b>Headband - Hood - Exhaust fan</b>		
Headband	■	■
Hood with exhaust fan	€	€
<b>Additional options</b>		
Pulsed steam injection	■	■
Reinforced steam generator	€	€
Double reinforced steam generator	€	€
Heat exchanger	■	■
Brass water solenoid valve	■	■
Water filter to prevent scale deposits	€	€
Fresh air inlet on burner	■	■
Pressure reducing valve kit	■	■
Stainless steel exterior panels	€	€
Base 12 mm	€	€
<b>Electrical supply</b>		
3N~400V	■	■

<b>Power features</b>		
Electric power		
Total connecting power	(A)	16
Exhaust fan connecting power	(kW)	0,18
Heating power	(kW)	100
Average gradient of temperature rise	°C/min	8-10
Maximum baking temperature of the oven	°C	280

# Rotating rack oven 8.84 MG

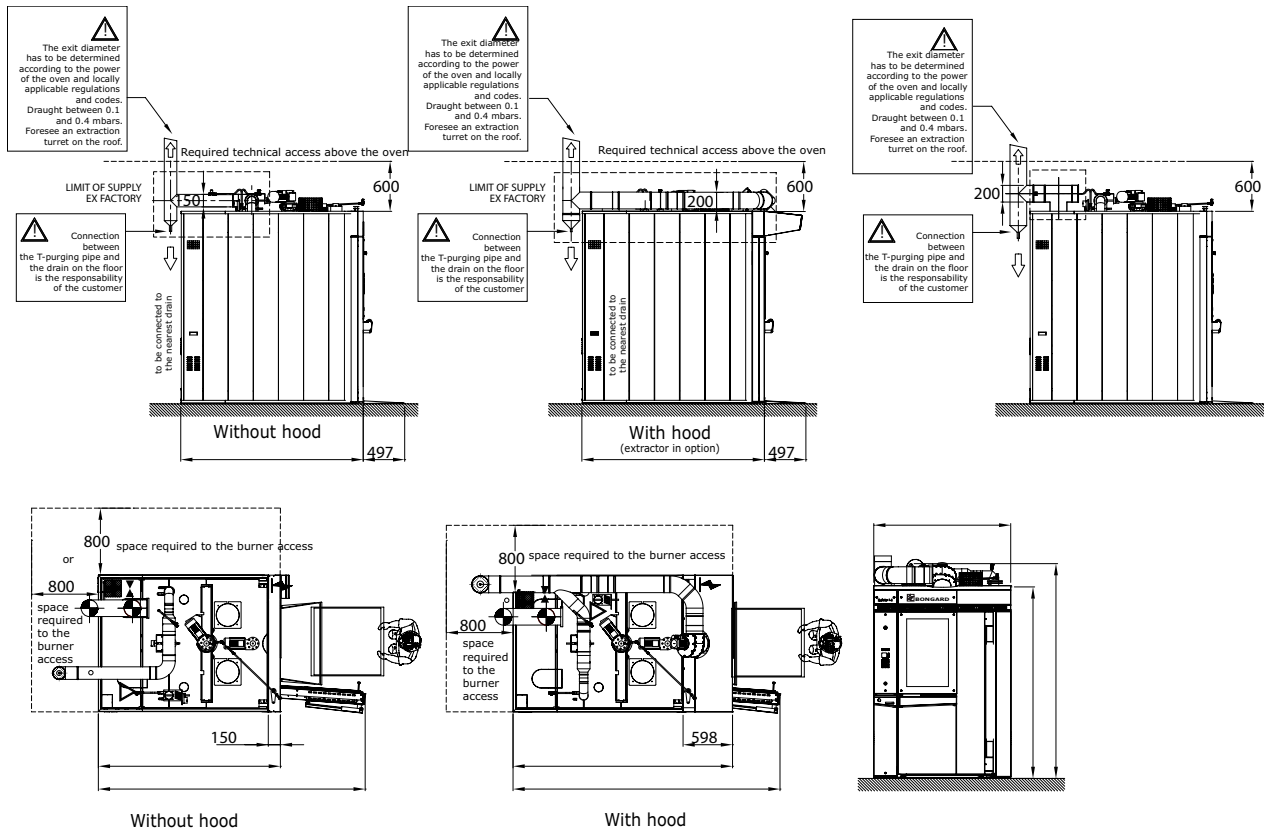

Dimensional features			
<b>Oven dimensions</b>			
<b>A</b>	Depth with hood	(mm)	2730
<b>A'</b>	Depth with headband	(mm)	2280
<b>B</b>	Depth on the floor	(mm)	2280
<b>C</b>	Depth (door opened)	(mm)	3300
<b>E</b>	Width on the floor	(mm)	1640
<b>F</b>	Total height, overall	(mm)	2600
<b>G</b>	Total height, oven front	(mm)	2300
	Floor area	(m <sup>2</sup> )	3,74
	Total weight	(kg)	1580
<b>Baking chamber</b>			
	Maximum rack height	(mm)	1900
	Maximum rack width	(mm)	880
	Maximum rotation Ø	(mm)	1320
	Total acceptable payload	(kg)	350
<b>Space required to access building site</b>			
	Minimum door clearance	(mm)	930

- Water drain, H=65 mm, Ø 3/4".
- ⚡ Electrical connection from the ceiling direct to the electrical power supply panel at base of oven.
- ▲ Gas connection 3/4" or fuel connection 10/12 for the burner with cut off valve.
- ▽ Water connection from the ceiling + stop valve. Ø 3/8"-12/14 mm, pressure : 1.5-2 bars
- ⊙ Steam exhaust duct Ø 150 mm. Draught between 0.1-0.4 mbars. Oven with steam exhaust hood: steam duct Ø 200 mm. Extraction between 800-950 m<sup>3</sup>/h or 28252-33550 ft<sup>3</sup>/h.
- ⊙ Steam exhaust, Ø 200 mm. Draught between 0.1-0.2 mbars.
- Fresh air inlet for the burner stainless steel 200 x 200 mm.

● ● ● **Important notes:**

Required technical access above oven: 600 mm  
 Required technical access (electric battery or burner): 800 mm

# 12.84 MG



## Rotating rack oven for 1 or 2 racks - Fuel-Oil/gas

### Performances

- 2 racks 600 x 800 mm
- 1 rack 1000 x 800 mm
- 304 baguettes of 250 g on 19 levels
- 1140 buns of 50 g on 19 levels

### Accessories

- Rack features: see rack data sheet
- Baking tray features: see baking tray data sheet

### The advantages

- Ground-level floor for easy insertion of the racks
- Progressive starting and stopping of rack rotation
- Electric rack lifting system
- «Soft flow» technology
- Rich and generous steam
- Intuitive control with water measuring device
- Low flue gases temperature
- Lateral exchanger accessible from the front of the oven
- May be built in on 3 sides
- CERTIGAZ certification
- Safety audited by an independent organisation: APAVE

### Use

12.84 MG is a fuel-oil/gas heated rotating rack oven for bakers, pastry chefs and caterers. It can be used with 1 or 2 racks. Multipurpose and productive, it is designed for large bakeries and industrialists.

### Operating principle

The 12.84 model, latest in the Series 4 range of rack ovens, offers high production capacity which can receive 2 racks simultaneously, for a maximum weight of 600Kg. This robustly built oven is specifically designed to last in demanding industrial conditions. Everything has been done to guarantee an exceptional baking result for a wide range of products. The ground-level floor, the progressive rack start and stop system and «soft flow» technology are all assets that allow high versatility, even baking and comfort of use.

### Construction

- **Front**
  - polished stainless steel
  - tools holder
  - blade holder
  - control protection bumper
  - glazing with reflective tempered glass
- **Baking chamber**
  - stainless steel
  - ground-level floor requiring no ramp
  - adjustable blowing slit
  - neon lighting
  - driven by gear motor with torque reducer
- **Heat exchanger**
  - high performance refractory stainless steel heat exchanger
- **Door**
  - 3 door seals on the baking chamber, 1 wiper seal under the door
  - special hinges system to avoid the wear of the door seal
- **Steam generator**
  - 4 ranges of gutters in structured micro-wrought iron
  - 2 additional columns ESG (possible option)
  - multi-level injection pipe
- **Steam vent**
  - 2 electric steam dampers
  - programmable steam evacuation
- **Isolation**
  - performant insulation by crossed rock wool panel

## Rotary rack oven **12.84 MG**

<b>Models</b>	<b>France</b>	<b>Export</b>
<b>Drive system</b>		
Rack lifting system	■	■
Turntable	□	□
<b>Burner</b>		
Gas burner	■	■
Fuel-oil burner	□	□
Access burner on the front	■	■
<b>Door handle and control panel</b>		
Left	■	■
<b>Controls</b>		
Computerized controls Intuitiv' operating a water meter	■	■
<b>Headband - Hood - Exhaust fan</b>		
Headband	■	■
Hood with exhaust fan	€	€
<b>Steam production</b>		
4 ranges of gutters	■	■
+ 2 steam generators (ESG)	€	€
Water meter	■	■
Pulsed steam injection	■	■
<b>Additional options</b>		
Brass water solenoid valve	■	■
Water filter to prevent scale deposits	€	€
Pressure reducing valve kit	■	■
Base and access ramp	€	€
Heat exchanger with reinforced bottom	■	■
Outer oven panels in stainless steel	€	€
<b>Tension d'alimentation</b>		
3N~400V	■	■

<b>Power features</b>		
<b>Electric power</b>		
Total connecting power	(A)	16
Exhaust fan connecting power	(kW)	0,18
Heating power	(kW)	150
Average gradient of temperature rise	°C/min	+ -13
Maximum baking temperature of the oven	°C	280

### ● ● ● **Important notes:**

- The installation requires a flat and levelled ground ( the maximum allowable slope is 0,3%)  
Otherwise it is recommended to install the oven on a base equipped with an access ramp.
- For even cooking and in order to ensure an even wear of the rotation mechanism, the load must be balanced between the two racks.
- In the case of an oven fitted with a turntable, the weight difference between the two racks 600 X 800 that are on the turntable plate cannot exceed 30kg  
If not the case, the rotation of the turntable is not working correctly.

# Rotary rack oven 12.84 MG

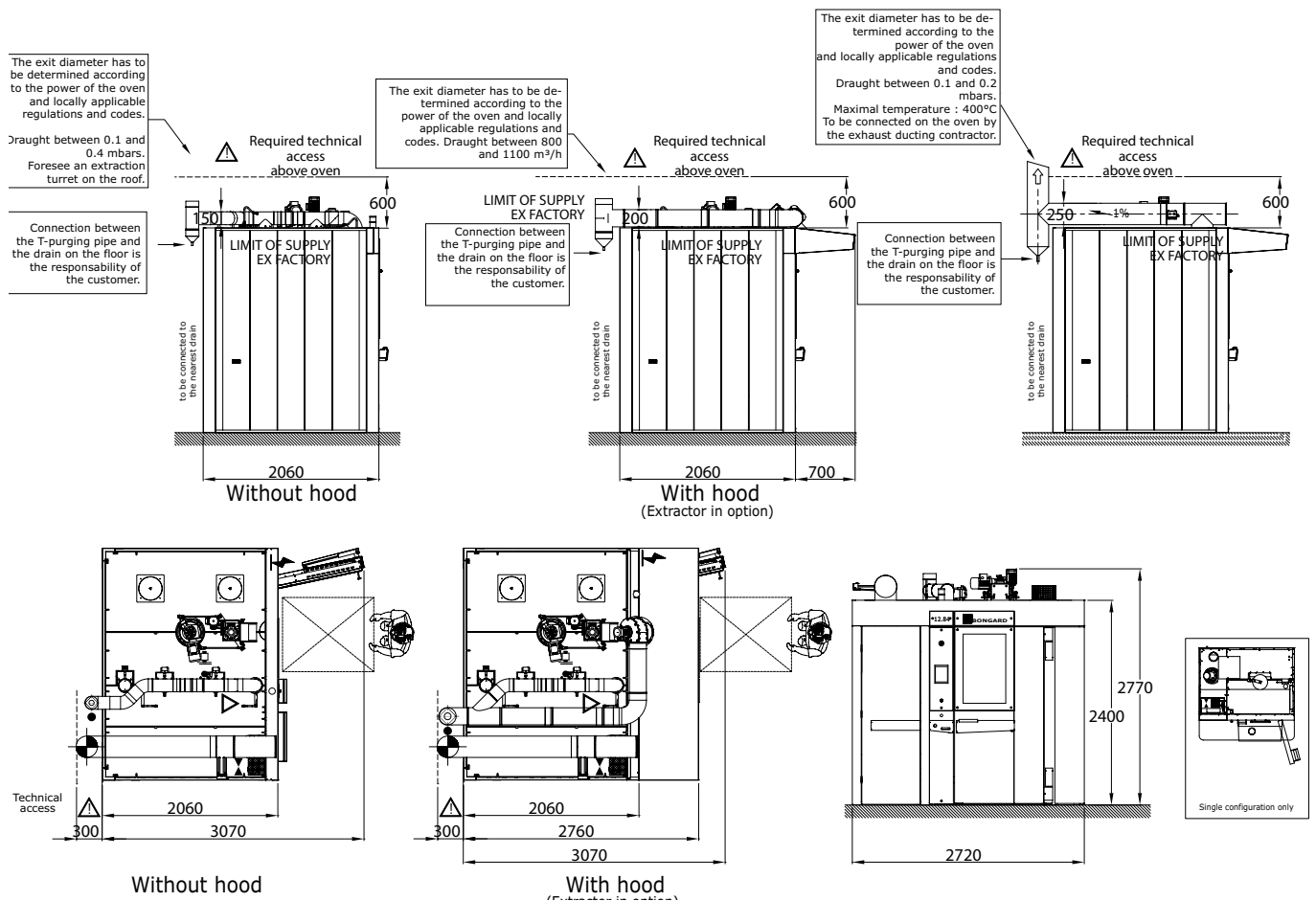

Dimensional features			
<b>Oven dimensions</b>			
<b>A</b>	Depth with hood	(mm)	2760
<b>A'</b>	Depth with headband	(mm)	2060
<b>B</b>	Depth on the floor	(mm)	2060
<b>C</b>	Depth (door opened)	(mm)	3070
<b>E</b>	width on the floor	(mm)	2720
<b>F</b>	Overall height	(mm)	2770
<b>G</b>	Total height, oven front	(mm)	2400
	Floor area	(m <sup>2</sup> )	5,6
	Total weight	(kg)	2500
<b>Baking chamber</b>			
	Maximum rack height	(mm)	1960
	Maximum rack width	(mm)	870
	Ø maximum rotation	(mm)	1630
	Total acceptable payload	(kg)	600
<b>Space required to access building site</b>			
	Minimum door clearance	(mm)	1200

● ● ● **Important note:**  
Requiral technical access above oven: 600 mm

# Accessories



## Rack ovens

### Performances

Number of levels : from 12 to 19 depends of the model

### Use

For rack ovens 400 x 800, 460 x 800, 600 x 800, 700 x 900, 800 x 800 and 800 x 1000 mm

### Construction

#### On all racks :

- Stainless steel rack
- 30 mm wide tray slides with rounded ends
- Galvanized fork (except Oscar : stainless steel fork)
- Wheels  $\varnothing$  80 mm (except Oscar :  $\varnothing$  100 mm) made of synthetic fibre fitted with struts & teflon washers
- Maintenance : replacement of struts & washers every 6 months, and lubricating the pivot once a year

#### Optional accessories

- Stainless steel castors
- Stainless steel forks fitted with teflon seal with greasing nipple on top & synthetic wheels fitted with a ball bearing
- Casters tested and approved by "LEMPA", in accordance with the European regulation EN 1673 on the rotating rack ovens.

#### • • • note :

The number of levels & the type of baking tray must take into account the normal development during proofing of the products, in order to ensure good air circulation around them during the baking process (drawing below).

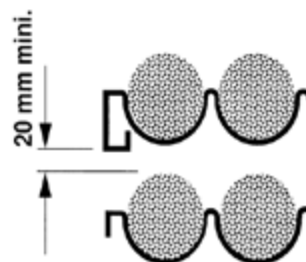

## Accessories for rack ovens - 6.43

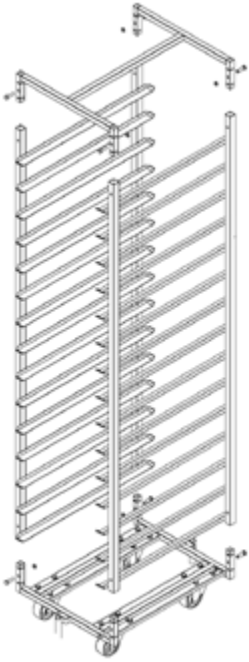

<b>Rack 400x600</b>				
<b>Nb of levels</b>	15	16	17	18
Spacing of (mm)	108	101	95	89

- Disassembled rack to assemble on site
- Suitable for TURNTABLE, guided by 2 pins on the bottom of the rack
- Vertical posts 25 x 25 mm
- Total rack height : 1775 mm

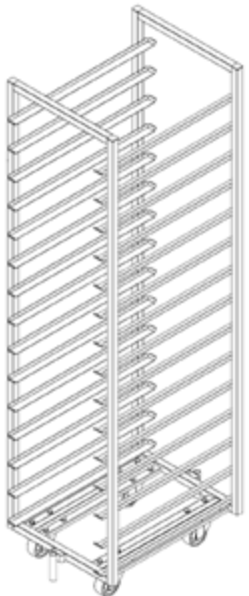

<b>Rack 400x600</b>				
<b>Nb of levels</b>	15	16	17	18
Spacing of (mm)	108	101	95	89

- One piece welded S/S racks, shipped ready to use
- Suitable for TURNTABLE, guided by 2 pins on the bottom of the rack
- Vertical posts 25 x 25 mm
- Total rack height : 1775 mm

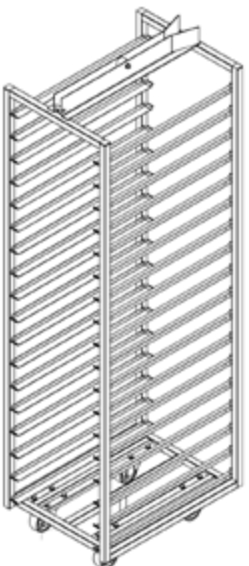

<b>Rack 400x600</b>				
<b>Nb of levels</b>	15	16	17	18
Spacing of (mm)	108	101	95	89

- One piece welded S/S racks, shipped ready to use
- Hook drive, guided by 2 indices at the top of the rack
- Vertical posts 25 x 25 mm
- Total height : 1807 mm



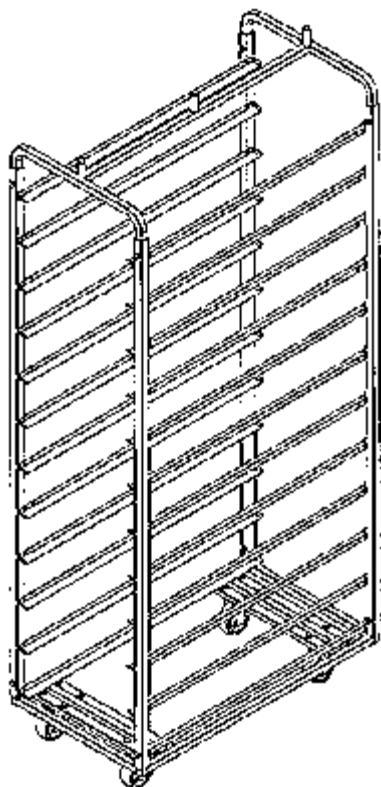

**Rack 400 x 800 - 460 x 800**

<b>Nb of levels</b>	12	15	16	18
Spacing of (mm)	135	108	101	90

- Disassembled rack to assemble on site
- Guided by 3 indices on the top of the rack
- Vertical posts 25 x 25 mm
- Total height : 1820 mm

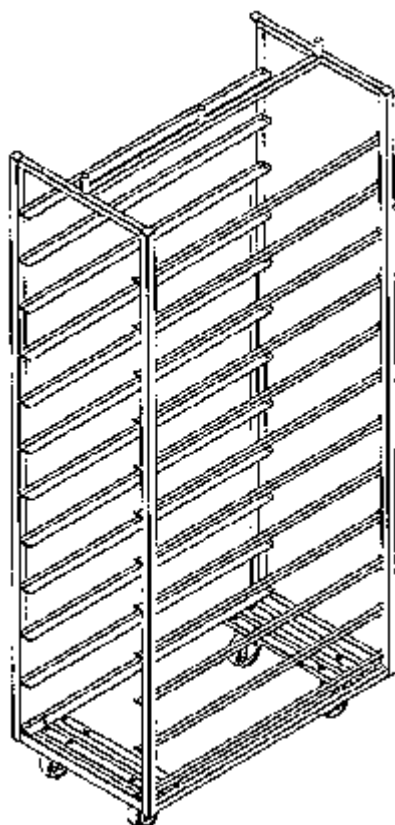

**Rack 400 x 800 - 460 x 800**

<b>Nb of levels</b>	12	15	16	18
Spacing of (mm)	135	108	101	90

- One piece welded S/S racks, shipped ready to use
- Guided by 3 indices on the top of the rack
- Vertical posts 25 x 25 mm
- Total height : 1820 mm

## Accessories for rack ovens - 8.43

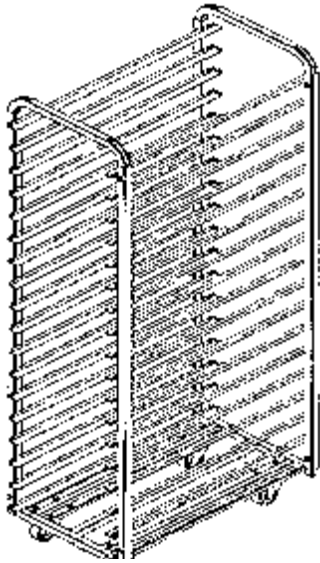

**Rack 400 x 800 - 460 x 800**

Nb of levels	12	15	16	18
Spacing of (mm)	135	108	101	90

- Disassembled rack to assemble on site
- Carrier drive, guided by 2 indices on the bottom of the rack
- Vertical posts 30 x 30 mm
- Total height : 1775 mm

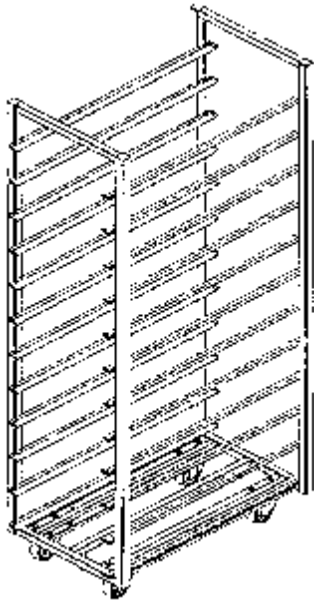

**Rack 400 x 800 - 460 x 800**

Nb of levels	12	15	16	18
Spacing of (mm)	135	108	101	90

- One piece welded S/S racks shipped ready to use
- Carrier drive, guided by 2 indices on the bottom of the rack
- Vertical posts 30 x 30 mm
- Total height : 1775 mm

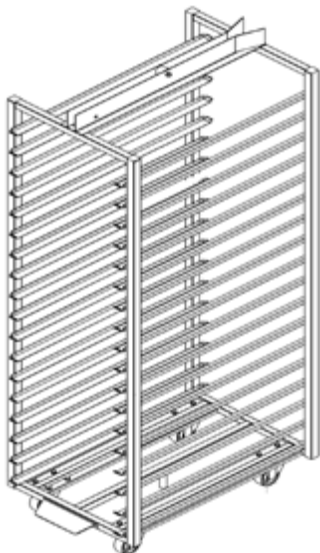

**Rack 400 x 800 - 460 x 800**

Nb of levels	12	15	16	18
Spacing of (mm)	131	104	97.5	86.5

- One piece welded S/S racks shipped ready to use
- Carrier drive, guided by 2 indices on the bottom of the rack
- Vertical posts 30 x 30 mm
- Total height : 1789 mm

## Accessories for **rack ovens - 10.83**

---

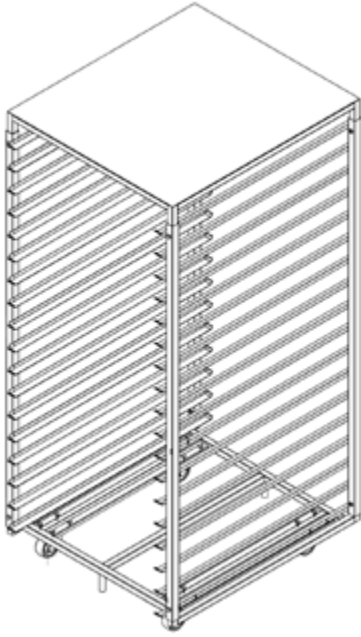

### **Rack 700 x 900 - 2x (460 x 660) - 800 x 800 - 1000 x 800**

<b>Nb of levels</b>	12	15	16	18
Spacing of (mm)	135	108	101	90

- Disassembled rack to assemble on site
- Carrier drive, guided by 2 indices on the bottom of the rack
- Vertical posts 30 x 30 mm
- Total height : 1777 mm

## Accessories for rack ovens - 8.64

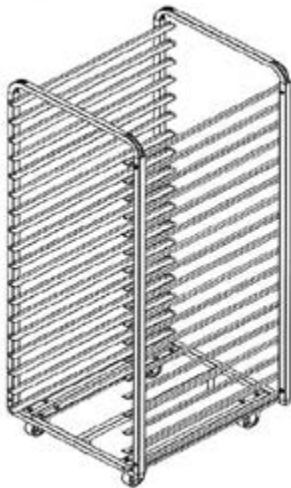

### Rack 600 x 800

Nb of levels	12	15	16	18	19
Spacing of (mm)	135	108	101	90	88

- Disassembled rack to assemble on site
- Carrier drive, guided by 2 indices on the bottom of the rack
- Vertical posts 30 x 30 mm
- Total height : 1775 mm until 18 levels  
1831 mm from 19 levels

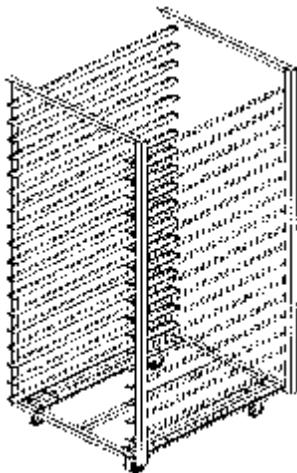

### Rack 600 x 800

Nb of levels	12	15	16	18	19
Spacing of (mm)	135	108	101	90	88

- Disassembled rack to assemble on site
- Carrier drive, guided by 2 indices on the bottom of the rack
- Vertical posts 30 x 30 mm
- Total height : 1775 mm until 18 levels  
1831 mm from 19 levels

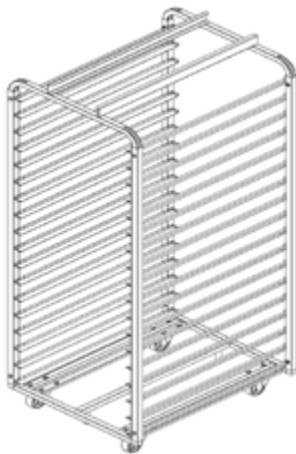

### Rack 600 x 800

Nb of levels	12	15	16	18	19
Spacing of (mm)	144	113	105.6	93	88

- Disassembled rack to assemble on site
- Drive with lifting mechanism, using rails above the rack
- Vertical posts 30 x 30 mm
- Total height : 1881 mm

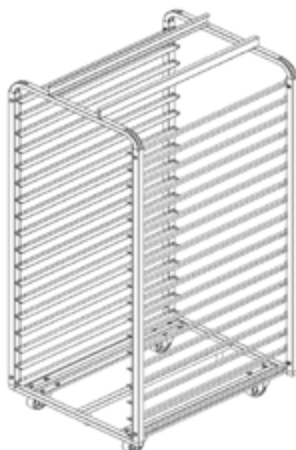

### Rack 600 x 800

Nb of levels	12	15	16	18	19
Spacing of (mm)	144	113	105.6	93	88

- One piece welded S/S racks shipped ready to use
- Drive with lifting mechanism, using rails above the rack
- Vertical posts 30 x 30 mm
- Total height : 1881 mm

## Accessories for rack ovens - 8.84

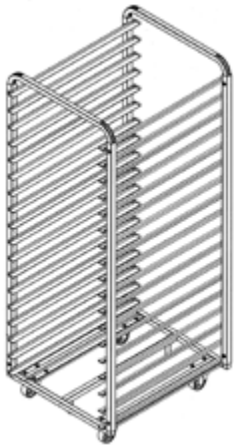

### **Rack 800 x 800 - 600 x 1000 - 700 x 900 - 2x (460 x 660)**

Nb of levels	12	15	16	18	19
Spacing of (mm)	144	113	105.6	93	88

- Disassembled rack to assemble on site
- Drive with lifting mechanism, using rails above the rack
- Vertical posts 30 x 30 mm
- Total height : 1831 mm

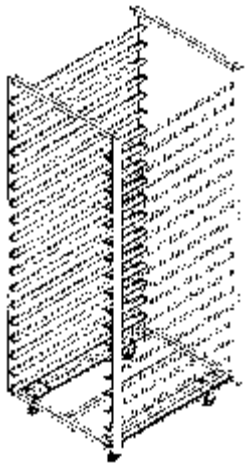

### **Rack 800 x 800 - 600 x 1000 - 700 x 900 - 2x (460 x 660)**

Nb of levels	12	15	16	18	19
Spacing of (mm)	144	113	105.6	93	88

- One piece welded S/S racks shipped ready to use
- Drive with lifting mechanism, using rails above the rack
- Vertical posts 30 x 30 mm
- Total height : 1831 mm

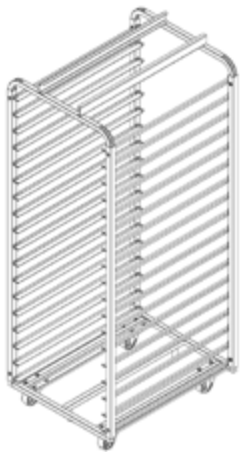

### **Rack 800 x 800 - 600 x 1000 - 700 x 900 - 2x (460 x 660) - 580 x 1000**

Nb of levels	12	15	16	18	19
Spacing of (mm)	144	113	105.6	93	88

- Disassembled rack to assemble on site
- Drive with lifting mechanism, using rails at the top of the rack
- Vertical posts 30 x 30 mm
- Total height : 1881 mm

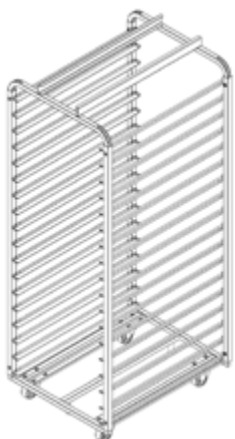

### **Rack 800 x 800 - 600 x 1000 - 700 x 900 - 2x (460 x 660) - 580 x 1000**

Nb of levels	12	15	16	18	19
Spacing of (mm)	144	113	105.6	93	88

- One piece welded S/S racks shipped ready to use
- Drive with lifting mechanism, using rails at the top of the rack
- Vertical posts 30 x 30 mm
- Total height : 1881 mm

## Accessories for rack ovens - 12.84

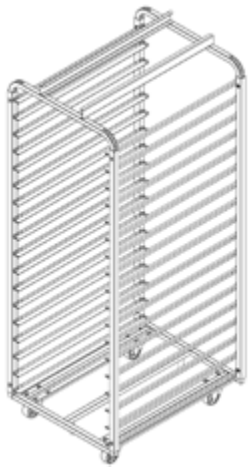

### Universal rack 600 x 800

Nb of levels	12	15	16	18	19
Spacing of (mm)	135	113	105.6	93	88

Suitable  
with 8.64

- Disassembled rack to assemble on site
- Can be delivered for 12.84 with turntable only
- Vertical posts 30 x 30 mm
- Total height : 1881 mm



### Universal rack 600 x 800

Nb of levels	12	15	16	18	19
Spacing of (mm)	135	113	105.6	93	88

Suitable  
with 8.64

- One piece welded S/S racks shipped ready to use
- Can be delivered for 12.84 with lifting system or turntable
- Vertical posts 30 x 30 mm
- Total height : 1881 mm



### Rack 800 x 1000

Nb of levels	12	15	16	18	19
Spacing of (mm)	135	113	105.6	93	88

No  
Suitable  
with 10.83

- Disassembled rack to assemble on site
- Can be delivered for 12.84 with turntable only
- Carrier drive, guided by 2 indices on the bottom of the rack
- Vertical posts 30 x 30 mm
- Total height : 1881 mm



### Rack 800 x 1000

Nb of levels	12	15	16	18	19
Spacing of (mm)	135	113	105.6	93	88

No  
Suitable  
with 10.83

- One piece welded S/S racks shipped ready to use
- Can be delivered for 12.84 with lifting system or turntable
- Vertical posts 30 x 30 mm
- Total height : 1881 mm

# Baking trays



Stainless steel Baking mesh



Oven supports



Baking mesh for pre-baked

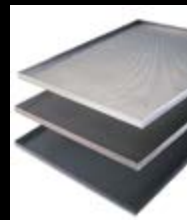

Baking tray 90° edges



Baking tray 45° edges

## Rack ovens



Stainless steel baking mesh detail



Silicon oven supports detail

### Use

Baking racks for baking racks aimed at 400 x 600, 400 x 800, 460 x 800, 600 x 800, 700 x 900, 800 x 800 et 800 x 1000 rotary ovens.

### Construction

#### • • • Mesh and oven supports

##### Stainless steel baking mesh

- Honeycombed stainless steel tray with anti-adherent silicone coating
- Frame in full stainless steel thread

##### Baking rack

- Aluminium perforated tray
- Stainless steel frame
- Available with anti-adhesive silicone or Teflon coating

##### Baking mesh for pre-baked

- 10x10m wide mesh stainless steel tray
- Without coating
- Not suitable for initial baking

#### • • • Baking tray

##### Baking tray, 45° edges

- Aluminium tray
- Edges: inner height: 10 mm
- Available in rough material or with silicone or Teflon coating
- Tray available in a non-perforated version or with 3 mm or 6 mm perforations to favour air passage



Perforation Ø 3mm



Perforation Ø 6mm

##### Baking tray, 90° edges

- Aluminium tray
- Edges: inner height: 10 mm
- Welded and reinforced edges, inner height: 25 mm (20 mm for the 400 x 600 version)
- Available in rough material or with silicone or Teflon coating
- Tray available in a non-perforated version or with 3 mm or 6 mm perforations to favour air passage

## Oven supports for **rotary rack oven 6.43**

Type of products	<b>Baguettes 250 g</b>			
Number of levels/rack	18	17	16	15
Type of trays	Mesh 6 AL 600			
Overall dimensions (mm)	400 x 600			
Capacities (indicative values)				
Pieces per mesh	6	6	6	6
Pieces per rack	108	102	96	90

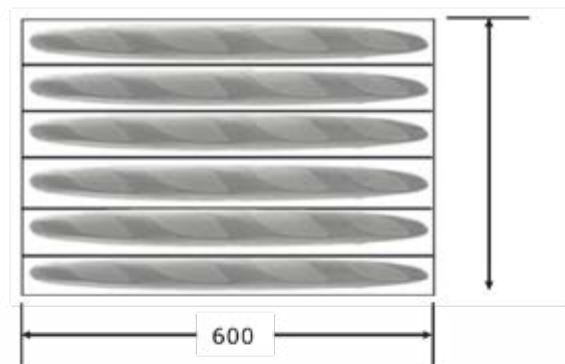

Type of products	<b>Baguettes 250 g</b>			
Number of levels/rack	18	17	16	15
Type of trays	Mesh 5 AL 600			
Overall dimensions (mm)	400 x 600			
Capacities (indicative values)				
Pieces per mesh	5	5	5	5
Pieces per rack	90	85	80	75

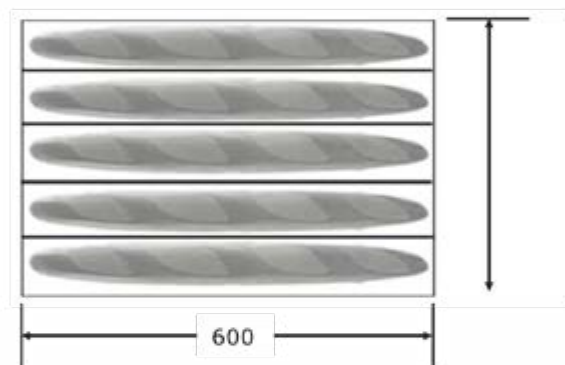

Type of products	<b>Pastry, Danish</b>			
Number of levels/rack	18	17	16	15
Type of trays	Baking tray			
Spacing between trays (mm)	89	95	101	108
Capacities (indicative values)				
Pieces per mesh	15 - 20	15 - 20	15 - 20	15 - 20
Pieces per rack	270 - 360	255 - 340	240 - 320	225 - 300

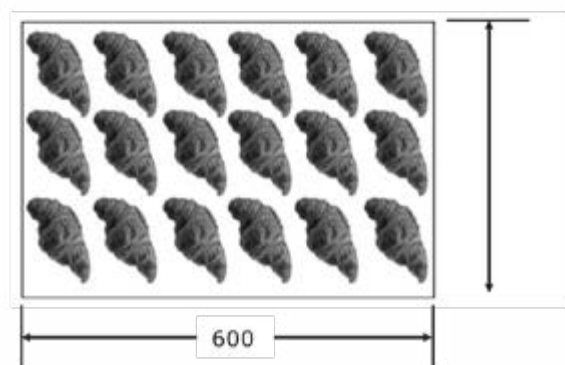



# Oven supports for rotary rack oven 6.43

Type of products	Baguettes 250 g			
Number of levels/rack	18	16	15	12
Type of trays	Mesh 6 AL 800			
Overall dimensions (mm)	460 x 800			
Capacities (indicative values)				
Pieces per mesh	6	6	6	6
Pieces per rack	108	96	90	72

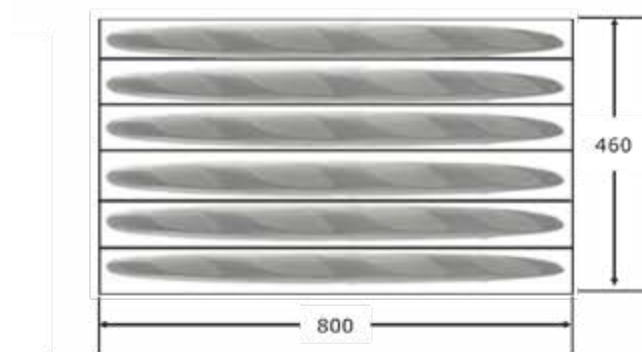

Type of products	Baguettes 250 g			
Number of levels/rack	18	16	15	12
Type of trays	Mesh 5 AL 800			
Overall dimensions (mm)	400 x 800			
Spacing between trays (mm)	90	101	108	135
Capacities (indicative values)				
Pieces per mesh	5	5	5	5
Pieces per rack	90	80	75	60

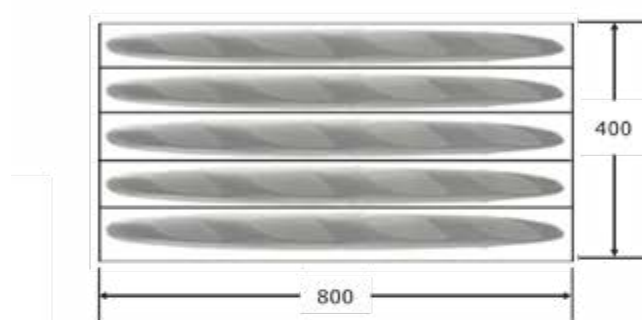

Type of products	breads 400 g			
Number of levels/rack	18	16	15	12
Type of trays	Mesh 4 AL 800			
Overall dimensions (mm)	400 x 800			
Capacities (indicative values)				
Pieces per mesh	4	4	4	4
Pieces per rack	72	94	60	48

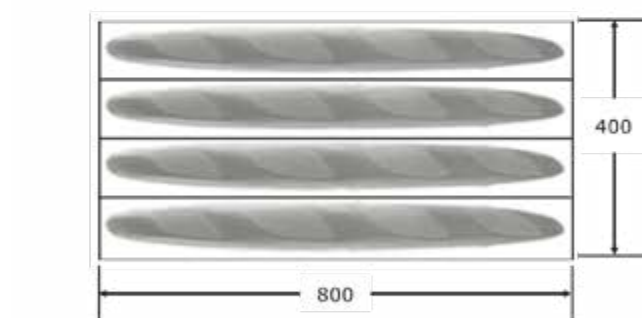

Type of products	Pastry, Danish			
Number of levels/rack	18	16	15	12
Type of trays	Baking tray			
Overall dimensions	400 x 800			
Capacities (indicative values)				
Pieces per mesh	18 - 25	18 - 25	18 - 25	18 - 25
Pieces per rack	324 - 450	288 - 400	270 - 375	216 - 300

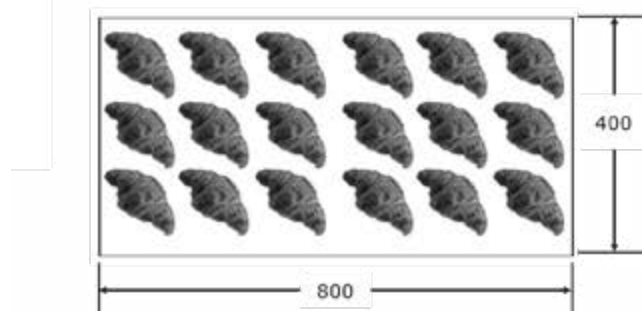

# Oven supports for rotary rack oven 8.64-12.84

<b>Type of products</b>		<b>Baguettes 250 g</b>				
<b>Number of levels/rack</b>		19	18	16	15	12
Type of trays		Mesh 8 AL 800				
Overall dimensions (mm)		600 x 800				
<b>Capacities (indicative values)</b>						
Pieces per mesh		8	8	8	8	8
Pieces per rack		152	144	128	120	96

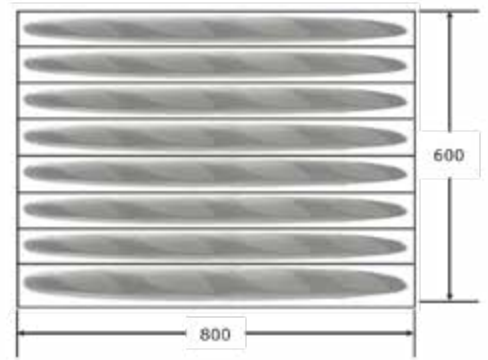

<b>Type of products</b>		<b>bread 400 g</b>				
<b>Number of levels/rack</b>		19	18	16	15	12
Type of trays		Mesh 6 AL 800				
Overall dimensions (mm)		600 x 800				
<b>Capacities (indicative values)</b>						
Pieces per mesh		6	6	6	6	6
Pieces per rack		114	108	96	90	72

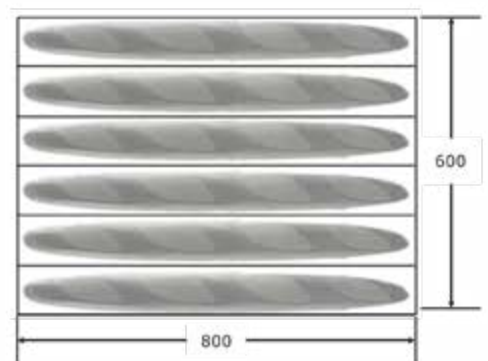

<b>Type of products</b>		<b>bread 400 g</b>				
<b>Number of levels/rack</b>		19	18	16	15	12
Type of trays		Mesh 7 AL 600				
Overall dimensions (mm)		800 x 600				
<b>Capacities (indicative values)</b>						
Pieces per mesh		7	7	7	7	7
Pieces per rack		133	126	112	105	84

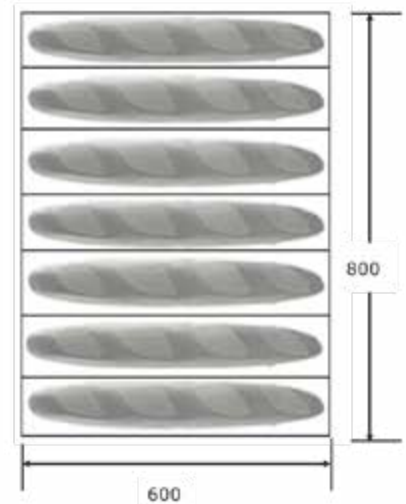

<b>Type of products</b>		<b>Pastry, Danish</b>				
<b>Number of levels/rack</b>		19	18	16	15	12
Type of trays		Baking tray (2 per level)				
Overall dimensions (mm)		400 x 600				
<b>Capacities (indicative values)</b>						
Pieces per mesh		15 - 20	15 - 20	15 - 20	15 - 20	15 - 20
Pieces per rack		570 - 760	540 - 720	480 - 640	450 - 600	360 - 480

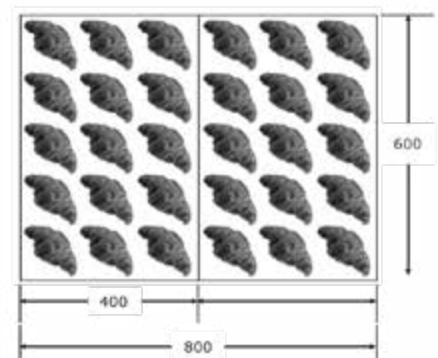

## Oven supports for rotary rack oven 8.64-12.84

Type of products		Baguettes 250 g				
Number of levels/rack		19	18	16	15	12
Type of trays		Mesh 12 AL 700				
Overall dimensions (mm)		900 x 700				
Capacities (indicative values)						
Pieces per mesh		12	12	12	12	12
Pieces per rack		228	216	192	180	144

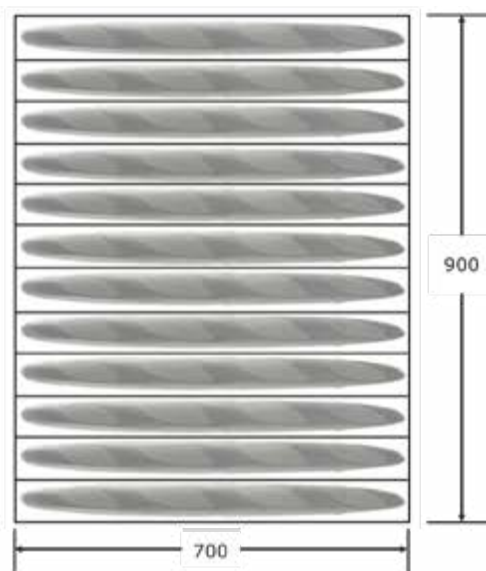

Type of products		Baguettes 250 g				
Number of levels/rack		19	18	16	15	12
Type of trays		Mesh 10 AL 700				
Overall dimensions (mm)		900 x 700				
Capacities (indicative values)						
Pieces per mesh		10	10	10	10	10
Pieces per rack		190	180	160	150	120

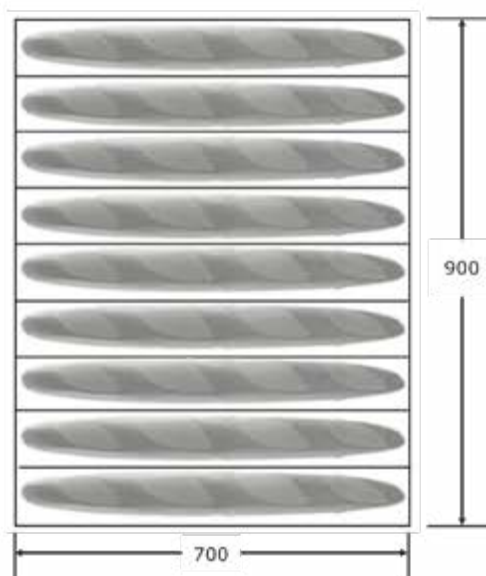

Type of products		Breads 400 g				
Number of levels/rack		19	18	16	15	12
Type of trays		Mesh 9 AL 700				
Overall dimensions (mm)		900 x 700				
Capacities (indicative values)						
Pieces per mesh		9	9	9	9	9
Pieces per rack		171	162	144	135	108

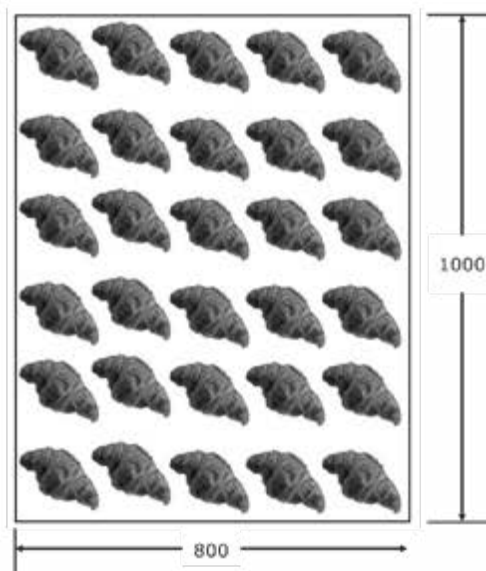

Type of products		Pastry, Danish				
Number of levels/rack		19	18	16	15	12
Type of trays		Baking tray				
Overall dimensions (mm)		1000 x 800				
Capacities (indicative values)						
Pieces per mesh		30 - 50	30 - 50	30 - 50	30 - 50	30 - 50
Pieces per rack		570-950	540-900	480-800	450-750	360-600

# Oven supports for rotary rack oven 8.84 - 10.83

<b>Type of products</b>		<b>Baguettes 250 g</b>				
<b>Number of levels/rack</b>	19	18	16	15	12	
Type of trays	Mesh 10 AL 800					
Overall dimensions (mm)	800 x 800					
<b>Capacities (indicative values)</b>						
Pieces per mesh	10	10	10	10	10	
Pieces per rack	190	180	160	150	120	

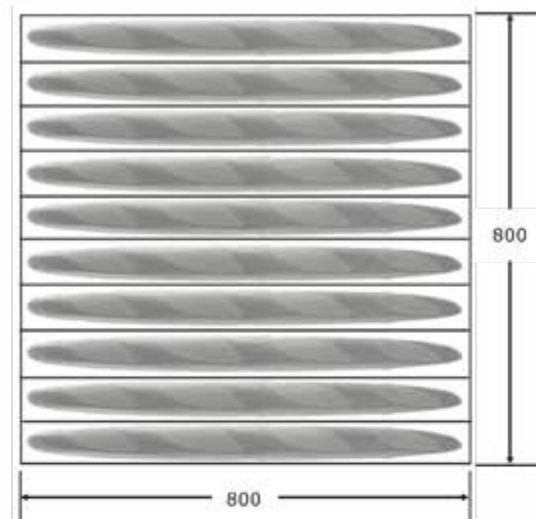

<b>Type of products</b>		<b>bread 400 g</b>				
<b>Number of levels/rack</b>	19	18	16	15	12	
Type of trays	Mesh 8 AL 800					
Overall dimensions (mm)	800 x 800					
<b>Capacities (indicative values)</b>						
Pieces per mesh	8	8	8	8	8	
Pieces per rack	152	144	128	120	96	

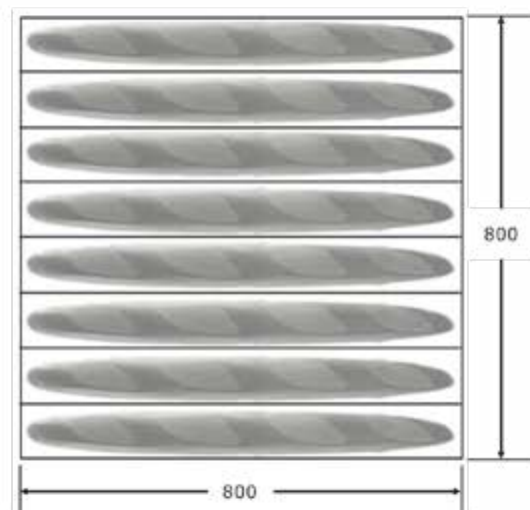

<b>Type of products</b>		<b>Pastry, Danish</b>				
<b>Number of levels/rack</b>	19	18	16	15	12	
Type of trays	Baking tray (2 per level)					
Overall dimensions (mm)	400 x 800					
<b>Capacities (indicative values)</b>						
Pieces per mesh	15-20	15-20	15-20	15-20	15-20	
Pieces per rack	684-950	648-900	576-800	540-750	432-600	

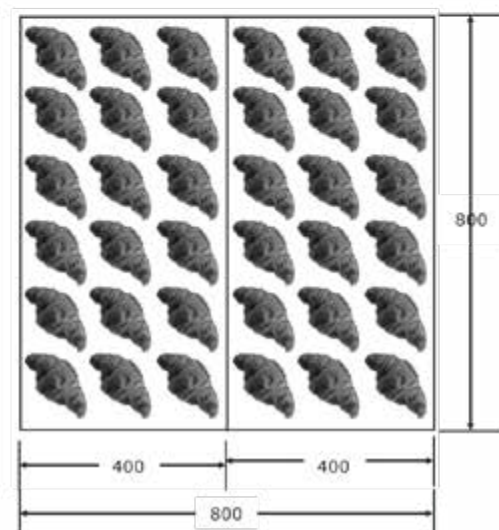

# Oven supports for rotary rack oven 10.83-12.84

Type of products		Baguettes 250 g			
Number of levels/rack	18	16	15	12	
Type of trays	Mesh 12 AL 800				
Overall dimensions (mm)	1000 x 800				
Capacities (indicative values)					
Pieces per mesh	12	12	12	12	
Pieces per rack	216	192	180	144	

Produits		Baguettes 250 g			
Number of levels/rack	18	16	15	12	
Type of trays	Mesh 10 AL 800				
Overall dimensions (mm)	1000 x 800				
Capacities (indicative values)					
Pieces per mesh	10	10	10	10	
Pieces per rack	180	160	150	120	

Produits		Breads 400 g			
Number of levels/rack	18	16	15	12	
Type of trays	Mesh 9 AL 800				
Overall dimensions (mm)	1000 x 800				
Capacities (indicative values)					
Pieces per mesh	9	9	9	9	
Pieces per rack	162	144	135	108	

Type of products		Pastry, Danish			
Number of levels/rack	18	16	15	12	
Type of trays	Baking tray				
Overall dimensions (mm)	1000 x 800				
Capacities (indicative values)					
Pieces per mesh	30 - 50	30 - 50	30 - 50	30 - 50	
Pieces per rack	540-900	480-800	450-750	360-600	

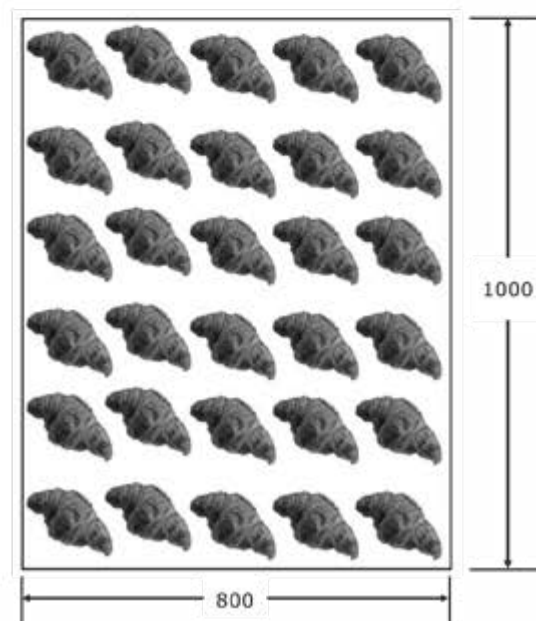
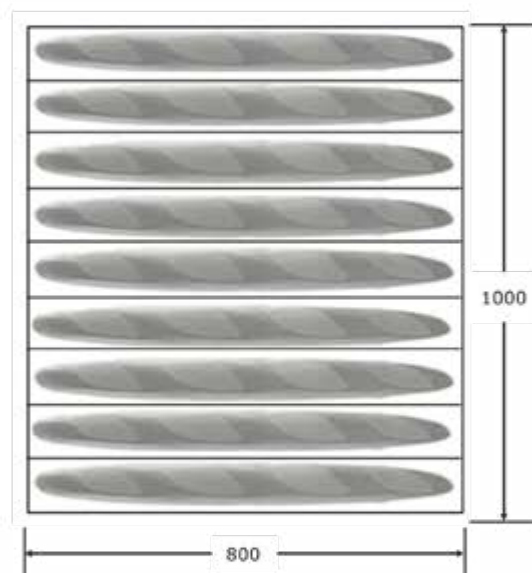
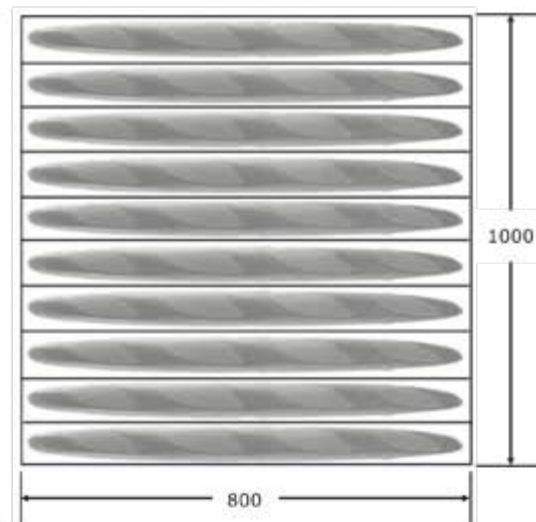

# Compact



Oven with brick cladding finish (Option)

## Annular steam tubes oven - Fuel-oil / Gas

### Performances

- Baking area :  
3.9 m<sup>2</sup> for 800/4.123 model  
4.5 m<sup>2</sup> for 800/4.143 model
- Doors of 800 mm
- Number of decks : 4
- Useful deck height :  
3 decks of 160 mm  
1 deck of 220 mm (upper deck)

### The advantages

- The most compact oven in the range
- Easy to install
- Delivered in 3 sections on legs
- Available with different claddings: stainless steel, brick or tiles
- Annular tubes guaranteed 10 years
- Refractory stainless steel fire chamber guaranteed 5 years
- Deferred start-up of the oven

### Use

The Cervap Compact is a deck oven designed to bake all types of breads, pastries and danish products. Available in one 800 mm wide door per deck, with all-stainless steel frontage or provided with white tiles or brick cladding, it is easily found in the bakery or in the shop.

### Operating principle

A watertight tube set containing water forms the exchanger and baking chambers of this oven. The tubes diffuse even heat in all points of the baking chamber and give your oven exceptional flexibility and reactivity.

### Construction

- **Front**
  - polished stainless steel
  - IDL handle 3 positions
  - removable glass doors
  - steam exhaust hood with exhaust fan
- **Baking chamber**
  - refractory plates 20 mm thick
  - halogen lighting
- **Heat exchanger**
  - 19 annular steam tubes per linear meter
  - refractory stainless steel fire chamber
  - barometric damper
- **Steam generator**
  - independent
  - 1 per deck
- **Insulation**
  - crossed rock wool panels
  - reflecting glass doors to reduce heat losses



## Annular steam tubes oven **Cervap Compact**

	<b>France</b>	<b>Export</b>
<b>Burner</b>		
Gas burner	■	■
Fuel-oil burner	□	□
<b>IDL handles side and steam button side</b>		
Left	■	■
Right	□	□
<b>Controls</b>		
Electromechanical controls on the left	■	■
Opticom controls on the left	□	□
<b>Front</b>		
Stainless steel front	■	■
Customized front (cladding not provided)	€	€
Brick coated front	€	€
White tiled coated front	€	€
<b>Steam vent (only left)</b>		
Without steam vent	■	□
Steam vent on upper deck	€	❖
Steam vent on each deck	€	■
<b>Hood - Exhaust fan</b>		
Hood without exhaust fan	■	■
Hood with exhaust fan	€	€
<b>Hooks for loader - unloader</b>		
Without	■	■
With	€	€
<b>Integrated lifter</b>		
Integrated lifter	€	€
<b>Additional options</b>		
Stainless steel outside panels	€	€
Pulsed steam injection	■	■
Brass water solenoid valve	❖	€
Water filter to prevent scale deposits	€	€
Fresh air inlet on burner	■	■
<b>Assembly</b>		
Built on site	■	■
<b>Electric power</b>		
~230 V	■	■

<b>Powe features</b>		<b>800/4.123</b>	<b>800/4.143</b>
Electrical protection	(A)	16	16
Heating power M/G	(kW)	35	40
Electric heating power	(kW)	-	-
Average gradient of temperature rise	(°C/min)	1,5 - 2	1,5 - 2
Maximum baking temperature of the oven	(°C)	280	280

# Annular steam tubes oven **Cervap Compact**

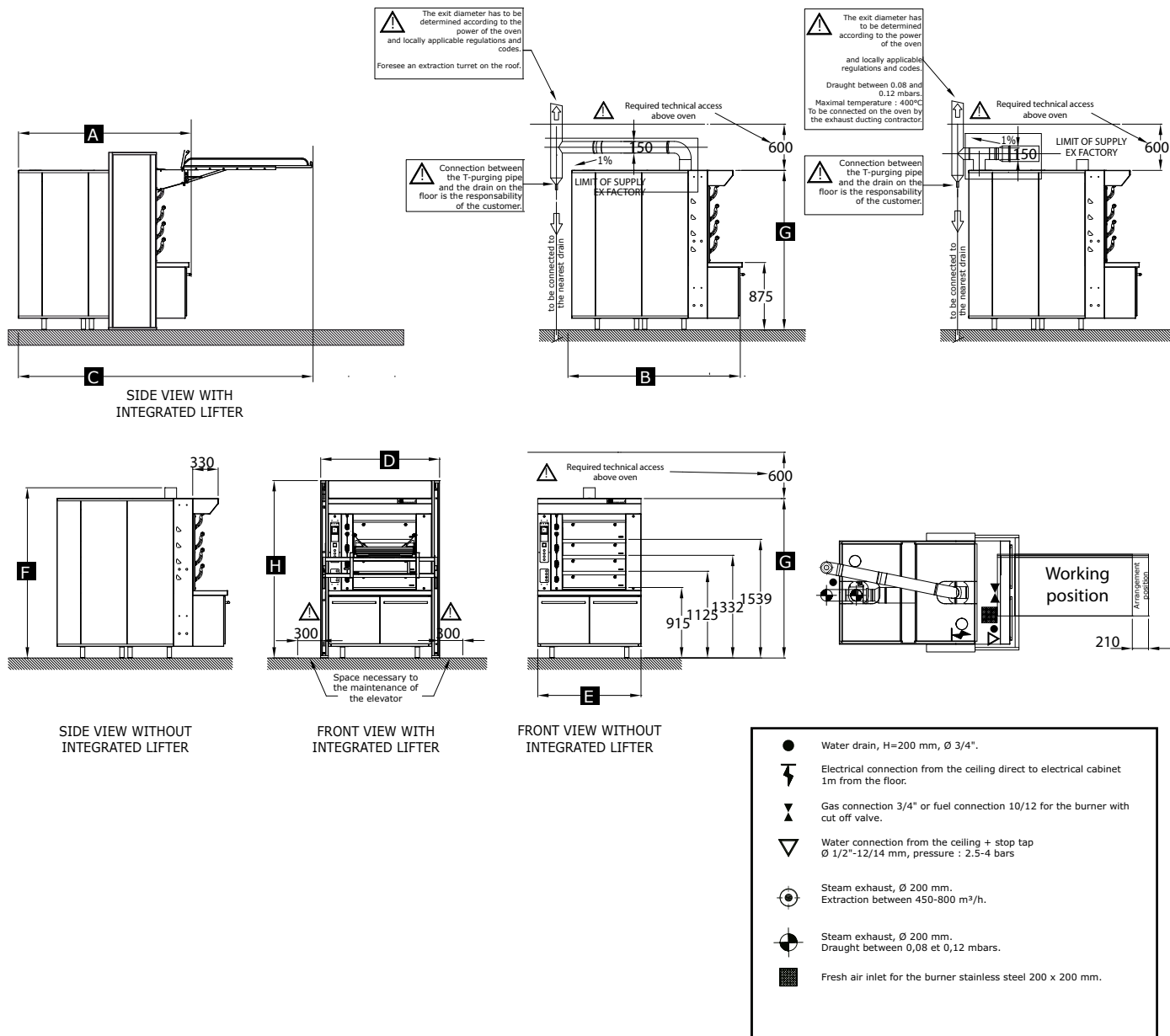

Technical features									Baking area	Floor Area	Total weight
Models	A	B	C	D	E	F	G	H			
(mm)									(1m² = 10.764 ft²)	(1m² = 10.764 ft²)	(1kg = 2.2046 Lbs)
<b>Cervap Compact 123</b>											
800/4.123	2240	2183	4228	1544	1340	2480	2069	2301	3.8	3	1350
<b>Cervap Compact 143</b>											
800/4.143	2450	2393	4808	1544	1340	2480	2069	2301	4.5	3.3	1460



# Compact GME



## Annular steam tubes ovens - Fuel-oil / Gas & Electric

### Performances

Baking area :

- 4,9 m<sup>2</sup> for 800/4.123 model
  - 5,7 m<sup>2</sup> for 800/4.143 model
- Doors of 800 mm

5 decks :

- 3 Fuel-oil/Gas decks of 160 mm (lower ones)
- 1 Fuel-oil/Gas deck of 220 mm
- 1 Electric deck of 220 mm (upper)

### The advantages

- The most compact oven in the range
- Independent electrical deck
- Easy to install
- Delivered in 3 sections on legs
- Annular tubes guaranteed 10 years
- Refractory stainless steel fire chamber guaranteed 5 years
- Deferred start-up of the oven

### Use

The Cervap Compact GME is a deck oven designed to bake all types of breads, pastries and danish products. Available in one 800 mm wide door per deck, with all-stainless steel frontage or provided with white tiles or brick cladding, it is easily found in the bakery or in the shop.

### Operating principle

A watertight tube set containing water forms the exchanger and baking chambers of this oven. The tubes diffuse even heat in all points of the baking chamber and give your oven exceptional flexibility and reactivity.

### Construction

- **Front**
  - polished stainless steel
  - IDL handle 3 positions
  - removable glass doors
  - steam exhaust hood with exhaust fan
- **Baking chamber**
  - refractory plates 20 mm thick
  - halogen lighting
- **Heat exchanger**
  - 19 annular steam tubes per linear meter
  - refractory stainless steel fire chamber
  - barometric damper
- **Steam generator**
  - independent
  - 1 per deck
- **Independent electric deck**
  - independent control for bottom and top heat
  - electrically heated steam generator
- **Isolation**
  - crossed rock wool panels
  - reflecting glass doors to reduce heat losses

## Annular steam tubes oven **Cervap Compact GME**

	<i>France</i>	<i>Export</i>
<b>Burner</b>		
Gas burner	■	■
Fuel-oil burner	□	□
<b>Heating elements</b>		
Access on the left	■	■
<b>IDL handles side and steam button side</b>		
Left	■	■
Right	□	□
<b>Controls</b>		
Electromechanical controls on the left	■	■
Opticom controls on the left	□	□
<b>Front</b>		
Stainless steel front	■	■
<b>Steam vent (only left)</b>		
Without steam vent	■	□
Steam vent on upper deck	€	❖
Steam vent on each deck	€	■
<b>Hood - Exhaust fan</b>		
Hood without exhaust fan	■	■
Hood with exhaust fan	€	€
<b>Hooks for loader - unloader</b>		
Without	■	■
with	€	€
<b>Integrated lifter</b>		
Integrated lifter	€	€
<b>Additional options</b>		
Stainless steel outside panels	€	€
Pulsed steam injection	■	■
Brass water solenoid valve	❖	€
Water filter to prevent scale deposits	€	€
Fresh air inlet on burner	■	■
<b>Assemblage</b>		
Built on site	■	■
<b>Electric power</b>		
3N~400V	■	■

<b>Power features</b>		<b>800/5.123 GME</b>	<b>800/5.143 GME</b>
Connecting power	(A)	16	16
Heating power (M/G)	(kW)	35	40
Heating power (electric)	(kW)	10,7	11,9
Average gradient of temperature rise	(°C/min)	1,5 - 2	1,5 - 2
Maximum baking temperature of the oven	(°C)	280	280

# Annular steam tubes oven **Cervap Compact GME**

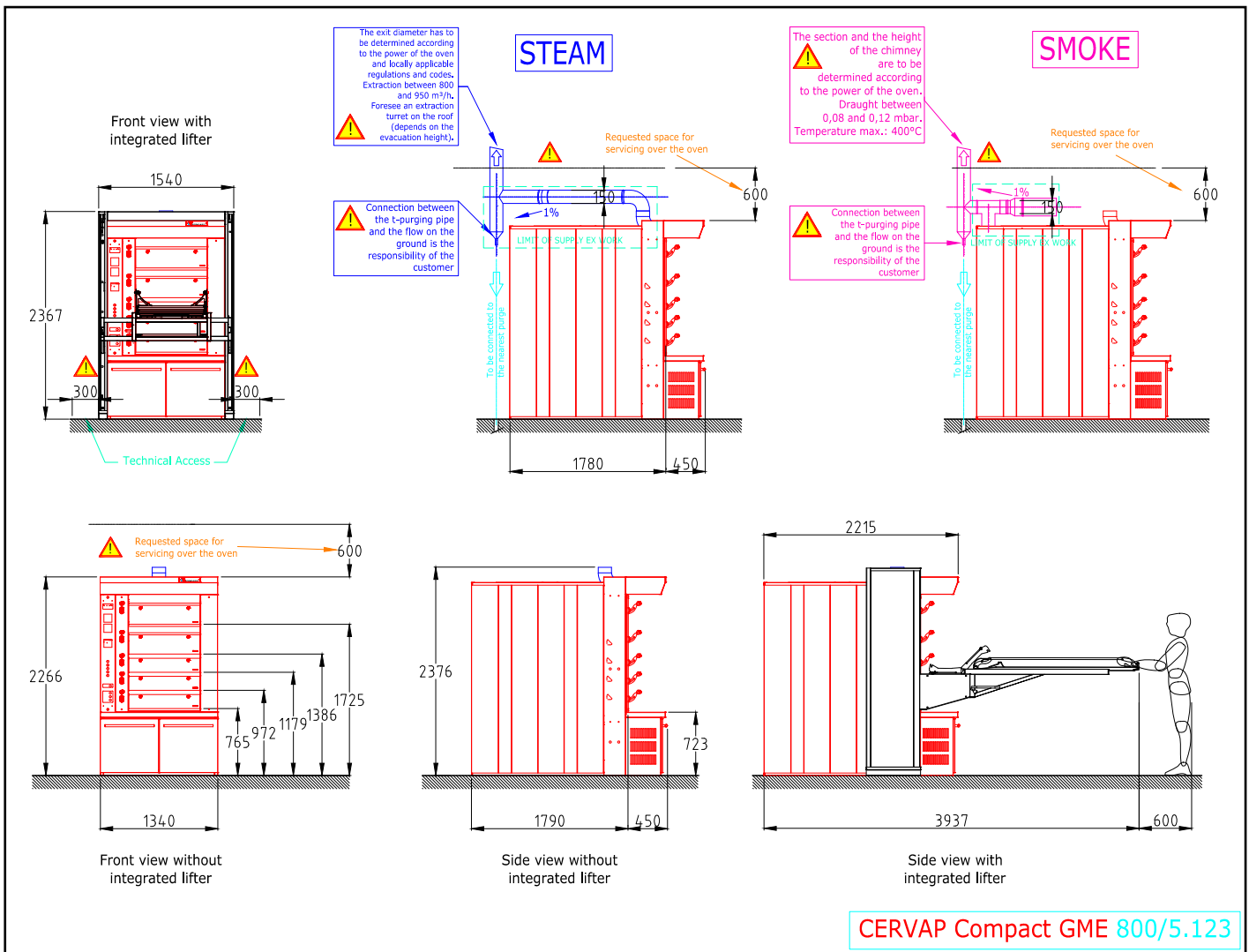

- Water drain, H=200 mm, Ø 3/4".
- ⚡ Electrical connection from the ceiling direct to electrical cabinet 1m from the floor.
- ⌵ Gas connection 3/4" or fuel connection 10/12 for the burner with cut off valve..
- ▽ Water connection from the ceiling + stop tap Ø 1/2"-12/14 mm, pressure : 2.5-4 bars
- ⊙ Steam exhaust, Ø 200 mm. Extraction between 450-800 m<sup>3</sup>/h.
- ⊙ Steam exhaust, Ø 200 mm. Draught between 0,1 et 0,2 mbars.
- Fresh air inlet for the burner stainless steel 200 x 200 mm.

**Technical features**

	A	B	C	D	E	F	G	H		Total weight	
<b>Models</b>									<b>Baking area</b>	<b>Floor Area</b>	
									(1m <sup>2</sup> = 10.764 ft <sup>2</sup> )	(1m <sup>2</sup> = 10.764 ft <sup>2</sup> )	(1kg= 2.2046 Lbs)
	<b>(mm)</b>										
<b>Cervap Compact GME 123</b>											
800/5.123	2240	2183	4228	1544	1340	2630	2266	2367	4.8	3	1750
<b>Cervap Compact GME 143</b>											
800/5.143	2450	2393	4808	1544	1340	2630	2266	2367	5.6	3.3	1860

# Cervap RS



## Annular steam tubes oven - Fuel-oil / Gas

### Performances

Baking area:

- 6,3 m<sup>2</sup> for model 800/5.160
- 7,9 m<sup>2</sup> for model 800/5.200
- 9,6 m<sup>2</sup> for model 1200/5.160
- 12 m<sup>2</sup> for model 1200/5.200

Useful height on each deck : 200 mm

Number of decks : 5

Number of doors : 1 per deck

### The advantages

- Very good energy yield
- Generous steam production adapted for « brotchens »
- Easy to install
- Delivered in sections for easy assembly
- Annular tubes 10 years warranty
- Refractory stainless steel fire chamber guaranteed 5 years
- Deferred startup of the oven

### Use

The Cervap RS is a deck oven designed to bake all types of breads, pastries and Danish products. Small in size, it is suitable for all bakeries, even the most cramped.

### Operating principle

A watertight tube set containing water forms the exchanger and baking chambers of this oven. The energy produced by the burner is used three times: firstly to heat the fire chamber with the flame, secondly by heating the tubes with the combustion gases and thirdly by combustion gases passing through the steam generator. The tubes diffuse even heat in all points of the baking chamber and give your oven exceptional flexibility and reactivity.

### Construction

#### • **Front**

- polished stainless steel
- « pull and push » door handle, 2 positions
- removable glass doors
- steam exhaust hood with exhaust fan

#### • **Baking chamber**

- refractory concrete hearth plates 20 mm thick
- halogen lighting

#### • **Heat exchanger**

- 24 simple loop annular tubes per linear meter
- refractory stainless steel fire chamber
- barometric damper

#### • **Steam generator**

- placed under the oven
- heated with recovery of combustion gases
- composed of 5 independently functioning compartments

#### • **Insulation**

- crossed rock wool panels
- reflecting glass doors to reduce heat losses

## Annular steam tubes oven **Cervap RS**

	<i>France</i>	<i>Export</i>
<b>Burner</b>		
Gas burner	■	■
Fuel-oil burner	□	□
<b>Door handle side</b>		
Pull and push door handle	■	■
<b>Control</b>		
Electronichal control Sensitiv' on the right side	■	■
<b>Steam vent (only left)</b>		
Steam vent on each deck	■	■
<b>Steam generator</b>		
Dual steam push button	■	■
<b>Hood - Exhaust fan</b>		
Hood with exhaust fan	■	■
<b>Hooks for loader - unloader</b>		
Without	■	■
<b>Divers</b>		
Pulsed steam injection	■	■
Brass water solenoid valve	■	■
Water filter to prevent scale deposits	€	€
Fresh air inlet on burner	■	■
Stainless steel outside panels	€	€
<b>Assembly</b>		
Built on site	■	■
<b>Electric power</b>		
~230 V	■	■

<b>Power features</b>		<b>1200/5.160</b>		<b>1200/5.200</b>	
<b>Models</b>		<b>800/5.160</b>	<b>800/5.200</b>	<b>1200/5.160</b>	<b>1200/5.200</b>
Electric supply	(kW)	0,8	0,8	0,8	0,8
Heating power M/G	(kW)	42	54	55	68
Electric heating power	(kW)	-	-	-	-
Average gradient of temperature rise	(°C/min)	1,5 - 2			
Maximum baking temperature of the oven	(°C)	280			

# Annular steam tubes oven **Cervap RS**

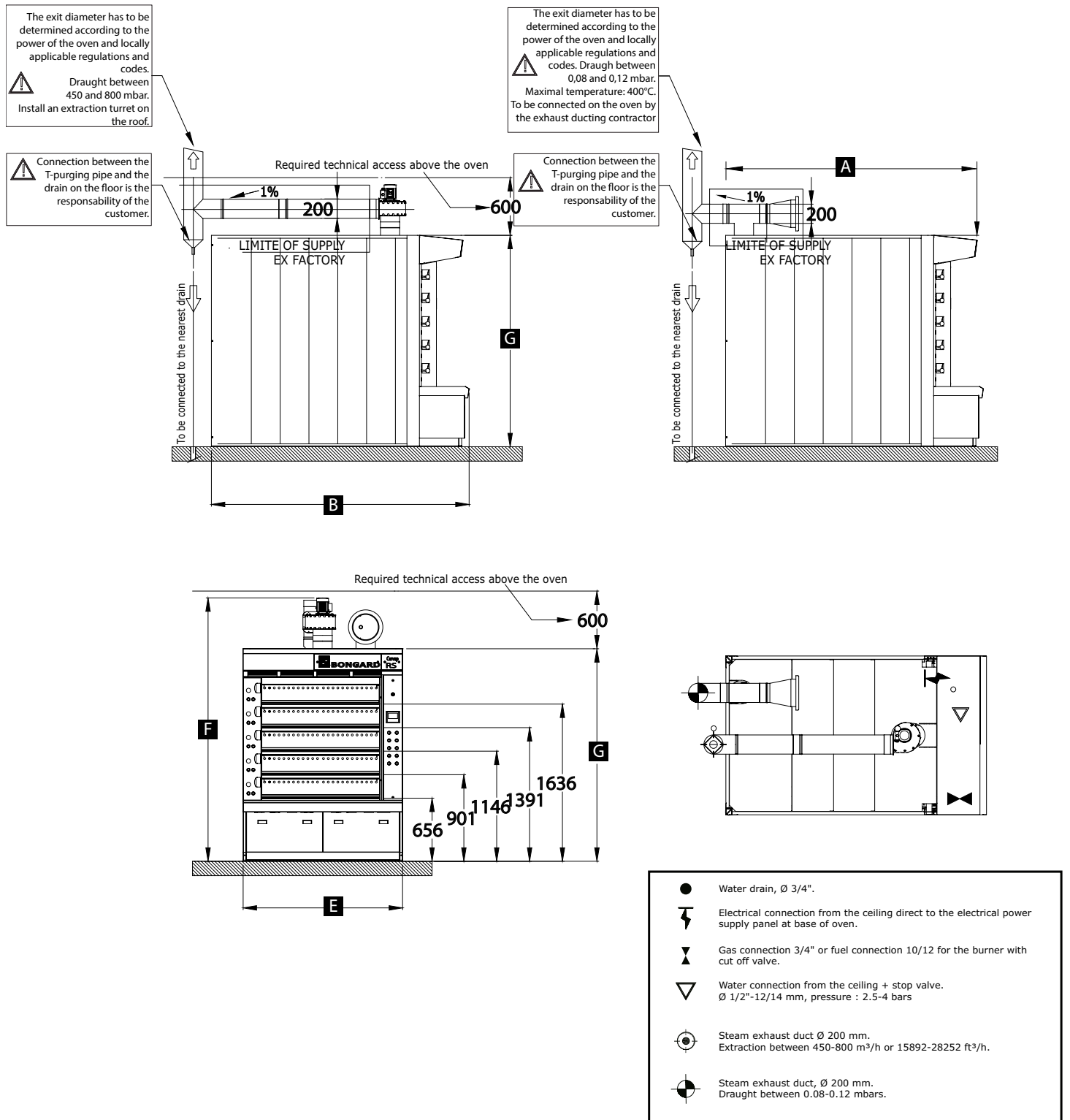

<b>Technical features</b>						
	<b>Oven dimensions</b>		<b>800/5.160</b>	<b>800/5.200</b>	<b>1200/5.160</b>	<b>1200/5.200</b>
<b>A</b>	Depth with hood	(mm)	2726	3087	2726	3087
<b>B</b>	Depth on the floor	(mm)	2679	3040	2679	3040
<b>E</b>	Width on the floor	(mm)	1250	1250	1660	1660
<b>F</b>	Total height, overall	(mm)	2700	2700	2700	2700
<b>G</b>	Total height, oven front	(mm)	2200	2200	2200	2200
	Baking area (1m²=10.764 ft²)	(m²)	6,4	8,1	9,8	12,3
	Floor area	(m²)	3,4	3,6	4,52	5,1
	Net weight	(kg)	2000	2300	2900	3600

# Cervap



## Annular steam tubes oven - Fuel-oil / Gas

### Performances

- Baking area : from 4.5 to 24 m<sup>2</sup>
- Useful height on each deck : 185 mm
- Number of decks : 3 or 4
- Doors of 600 or 750 mm
- Number of doors : 1 to 3 per deck

### The advantages

- Very extensive oven range
- Exceptional energy yield
- Identical baking to traditional masonry ovens
- Delivered in sections for ease of installation
- Annular tubes guaranteed 10 years
- Refractory stainless steel fire chamber guaranteed 5 years
- Deferred start-up of the oven

### Use

The Cervap is a deck oven designed to bake all types of breads, pastries and Danish products. Available in 1, 2 and 3 doors per deck, there is a CERVAP for each bakery, even the most cramped.

### Operating principle

A watertight tube set containing water forms the exchanger and baking chambers of this oven. The energy produced by the burner is used two times: firstly to heat the fire chamber with the flame and secondly by heating the tubes with the combustion gases. The tubes diffuse even heat in all points of the baking chamber and give your oven exceptional flexibility and reactivity.

### Construction

- **Front**
  - polished stainless steel
  - « F » door handle, 3 positions
  - removable glass doors
  - steam exhaust hood with exhaust fan
- **Baking chamber**
  - refractory concrete hearth plates 20 mm thick
  - halogen lighting
- **Heat exchanger**
  - 24 single loop annular tubes per linear meter
  - refractory stainless steel fire chamber
  - barometric damper
- **Insulation**
  - crossed rock wool panels
  - reflecting glass doors to reduce heat losses

# Annular steam tubes oven **Cervap**

	France	Export
<b>Burner</b>		
Gas burner	■	■
Fuel-oil burner	□	□
<b>"F" door handles</b>		
1 door handle on the left	■	■
2 door handles - 1 on the left - 1 on the right	■	■
3 door handles - 2 on the left - 1 on the right	■	■
<b>Control</b>		
Electromechanical interface on the left	■	■
Opticom control on the left	□	□
<b>Steam vent (only left)</b>		
Without steam vent	■	□
Steam vent on upper deck	€	❖
Steam vent on each deck	€	■
<b>Steam generator</b>		
Reinforced steam generator	€	■
<b>Steam generator control</b>		
Single steam push button	■	■
Dual steam push button on each deck + mechanical timer	€	€
<b>Hood - Exhaust fan</b>		
Hood without Exhaust fan	-€	-€
Hood with exhaust fan	■	■
<b>Hooks for loader - unloader</b>		
without	■	■
with	€	€
<b>Integrated lifter</b>		
Integrated lifter	€	€
Column cover in light grey painting	■	■
Column cover in stainless steel	□	□
<b>Additional options</b>		
Screen for top heat (50% on upper deck)	€	€
Adaptation for integrated lifter	□	□
Brass water solenoid valve	❖	€
Pulsed steam injection	■	■
Water filter to prevent scale deposits	€	€
Fresh air inlet on burner	■	■
<b>Assembly</b>		
Built on site	■	■
<b>Electric power</b>		
~230V	■	■

Technical features		
Models	Electric power (A)	Heating power Fuel-oil or Gas (1kW=860.4 kcal/h 1kW=3415 BTU)
<b>Cervap - 2 x 600 mm - 3 decks</b>		
600/6.164	16	47,7
600/6.186	16	52
600/6.201	16	54
600/6.222	16	64
600/6.259	16	70,9
<b>Cervap - 2 x 600 mm - 4 decks</b>		
600/8.164	16	64
600/8.186	16	68
600/8.201	16	72
600/8.222	16	76
600/8.259	16	82,6
<b>Cervap - 3 x 600 mm - 3 decks</b>		
600/9.186	16	77,9
600/9.222	16	82,6
600/9.259	16	95,4
<b>Cervap - 3 x 600 mm - 4 decks</b>		
600/12.186	16	95,4
600/12.201	16	107
600/12.222	16	118,6
600/12.259	0	0

Technical features		
Models	Electric power (A)	Heating power Fuel-oil or Gas (1kW=860.4 kcal/h 1kW=3415 BTU)
<b>Cervap - 1 x 750 mm - 4 decks</b>		
750/4.149	16	42
750/4.186	16	47,7
750/4.222	16	54
750/4.259	16	64
<b>Cervap - 2 x 750 mm - 3 decks</b>		
750/6.186	16	70,9
750/6.222	16	77,9
750/6.259	16	82,6
<b>Cervap - 2 x 750 mm - 4 decks</b>		
750/8.186	16	77,9
750/8.222	16	87,2
750/8.259	16	95,4



# Annular steam tubes ovens Cervap - door 600mm

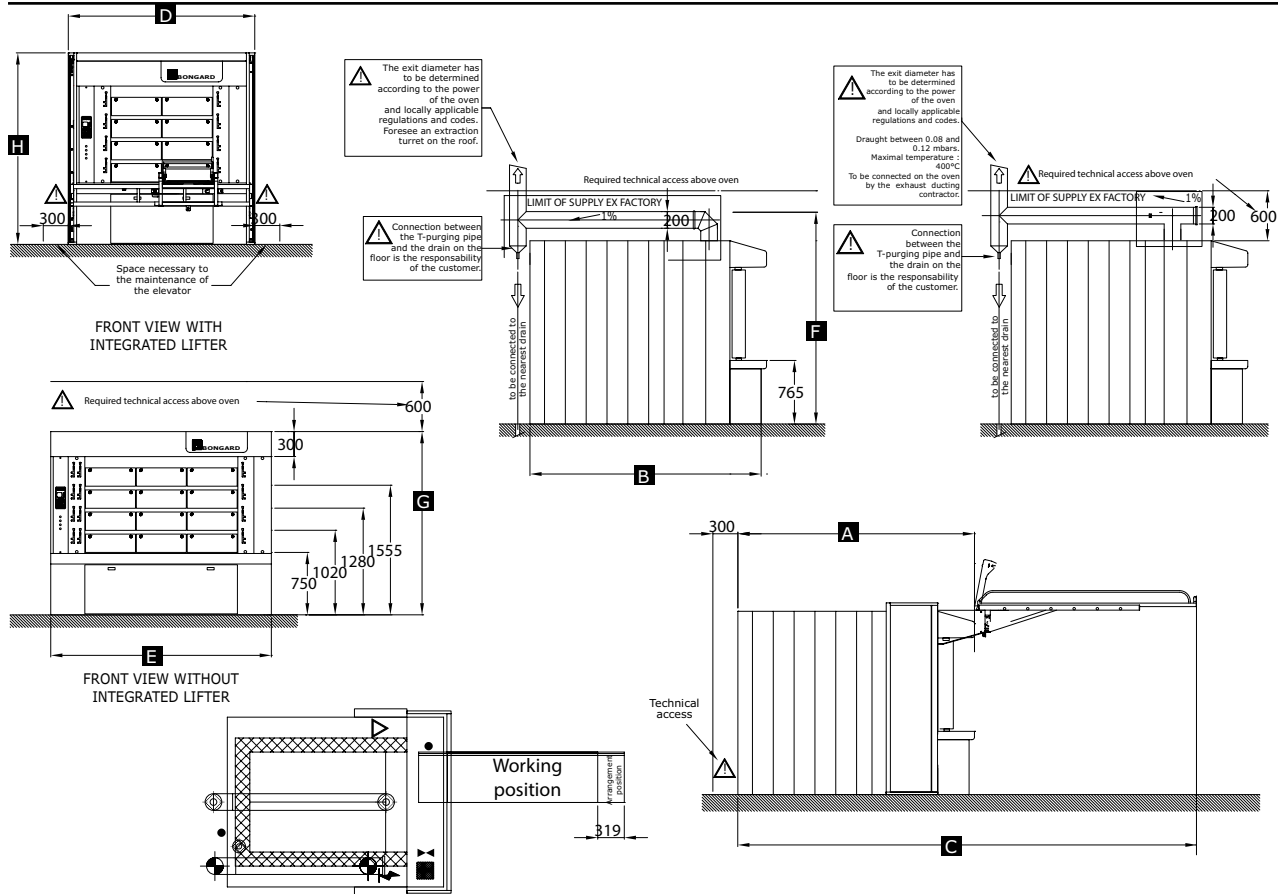

## Technical features

Models	A	B	C	D	E	F	G	H	Baking area (1m <sup>2</sup> = 10.764 ft <sup>2</sup> )	Floor Area (1m <sup>2</sup> = 10.764 ft <sup>2</sup> )	Total weight (1kg = 2.2046 Lbs)
(mm)											
<b>Cervap - 2 x 600 mm - 3 decks</b>											
600/6.164	2596	2539	4987	2242	2038	2700	2200	2301	5,9	5,2	2800
600/6.186	2836	2779	5597	2242	2038	2700	2200	2301	6,7	5,7	3150
600/6.201	2976	2919	5737	2242	2038	2700	2200	2301	7,2	6	3400
600/6.222	3216	3159	6366	2242	2038	2700	2200	2301	8	6,5	3600
600/6.259	3596	3539	ND	2242	2038	2700	2200	2301	9,4	7,3	4000
<b>Cervap - 2 x 600 mm - 4 decks</b>											
600/8.164	2596	2539	4987	2242	2038	2700	2200	2301	7,9	5,2	3750
600/8.186	2836	2779	5597	2242	2038	2700	2200	2301	8,9	5,7	4000
600/8.201	2976	2919	5737	2242	2038	2700	2200	2301	9,6	6	4300
600/8.222	3216	3159	6366	2242	2038	2700	2200	2301	10,7	6,5	4500
600/8.259	3596	3539	ND	2242	2038	2700	2200	2301	12,6	7,3	5000
<b>Cervap - 3 x 600 mm - 3 decks</b>											
600/9.186	2836	2779	5597	2858	2654	2700	2200	2301	10	7,4	4500
600/9.222	3216	3159	6366	2858	2654	2700	2200	2301	12,1	8,4	5000
600/9.259	3596	3539	ND	2858	2654	2700	2200	2301	14,2	9,4	5500
<b>Cervap - 3 x 600 mm - 4 decks</b>											
600/12.186	2836	2779	5597	2858	2654	2700	2200	2301	13,4	7,4	6000
600/12.201	2976	2919	5737	2858	2654	2700	2200	2301	14,5	7,8	6400
600/12.222	3216	3159	6366	2858	2654	2700	2200	2301	16,1	8,4	6700
600/12.259	3596	3539	ND	2858	2654	2700	2200	2301	18,9	9,4	7500

# Annular steam tubes ovens Cervap - door 750mm

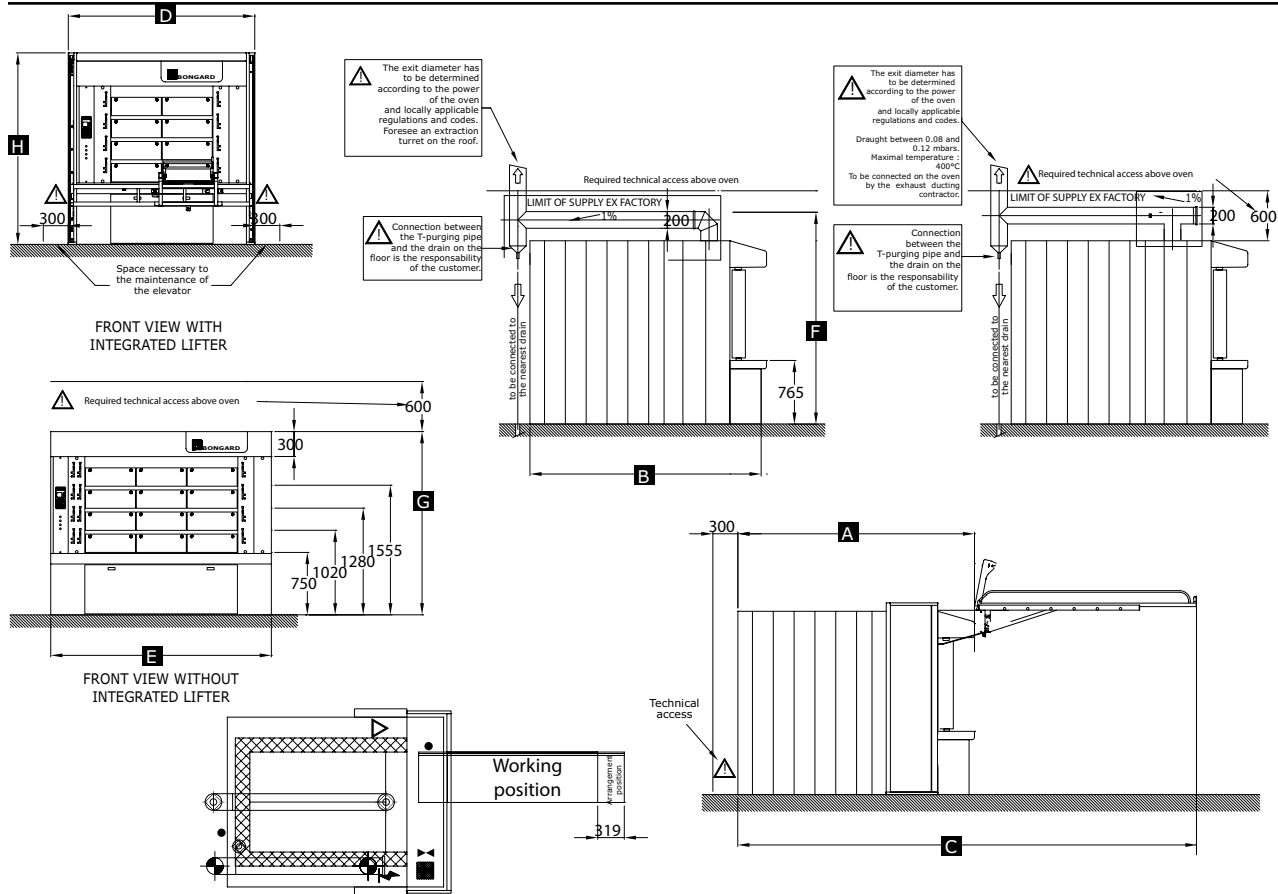

- Water drain, H=200 mm, Ø 3/4".
- ⚡ Electrical connection from the ceiling direct to electrical cabinet 1m from the floor.
- ⚡ Gas connection 3/4" or fuel connection 10/12 for the burner with cut off valve.
- ▽ Water connection from the ceiling + stop tap Ø 1/2"-12/14 mm, pressure : 2.5-4 bars
- ⊙ Steam exhaust, Ø 200 mm. Extraction between 450-800 m³/h.
- ⊙ Steam exhaust, Ø 200 mm. Draught between 0,08 et 0,12 mbars.
- Fresh air inlet for the burner stainless steel 200 x 200 mm.

## Technical features

Models	A	B	C	D	E	F	G	H	Baking area (1m²= 10.764 ft²)	Floor Area (1m²= 10.764 ft²)	Total weight (1kg= 2.2046 Lbs)
--------	---	---	---	---	---	---	---	---	-------------------------------	------------------------------	--------------------------------

### Cervap - 1 x 750 mm - 4 decks

750/4.149	2456	2399	4847	1768	1564	2700	2200	2301	4,3	3,8	2600
750/4.186	2836	2779	5597	1768	1564	2700	2200	2301	5,5	4,4	3000
750/4.222	3216	3159	6366	1768	1564	2700	2200	2301	6,6	5	3700
750/4.259	3596	3539	ND	1768	1564	2700	2200	2301	7,7	5,6	4250

### Cervap - 2 x 750 mm - 3 decks

750/6.186	2836	2779	5597	2526	2322	2700	2200	2301	8,2	6,5	4100
750/6.222	3216	3159	6366	2526	2322	2700	2200	2301	9,9	7,4	4700
750/6.259	3596	3539	ND	2526	2322	2700	2200	2301	11,6	8,3	5200

### Cervap - 2 x 750 mm - 4 decks

750/8.186	2836	2779	5597	2526	2322	2700	2200	2301	11	6,5	4000
750/8.222	3216	3159	6366	2526	2322	2700	2200	2301	13,3	7,4	5000
750/8.259	3596	3539	ND	2526	2322	2700	2200	2301	15,5	8,3	6000

# Cervap DT



## Annular steam tubes oven - Fuel-oil / Gas

### Performances

- Baking area : from 6 to 24 m<sup>2</sup>
- Useful height on each deck : 200 mm
- Number of decks : 3 or 4
- Doors of 600 or 750 mm
- Number of doors : 2 to 3 per deck

### The advantages

- Oven particularly designed for intensive use
- Exceptional energy yield
- Double layer of tubes on the baking decks
- Double steam generator
- Annular tubes guaranteed 10 years
- Refractory stainless steel firechamber guaranteed 5 years
- Deferred startup of the oven

### Use

The Cervap DT is a deck oven designed to bake all types of breads, pastries and Danish products.

### Operating principle

A watertight tube set containing water forms the exchanger and baking chambers of this oven. The energy produced by the burner is used two times: firstly to heat the fire chamber with the flame and secondly by heating the tubes with the combustion gases. The tubes diffuse even heat in all points of the baking chamber and give your oven exceptional flexibility and reactivity.

### Construction

- **Front**
  - polished stainless steel
  - « F » door handle, 3 positions
  - removable glass doors
  - steam exhaust hood with exhaust fan
- **Baking chamber**
  - refractory concrete hearth plates 20 mm thick
  - halogen lighting
- **Heat exchanger**
  - 24 single loop annular tubes per linear meter
  - refractory stainless steel fire chamber
  - barometric damper
- **Steam generator on all models**
  - independent, located inside of deck
  - 2 per deck
- **Isolation**
  - crossed rock wool panels
  - reflecting glass doors to reduce heat losses

# Annular steam tubes oven **Cervap DT**

	France	Export
<b>Burner</b>		
Gas burner	■	■
Fuel-oil burner	□	□
<b>"F" door handles</b>		
2 doors : 1 on the left - 1 on the right	■	■
<b>Controls</b>		
Electromechanical interface on the left	■	■
Opticom controls on the left	□	□
<b>Steam vent (only left)</b>		
Double steam vent on each deck	■	■
<b>Steam generator</b>		
Reinforced steam generator	€	■
<b>Steam generator control</b>		
Single steam push button	■	■
<b>Hood - Exhaust fan</b>		
Hood without exhaust fan	€	€
Hood with exhaust fan	■	■
<b>Hooks for loader - unloader</b>		
Without	■	■
With	€	€
<b>Integrated lifter</b>		
Integrated lifter	€	€
Column cover in light grey painting	■	■
Column cover in stainless steel	□	□
<b>Additional options</b>		
Adaptation for integrated lifter	□	□
Brass water solenoid valve	❖	€
Pulsed steam injection	■	■
Water filter to prevent scale deposits	€	€
Fresh air inlet on burner	■	■
<b>Assembly</b>		
Built on site	■	■
<b>Electric power</b>		
~230V	■	■

<b>Technical features</b>		
<b>Models</b>	<b>Electrical protection (A)</b>	<b>Heating power Fueloil or Gas (1kW=860,4 kcal/h 1kW=3415 BTU)</b>
<b>Cervap DT - 2 x 600 mm - 3 decks</b>		
600/6.184	16	52
600/6.205	16	54
<b>Cervap DT - 2 x 600 mm - 4 decks</b>		
600/8.169	16	64
600/8.184	16	68
600/8.205	16	72
600/8.242	16	82,6
<b>Cervap DT - 2 x 750 mm - 3 decks</b>		
750/6.184	16	70,9
750/6.205	16	77,9
750/6.242	16	82,6
<b>Cervap DT - 2 x 750 mm - 4 decks</b>		
750/8.184	16	78
750/8.205	16	87
750/8.242	16	95

# Annular steam tubes oven **Cervap DT**

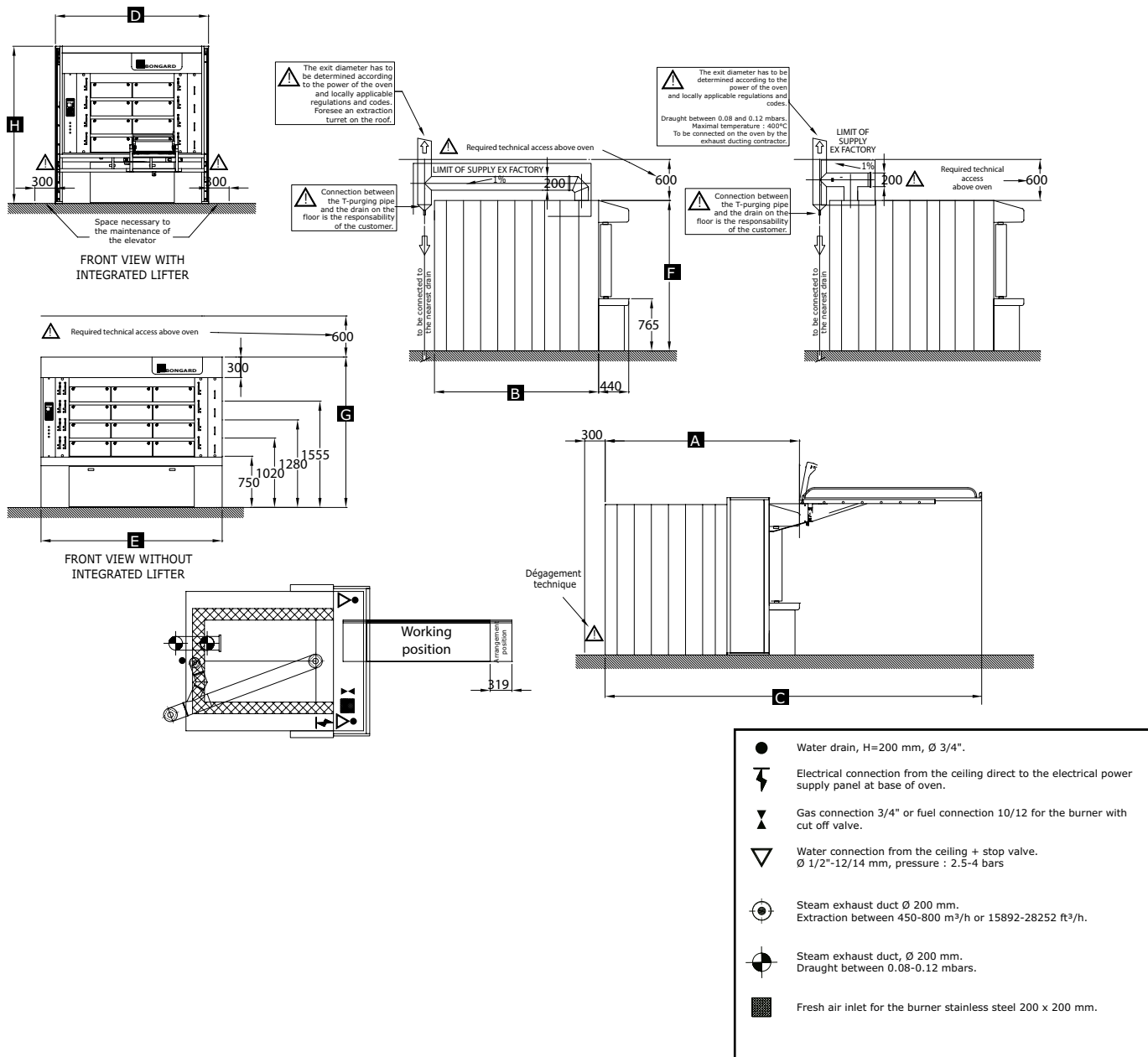

- Water drain, H=200 mm, Ø 3/4".
- ⚡ Electrical connection from the ceiling direct to the electrical power supply panel at base of oven.
- ⚙ Gas connection 3/4" or fuel connection 10/12 for the burner with cut off valve.
- ▽ Water connection from the ceiling + stop valve. Ø 1/2"-12/14 mm, pressure : 2.5-4 bars
- ⊕ Steam exhaust duct, Ø 200 mm. Extraction between 450-800 m³/h or 15892-28252 ft³/h.
- ⊖ Steam exhaust duct, Ø 200 mm. Draught between 0.08-0.12 mbars.
- Fresh air inlet for the burner stainless steel 200 x 200 mm.

Technical features											
Models	A	B	C	D	E	F	G	H		Baking area	Floor Area
(mm)										(m²)	
<b>Cervap DT - 2 x 600 mm - 3 decks</b>											
600/6.184	3086	3029	5847	2242	2038	2700	2200	2301		6,7	6,2
600/6.205	3326	3269	6087	2242	2038	2700	2200	2301		7,4	6,7
<b>Cervap DT - 2 x 600 mm - 4 decks</b>											
600/8.169	2946	2889	5337	2242	2038	2700	2200	2301		8,1	5,9
600/8.184	3086	3029	5847	2242	2038	2700	2200	2301		8,9	6,2
600/8.205	3326	3269	6087	2242	2038	2700	2200	2301		9,9	6,7
600/8.242	3706	3649	6856	2242	2038	2700	2200	2301		11,7	7,5
<b>Cervap DT - 2 x 750 mm - 3 decks</b>											
750/6.184	3086	3029	5847	2526	2322	2700	2200	2301		8,2	7,1
750/6.205	3326	3269	6087	2526	2322	2700	2200	2301		9,1	7,6
750/6.242	3706	3649	6856	2526	2322	2700	2200	2301		10,8	8,5
<b>Cervap DT - 2 x 750 mm - 4 decks</b>											
750/8.184	3086	3029	5847	2526	2322	2700	2200	2301		11	7,1
750/8.205	3326	3269	6087	2526	2322	2700	2200	2301		12,2	7,6
750/8.242	3706	3649	6856	2526	2322	2700	2200	2301		14,4	8,5

# Cervap XT



## Annular steam tubes oven - Fuel-oil / Gas

### Performances

- Baking area : from 12,3 to 18,5 m<sup>2</sup>
- Useful height on each deck : 200 mm
- Number of decks : 4
- Doors of 600 or 750 mm
- Number of doors : 2 to 3 per deck

### The advantages

- Oven particularly designed for intensive use
- Exceptional energy yield
- Double steam generator on each deck
- Possibility of installing a 3rd steam generator under the oven
- Annular tubes guaranteed 10 years
- Refractory stainless steel fire chamber guaranteed 5 years
- Deferred start-up of the oven

### Use

The Cervap XT is a deck oven designed to bake all types of breads, pastries and Danish products. Available in 2 and 3 doors per deck, it is particularly reactive and designed for intensive uses.

### Operating principle

A watertight tube set containing water forms the exchanger and baking chambers of this oven. The energy produced by the burner is used two times: firstly to heat the fire chamber with the flame and secondly by heating the tubes with the combustion gases. The tubes diffuse even heat in all points of the baking chamber and give your oven exceptional flexibility and reactivity.

### Construction

- **Front**
  - polished stainless steel
  - IDL door handles, 3 positions
  - removable glass doors
  - steam exhaust hood with exhaust fan
  - square edged oven bench (2 mm)
  - S/S cover between decks in 2 mm thickness
- **Baking chamber**
  - refractory concrete hearth plates 20 mm thick
  - halogen lighting
- **Heat exchanger**
  - 24 single loop annular tubes per linear meter
  - refractory stainless steel fire chamber
  - barometric damper
- **Steam generator on all models**
  - independent located inside of deck
  - 2 per deck
- **Insulation**
  - crossed rock wool panels
  - reflecting glass doors to reduce heat losses

# Annular steam tubes oven **Cervap XT**

	France	Export
<b>Burner</b>		
Gas burner	■	■
Oil burner	□	□
<b>"IDL" door handles</b>		
Doors of 600 : 2 on the left, 1 on the right	■	■
Doors of 750 : 1 on the left, 1 on the right	■	■
<b>Controls</b>		
Electromechanical interface on the left	■	■
Opticom controls on the left	□	□
<b>Steam vent (only left)</b>		
Steam vent on each deck	■	■
<b>Steam generator</b>		
Reinforced steam generator	■	■
3rd steam generator placed under the oven	€	€
<b>Hood - Exhaust hood</b>		
Hood without exhaust hood	€	€
Hood with exhaust fan	■	■
<b>Hooks for loader - unloader</b>		
Without	■	■
With	€	€
<b>Integrated lifter</b>		
Integrated lifter	€	€
Column cover in light grey painting	■	■
Column cover in stainless steel	□	□
<b>Additional options</b>		
Adaptation for integrated lifter	□	□
Pulsed steam injection	■	■
Brass water solenoid valve	■	■
Water filter to prevent scale deposits	€	€
Fresh air inlet on burner	■	■
<b>Assembly</b>		
Built on site	■	■
<b>Electric power</b>		
~230V	■	■

<b>Technical features</b>		
<b>Models</b>	<b>Electric power</b> (1kW=860.4 kcal/h 1kW=3415 BTU)	<b>Heating power</b> Fuel-oil or Gas (1kW=860.4 kcal/h 1kW=3415 BTU)
<b>Cervap XT - 3 x 600 mm - 4 decks</b>		
600/12.205	16	95
600/12.220	16	100
600/12.242	16	119
600/12.257	16	124
<b>Cervap XT - 2 x 750 mm - 4 decks</b>		
750/8.205	16	83
750/8.220	16	87
750/8.242	16	95
750/8.257	16	100

# Annular steam tubes oven **Cervap XT**

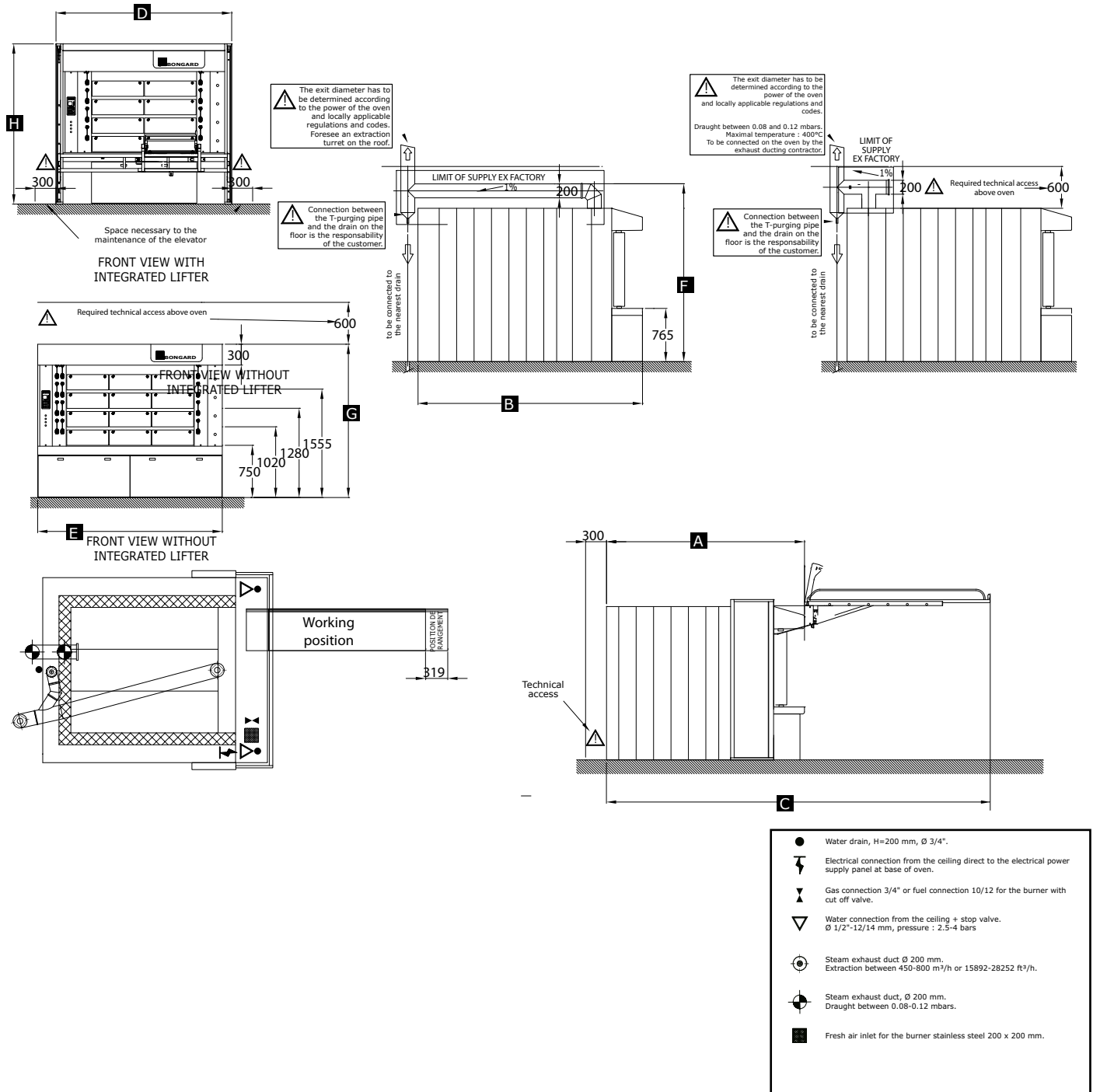

- Water drain, H=200 mm, Ø 3/4".
- ⚡ Electrical connection from the ceiling direct to the electrical power supply panel at base of oven.
- ⌘ Gas connection 3/4" or fuel connection 10/12 for the burner with cut off valve.
- ▽ Water connection from the ceiling + stop valve. Ø 1/2"-12/14 mm, pressure : 2.5-4 bars.
- ⊙ Steam exhaust duct Ø 200 mm. Extraction between 450-800 m³/h or 15892-28252 R³/h.
- ⊙ Steam exhaust duct, Ø 200 mm. Draught between 0.08-0.12 mbars.
- Fresh air inlet for the burner stainless steel 200 x 200 mm.

## Technical features

Models	A	B	C	D	E	F	G	H		Baking area	Floor Area	Total weight
<b>Cervap XT - 3 x 600 mm - 4 decks</b>												
600/12.205	3336	3286	6097	2860	2656	2700	2200	2301	0	14,9	8,8	5170
600/12.220	3336	3286	6486	2860	2657	2700	2200	2301	0	16	8,8	5840
600/12.242	3716	3666	6866	2860	2658	2700	2200	2301	0	17,6	9,8	6350
600/12.257	3716	3666	ND	2860	2659	2700	2200	2301	0	18,7	9,8	6600
<b>Cervap XT - 2 x 750 mm - 4 decks</b>												
750/8.205	3336	3286	6097	2528	2324	2700	2200	2301	0	12,2	7,7	5020
750/8.220	3336	3286	6486	2528	2324	2700	2200	2301	0	13,1	7,7	5200
750/8.242	3716	3666	6866	2528	2324	2700	2200	2301	0	14,4	8,6	5400
750/8.257	3716	3666	ND	2528	2324	2700	2200	2301	0	15,4	8,6	5500



# Cervap XL



## Annular steam tubes Oven Fuel/Oil - Gas

### Performances

- Baking area : from 14,8 to 18,5 m<sup>2</sup>
- Useful height on each deck : 200 mm
- Number of decks : 4
- Doors of 600
- Number of doors : 3 per deck

### The advantages

- Oven particularly designed for intensive use
- Exceptional energy yield
- High thermal mass due to increased number of tubes
- Double steam generator on each deck
- Possibility of installing a 3rd steam generator under the oven
- Annular tubes guaranteed 10 years
- Refractory stainless fire chamber guaranteed 5 years
- Deferred start-up of the oven

### Use

The Cervap XL is a deck oven designed to bake all types of breads, pastries and Danish products, it is usually used for industrial baking.

### Operating principle

A watertight tube set containing water forms the exchanger and baking chambers of this oven. The energy produced by the burner is used two times: firstly to heat the fire chamber with the flame and secondly by heating the tubes with the combustion gases. The tubes diffuse even heat in all points of the baking chamber and give your oven exceptional flexibility and reactivity.

### Construction

- **Front**
  - polished stainless steel
  - IDL door handles, 3 positions
  - removable glass doors
  - steam exhaust hood with exhaust fan
  - square edged oven bench (2 mm)
  - S/S cover between decks in 2 mm thickness
- **Baking chamber**
  - refractory concrete hearth plates 20 mm thick
  - halogen lighting
- **Heat exchanger**
  - 33 single loop annular tubes per linear meter
  - refractory stainless steel fire chamber
  - barometric damper
- **Insulation**
  - crossed rock wool panels
  - reflecting glass doors to reduce heat losses

## Annular steam tubes oven **Cervap XL**

	<b>France</b>	<b>Export</b>
<b>Burner</b>		
Gas burner	■	■
Fuel-oil burner	□	□
<b>"IDL" door handles</b>		
2 on the left, 1 on the right	■	■
<b>Controls</b>		
Electromechanical interface on the left	■	■
Opticom controls on the left	□	□
<b>Steam vent (only left)</b>		
Steam vent on each deck	■	■
<b>Steam generator</b>		
Reinforced steam generator	■	■
third steam generator under the bench	€	€
<b>Hood - Exhaust fan</b>		
Hood without exhaust fan	□	□
Hood with exhaust fan	■	■
<b>Hooks for loader - unloader</b>		
Without	■	■
With	€	€
<b>Integrated lifter</b>		
Integrated lifter	€	€
Column cover in light grey painting	■	■
Column cover in stainless steel	□	□
<b>Additional options</b>		
Adaptation for integrated lifter	□	□
Pulsed steam injection	■	■
Brass water solenoid valve	■	■
Water filter to prevent scale deposits	€	€
Fresh air inlet on burner	■	■
<b>Assembly</b>		
Built on site	■	■
<b>Electric power</b>		
~230V	■	■

<b>Technical features</b>		
<b>Models</b>	<b>Electrical protection (A)</b>	<b>Heating power Fuel-oil or Gas (kW)</b>
<b>Cervap XL - 3 x 600 mm - 4 decks</b>		
600/12.205	16A	100,0 kW
600/12.242	16A	124,0 kW
600/12.257	16A	129,0 kW

# Annular steam tubes oven **Cervap XL**

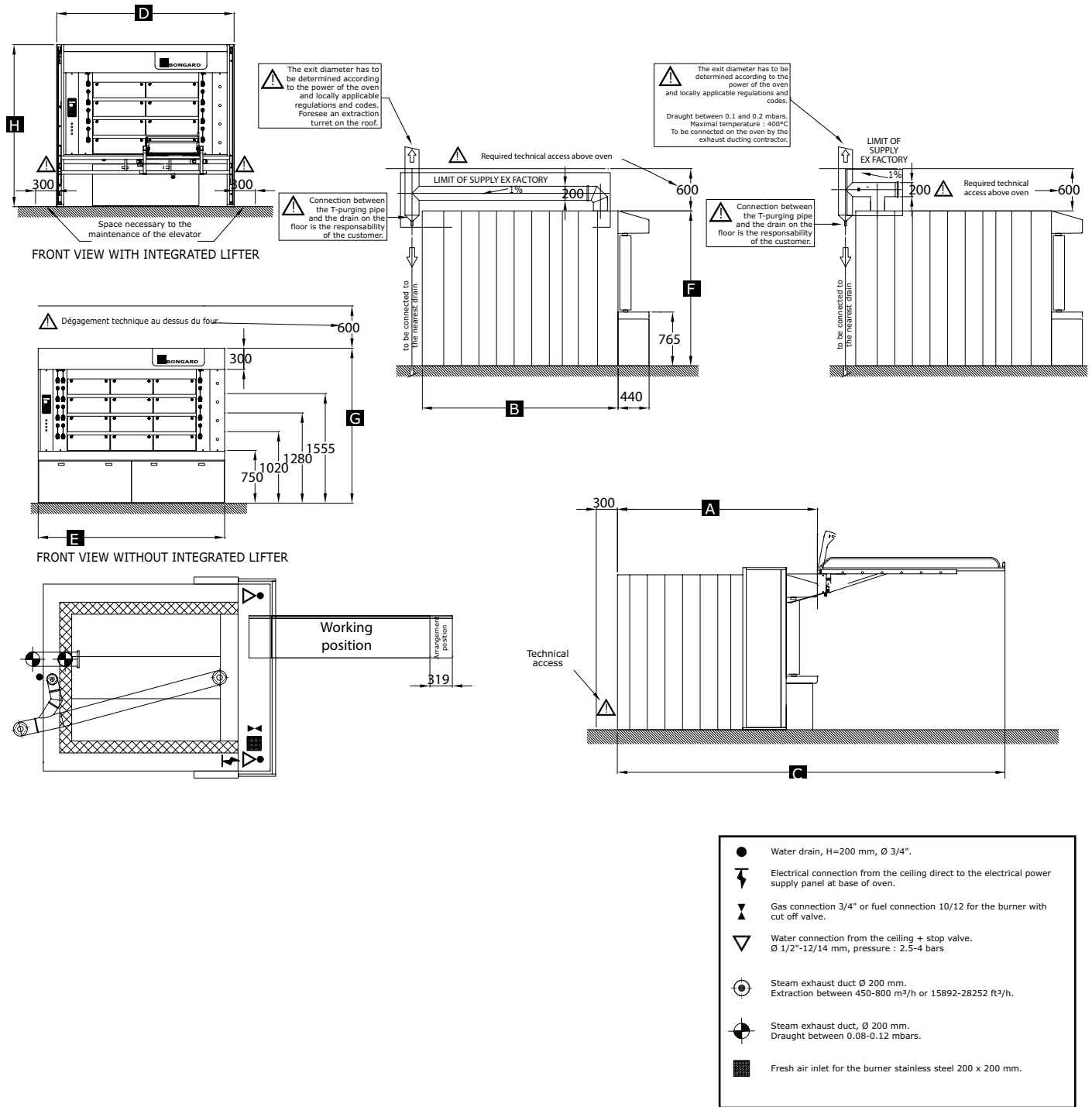

- Water drain, H=200 mm, Ø 3/4".
- ⚡ Electrical connection from the ceiling direct to the electrical power supply panel at base of oven.
- ⌘ Gas connection 3/4" or fuel connection 10/12 for the burner with cut off valve.
- ▽ Water connection from the ceiling + stop valve. Ø 1/2"-12/14 mm, pressure : 2.5-4 bars
- ⊙ Steam exhaust duct Ø 200 mm, Extraction between 450-800 m<sup>3</sup>/h or 15892-28252 ft<sup>3</sup>/h.
- ⊙ Steam exhaust duct, Ø 200 mm. Draught between 0.08-0.12 mbars.
- Fresh air inlet for the burner stainless steel 200 x 200 mm.

<b>Technical features</b>										
<b>Models</b>	<b>A</b>	<b>B</b>	<b>C</b>	<b>D</b>	<b>E</b>	<b>F</b>	<b>G</b>	<b>H</b>	<b>Baking area</b>	<b>Floor Area</b>
<b>(mm)</b>									<b>(m<sup>2</sup>)</b>	
<b>Cervap XL - 3 x 600 mm - 4 decks</b>										
600/12.205	3336	3286	6097	2860	2656	2700	2200	2301	14,9	8,8
600/12.242	3716	3666	6866	2860	2658	2700	2200	2301	17,6	9,8
600/12.257	3716	3666	ND	2860	2659	2700	2200	2301	18,7	9,8

# Cervap GME



Annular steam tubes Oven Fuel/Oil-Gas - with electric heated independant top deck

## Performances

Baking area : from 8 to 24 m<sup>2</sup>  
Useful height on each deck : 170 mm and 225 mm for the electrical top deck  
Number of decks : 4  
Doors of 600 or 750 mm  
Number of doors : 2 to 3 per deck

## The advantages

- The most compact oven in the range
- Exceptional energy yield
- Independent electrical deck
- Easy to install
- Delivered in sections for ease of assembling
- Annular tubes guaranteed 10 years
- Refractory stainless steel fire chamber guaranteed 5 years
- Deferred start-up on the oven

## Use

The Cervap GME is a deck oven designed to bake all types of breads, pastries and Danish products. Available in 2 or 3 doors, it is easily used in the bakery or in the shop. Its separate & independant electrical deck makes this oven ideal for back-up baking.

## Operating principle

A watertight tube set containing water forms the exchanger and baking chambers of this oven. The energy produced by the burner is used two times: firstly to heat the fire chamber with the flame and secondly by heating the tubes with the combustion gases. The tubes diffuse even heat in all points of the baking chamber and give your oven exceptional flexibility and reactivity.

## Construction

- **Front**
  - polished stainless steel
  - "F" door handle 3 positions
  - removable glass doors
  - steam exhaust hood with exhaust fan
- **Baking chamber**
  - sole en pierre réfractaire de 20 mm d'épaisseur
  - éclairage halogène
- **Heat exchanger**
  - 24 single loop annular tubes per linear meter
  - refractory stainless steel fire chamber
  - barometric damper
- **Steam generator**
  - independent, located inside of deck
  - 1 per deck
- **Independent electric deck**
  - independent controls for bottom and top heat
  - electrically heated steam generator
- **Insulation**
  - crossed rock wool panels
  - reflecting glass doors to reduce heat losses

# Annular steam tubes oven **Cervap GME** with electric heated independant deck

	<b>France</b>	<b>Export</b>
<b>Burner</b>		
Gas burner	■	■
Fuel-oil burner	□	□
<b>Heating elements</b>		
Access heating elements on the right	■	■
Access heating elements on the left	□	□
<b>«F» door handle</b>		
2 doors : 1 on the left - 1 on the right	■	■
<b>Controls</b>		
Electromechanical interface on the left	■	■
Opticom controls on the left (not available on model 3 decks)	□	□
<b>Steam vent (only left)</b>		
Without steam vent	■	□
Steam vent on upper deck	€	❖
Steam vent on each deck	€	■
<b>Steam generator</b>		
Reinforced steam generator on oil-gas deck	€	€
<b>Hood - Exhaust fan</b>		
Hood without exhaust fan	□	□
Hood with exhaust fan	■	■
<b>Hooks for loader - unloader</b>		
without	■	■
with	€	€
<b>Integrated lifter</b>		
Integrated lifter	€	€
Column cover in light grey painting	■	■
Column cover in stainless steel	□	□
<b>Additional options</b>		
Adaptation for integrated lifter	□	□
Dual steam push button on each deck + machinal baking timer	€	€
Brass water solenoid valve	❖	€
Pulsed steam injection	■	■
Water filter to prevent scale deposits	€	€
Fresh air inlet on burner	■	■
<b>Assembly</b>		
Built on site	■	■
<b>Electric power</b>		
<b>Technical features</b>		
<b>Models</b>	<b>Electrical protection (A)</b>	<b>Heating power Fuel-oil or Gas (kW)</b>
<b>Cervap GME - 2 x 600 mm - 4 decks</b>		
600/8.164	32	47,7
600/8.186	32	52,0
600/8.201	32	54,0
600/8.222	32	64,0
600/8.259	32	70,9
<b>Cervap GME - 2 x 750 mm - 4 decks</b>		
750/8.186	32	70,9
750/8.222	32	77,9
750/8.259	32	82,6

# Annular steam tubes oven **Cervap GME** with electric heated independant deck

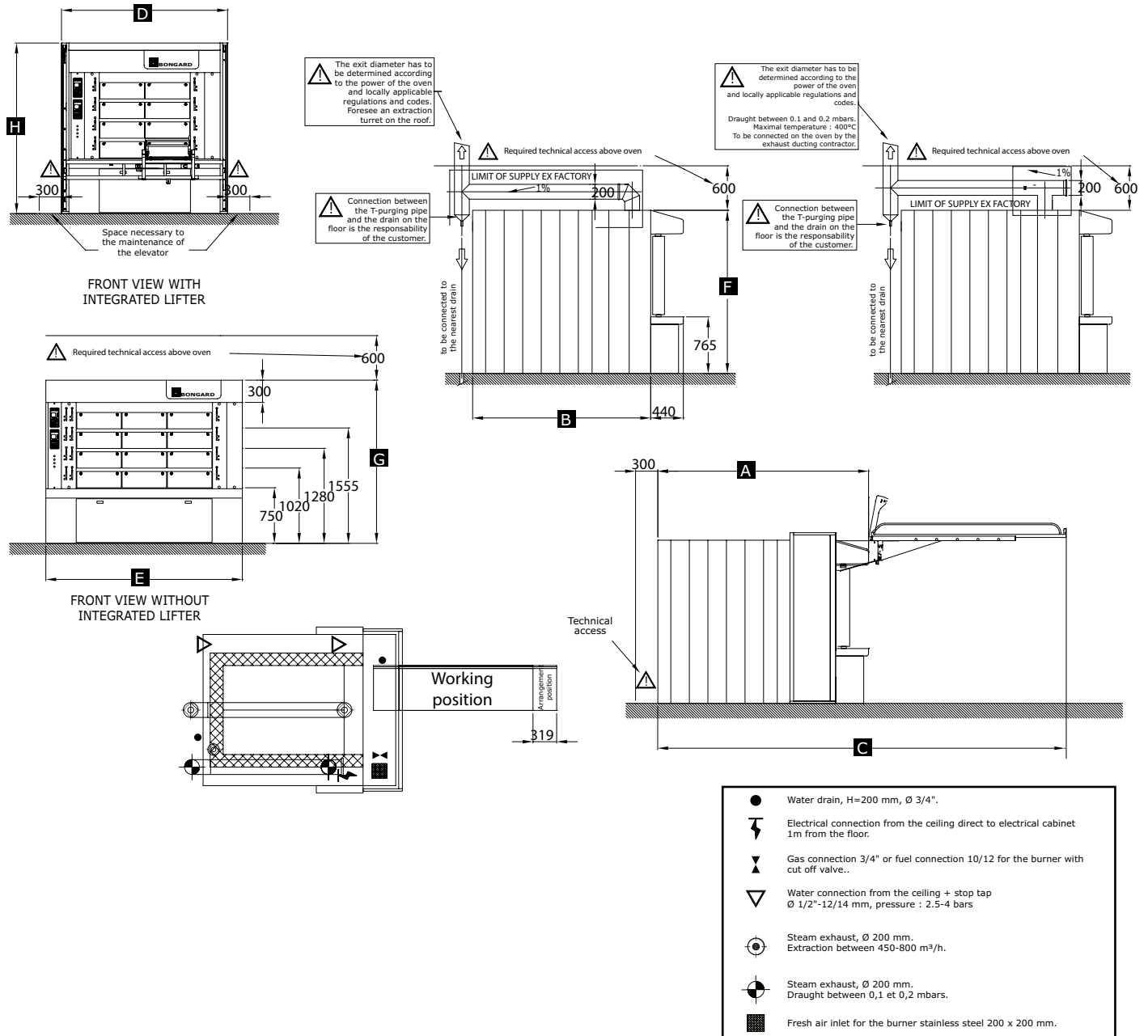

## Technical features

Models	A	B	C	D	E	F	G	H	Baking area	Floor Area	Total weight	
	(mm)											(m <sup>2</sup> )
<b>Cervap GME - 2 x 600 mm - 4 decks</b>												
600/6.164	2596	2539	4987	2242	2038	2700	2200	2301	0	7,9	5,2	3750
600/6.186	2836	2779	5597	2242	2038	2700	2200	2301	0	8,9	5,7	4000
600/6.201	2976	2919	5737	2242	2038	2700	2200	2301	0	9,6	6	4300
600/6.222	3216	3159	6366	2242	2038	2700	2200	2301	0	10,7	6,5	4500
600/6.259	3596	3539	ND	2242	2038	2700	2200	2301	0	12,6	7,3	5000
<b>Cervap GME - 2 x 750 mm - 4 decks</b>												
750/8.186	2836	2779	5597	2526	2322	2700	2200	2301	0	11	6,5	4000
750/8.222	3216	3159	6366	2526	2322	2700	2200	2301	0	13,3	7,4	5000
750/8.259	3596	3539	ND	2526	2322	2700	2200	2301	0	15,5	8,3	6000

# Orion Evo



## Deck oven - Electric

### Capacities

- Baking area: 2.8 to 22.2m<sup>2</sup>
- Number of decks: 3, 4 or 5
- Useful height of top deck: 225mm
- Useful height of ROC deck: 205mm
- Useful height of bottom deck: 180mm
- 6 baking chambers depths: 120, 160, 180, 200, 220 and 240 cm
- Available options - 1 x 800mm door, 2 x 600mm doors or 2 x 800mm doors

### The advantages

- Baking quality comparable to that of traditional ovens
- An oven for a sustained rhythm
- High baking capacities
- Flexibility of the oven to produce fresh bread at any times of the day
- Modular oven (it may be adapted from 3 to 4 decks)
- Economic
- Premium quality
- Easy to clean: sole et vitres
- Oven may be built-in on 1 side (opposite to the technical zone) and at the rear

### Utilisation

The latest addition to the Bongard range of deck ovens, Orion EVO is an electric deck oven for baking all types of bakery products - pastries and Danish pastries.

It is a high performance oven due to the quality control and consistency of the baked products, ideal for a sustainable and continuous production rate. ORION Evo 1x800mm has the option of being fitted with a upper deck in «R.O.C.» version specially designed for baking large items, over 1kg.

### Operating principle

- Equipped with its new Intuitiv 2 touch screen control panel, ORION EVO benefits from a centralised energy management system: At any time, the software will automatically allocate any available oven power to the heating elements that need it.
- The range of ORION EVO ovens is recognised for a high baking capacity which enables up to 15kg of cold dough to be baked hourly per m<sup>2</sup> of deck. A «boost baking capacity» option is also available for operations with a short baking time and/or an increased load of dough to be baked.
- The design, dimensioning and control of the steam generator are optimised in such a way as to continuously provide a good quality and generous amount of steam. Each oven deck is fitted with a water meter, guaranteeing that the correct quantity of steam is released into the baking chamber, for each baking cycle.
- The patented new design of the ORION «loading doors» provides a smooth and continuous surface between the glass and the deck, making the baking deck very easy and quick to clean.
- The windows can easily be removed by the baker. They also benefit from a special opening position for cleaning purposes.
- The baking chamber is particularly well sealed: any wasteful loss of steam during baking is greatly reduced, which also contributes towards energy savings.

### Construction

- Front
  - all in brushed stainless steel
  - new opening with patented seal
  - IDL handles 3 positions
  - removable windows with special cleaning position
  - hood with extractor
- Baking chamber
  - top and bottom deck: deck made of 20 mm thick refractory material
  - ROC deck: bottom and top made of 20 mm thick refractory material with 13 mm thick refractory hearth stones on the sides
  - interior lighting
  - high performance stainless steel heating elements, 3-year warranty
  - integrated heating element protection system on the top of baking chambers
  - decompression valve
- Steam generator
  - independent steam generator for each deck, all with water meter
  - pressure reducer
  - steam diffusion via the back of the baking chamber, «anti-splash» diffusion of water onto the bread
  - anti-limescale filter
- Insulation
  - crossed rock wool panels
  - reflective glass treatment
  - new patented loading doors sealing

### ■ Important:

The Orion Evo oven is supplied without integrated lifter, loader or hooks

# Electric deck oven **Orion EvO - 1x800**

	1x800	2x600, 2x800
<b>Technical access / Steam generator / Door handle / Control side</b>		
All on the left	■	■
All on the right	□	□
<b>Controls</b>		
Intuitiv 2 (1 control )	■	■
Ergocom (1 control per deck only for 3-4 deck ovens )	□	□
Ergocom (1 control per deck only for 5 deck ovens )	€	€
<b>Baking chamber equipment</b>		
4 th deck ROC, steam vent included, boosted baking capacity (with Intuitiv'2 only)	€	❖
Pressure reduced valve for each deck (except ROC)	■	■
Motorized steam vent for upper deck only	€	€
Motorized steam vent for each deck	€	€
Heating resistance support kit	■	■
Compatibility with a bottom mounted loader	€	€
<b>Baking capacity / energy management - with Intuitiv'2 only</b>		
Centralized energy management	■	■
Boosted baking capacity (until 18 kg/m <sup>2</sup> /H)	€	€
Intuitiv'2 optimizer	€	€
Compatibilité avec un système GTC	■	■
<b>Modularity</b>		
Evolving model (3 decks oven can be transform as a 4 decks oven)	€	€
4 deck Kit (for afterwards built-in)	€	€
<b>Steam</b>		
Pulsed steam injection	■	■
A water meter per steam generator ( for Intuitiv'2 only)	■	■
Option without water filter to prevent scale deposits	- €	- €
Water pressure reducing valve kit	■	■
<b>Accessories</b>		
Bench (except 5 decks oven)	■	■
Hood with exhaust fan and lighting	■	■
Simplified hood with exhaust fan (without grids and lightings)	- €	- €
Hooks on deck oven	€	€
Integrated lifter Lift'EvO (manual model)	€	€
Motorized integrated lifter Lift'EvO	€	■
Stainless steel loader	€	€
<b>Oven shell</b>		
Stainless steel front side and side panels in grey metallic coil coated steel	■	■
Stainless steel outside panels	€	€
<b>Assembly</b>		
Built on site	■	■
12 mm oven base	€	€
Assembled on a 12 mm base	ask us	ask us
<b>Voltage</b>		
4N ~ 380-400V	■	■
3 ~ 200-208V (for 4-5 decks , depth 120 ,160 & 200cm , not available with boosted capacity)	€	€

ask us for other voltage



# Electric deck oven **Orion EvO - 1x800**

<b>Technical features</b>							
Model	<b>With Intuitiv'2</b>				<b>With Ergocom</b>		
	Standard baking capacity		Upgraded baking capacity		Standard baking capacity		
	Electrical power	Electrical protection	Electrical power	Electrical protection	Electrical power	Electrical protection	
	(kW)	(A)	(kW)	(A)	(kW)	(A)	
<b>Orion EVO- 1 x 800 mm - 3 decks</b>							
801/3.120	19,3	40	23,4	63	19,3	40	
801/3.160	23,1	63	28,4	63	23,1	63	
801/3.180	24,9	63	33,7	63	24,9	63	
801/3.200	26,8	63	36,2	80	26,8	63	
801/3.220	31,6	63	38,7	80	31,6	63	
801/3.240	33,4	63	41,2	80	33,4	63	
<b>Orion EVO- 1 x 800 mm - 4 decks</b>							
801/4.120	25,3	63	29,3	63	25,3	63	
801/4.160	30,3	63	35,6	80	30,3	63	
801/4.180	32,8	80	42,6	80	32,8	80	
801/4.200	35,3	80	45,7	100	35,3	80	
801/4.220	41,6	80	48,8	100	41,6	80	
801/4.240	44,1	100	51,9	100	44,1	100	
<b>Orion EVO - 1 x 800 mm - 5 decks</b>							
801/5.120	31,3	63	35,3	80	31,3	63	
801/5.160	37,5	80	42,8	80	37,5	80	
801/5.180	40,6	80	51,4	100	40,6	80	
801/5.200	43,8	100	55,1	125	43,8	100	
801/5.220	51,7	100	58,9	125	51,7	100	
801/5.240	54,8	125	62,6	125	54,8	125	

# Electric deck oven Orion EvO - 1x800

STEAM

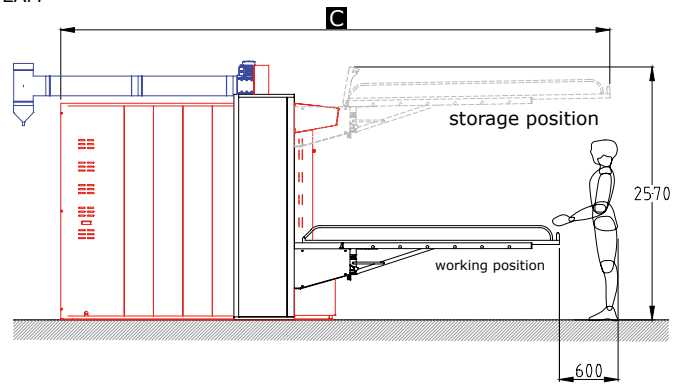
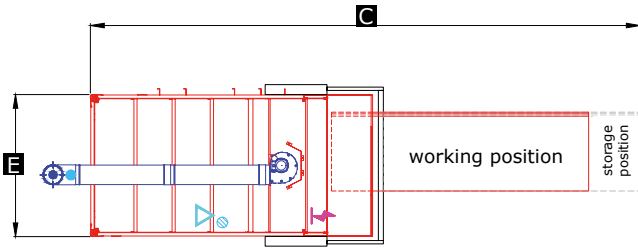

With integrated lifter

With integrated lifter

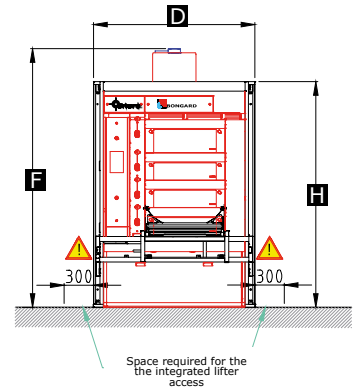
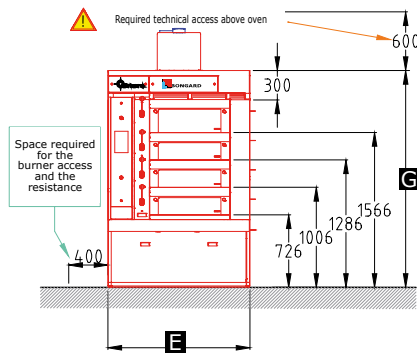
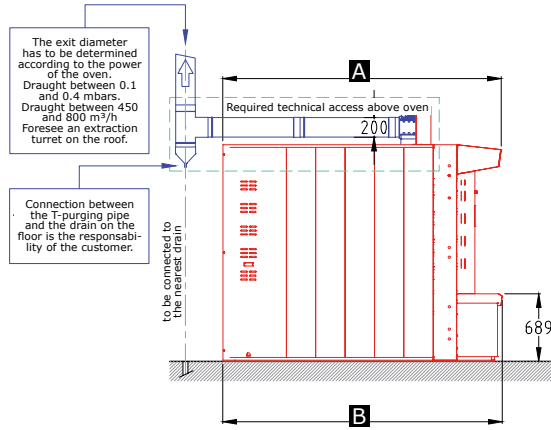

Without integrated lifter

Without integrated lifter

With integrated lifter

## Dimensions

Models	Overall depth	Depth (floor)	Depth (oven + loader)	Width with lifter	Oven width	Overall height	Oven height (front)	Front height with lifter (without loader + hook)	Baking area	Floor area	Net weight without base without option
	A	B	C	D	E	F	G	H			
(mm)											
Orion EvO - 1 x 800 mm - 3 decks											
801/3.120	2252	2204	4268	1645	1441	2682	2200	2301	2,8	3,2	1227
801/3.160	2666	2618	5052	1645	1441	2682	2200	2301	3,8	3,8	1419
801/3.180	2878	2830	5634	1645	1441	2682	2200	2301	4,3	4,1	1540
801/3.200	3072	3024	5828	1645	1441	2682	2200	2301	4,8	4,4	1621
801/3.220	3282	3234	6427	1645	1441	2682	2200	2301	5,3	4,7	1707
801/3.240	3477	3429	6622	1645	1441	2682	2200	2301	5,8	5,0	1812
Orion EvO - 1 x 800 mm - 4 decks											
801/4.120	2252	2204	4268	1645	1441	2682	2200	2301	3,8	3,2	1425
801/4.160	2666	2618	5052	1645	1441	2682	2200	2301	5,1	3,8	1676
801/4.180	2878	2830	5634	1645	1441	2682	2200	2301	5,8	4,1	1797
801/4.200	3072	3024	5828	1645	1441	2682	2200	2301	6,4	4,4	1895
801/4.220	3282	3234	6427	1645	1441	2682	2200	2301	7,1	4,7	2022
801/4.240	3477	3429	6622	1645	1441	2682	2200	2301	7,7	5,0	2145
Orion EvO - 1 x 800 mm - 5 decks											
801/5.120	2242	1812	4268	1645	1441	2682	2200	2301	4,8	2,6	1623
801/5.160	2656	2226	5052	1645	1441	2682	2200	2301	6,4	3,2	1914
801/5.180	2868	2438	5634	1645	1441	2682	2200	2301	7,3	3,5	2073
801/5.200	3062	2632	5828	1645	1441	2682	2200	2301	8,1	3,8	2188
801/5.220	3272	2842	6427	1645	1441	2682	2200	2301	8,9	4,1	2334
801/5.240	3467	3037	6622	1645	1441	2682	2200	2301	9,7	4,4	2459

# Electric deck oven **Orion EvO - 2x600**

<b>Technical features</b>						
Model	<b>With Intuitiv'2</b>				<b>With Ergocom</b>	
	Standard baking capacity		Upgraded baking capacity		Standard baking capacity	
	Electrical power	Electrical protection	Electrical power	Electrical protection	Electrical power	Electrical protection
	(kW)	(A)	(kW)	(A)	(kW)	(A)
<b>Orion EVO- 2 x 600 mm- 3 decks</b>						
602/3.120	25,4	63	34,3	80	25,4	63
602/3.160	33,9	80	41,8	80	33,9	80
602/3.180	36,7	80	49,9	100	36,7	80
602/3.200	39,5	80	53,7	100	39,5	80
602/3.220	46,7	100	57,4	125	46,7	100
602/3.240	49,5	100	61,2	125	49,5	100
<b>Orion EVO- 2 x 600 mm - 4 decks</b>						
602/4.120	33,4	80	43,3	100	33,4	80
602/4.160	44,7	100	52,7	100	44,7	100
602/4.180	48,5	100	63,1	125	48,5	100
602/4.200	52,2	125	67,8	160	52,2	125
602/4.220	61,8	125	72,5	160	61,8	125
602/4.240	65,5	125	77,2	160	65,5	125
<b>Orion EVO- 2 x 600 mm - 5 decks</b>						
602/5.120	41,4	80	52,2	100	41,4	80
602/5.160	55,6	125	63,5	125	55,6	125
602/5.180	60,2	125	76,4	160	60,2	125
602/5.200	64,9	125	82,0	160	64,9	125
602/5.220	76,9	160	87,6	160	76,9	160
602/5.240	81,5	160	93,2	160	81,5	160

# Electric deck oven Orion EvO - 2x600

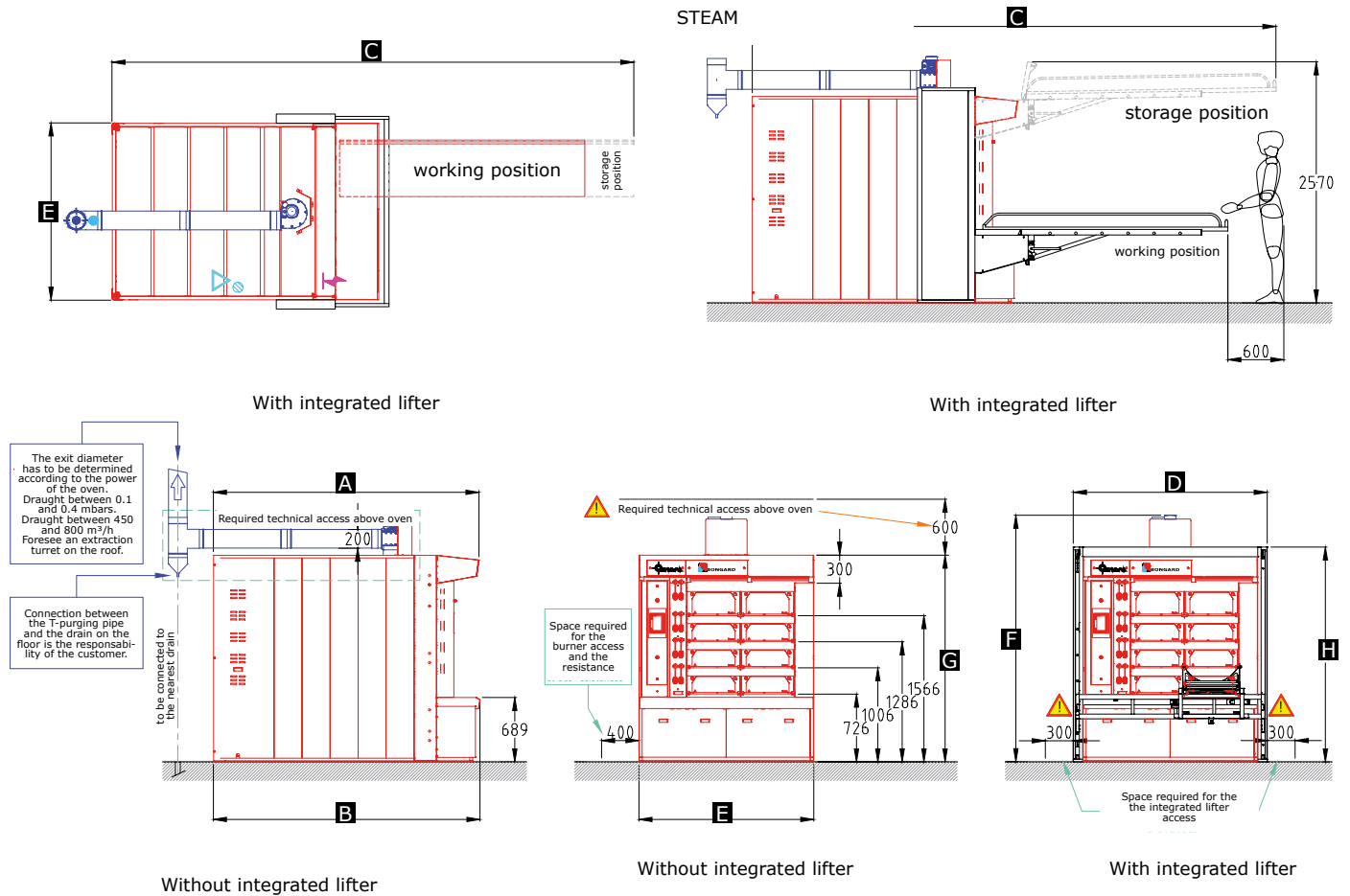

Models	Dimensions (mm)								Baking area (m <sup>2</sup> )		Net weight without base without option
	Overall depth (A)	Depth (floor) (B)	Depth (oven + loader) (C)	Width with lifter (D)	Oven width (E)	Overall height (F)	Oven height (front) (G)	Front height with lifter (without loader + hook) (H)	Floor area	Baking area	
<b>Orion EvO - 2 x 600 mm - 3 decks</b>											
602/3.120	2252	2204	4268	2093	1889	2682	2200	2301	4,4	4,2	1525
602/3.160	2666	2618	5052	2093	1889	2682	2200	2301	5,9	4,9	1776
602/3.180	2878	2830	5634	2093	1889	2682	2200	2301	6,7	5,3	1934
602/3.200	3072	3024	5828	2093	1889	2682	2200	2301	7,4	5,7	2081
602/3.220	3282	3234	6427	2093	1889	2682	2200	2301	8,1	6,1	2179
602/3.240	3477	3429	6622	2093	1889	2682	2200	2301	8,9	6,5	2290
<b>Orion EvO - 2 x 600 mm - 4 decks</b>											
602/4.120	2252	2204	4268	2093	1889	2682	2200	2301	5,8	4,2	1790
602/4.160	2666	2618	5052	2093	1889	2682	2200	2301	7,9	4,9	2138
602/4.180	2878	2830	5634	2093	1889	2682	2200	2301	8,9	5,3	2308
602/4.200	3072	3024	5828	2093	1889	2682	2200	2301	9,8	5,7	2468
602/4.220	3282	3234	6427	2093	1889	2682	2200	2301	10,9	6,1	2609
602/4.240	3477	3429	6622	2093	1889	2682	2200	2301	11,8	6,5	2764
<b>Orion EvO - 2 x 600 mm - 5 decks</b>											
602/5.120	2242	1812	4268	2093	1889	2682	2200	2301	7,3	3,4	2092
602/5.160	2656	2226	5052	2093	1889	2682	2200	2301	9,8	4,2	2463
602/5.180	2868	2438	5634	2093	1889	2682	2200	2301	11,1	4,6	2701
602/5.200	3062	2632	5828	2093	1889	2682	2200	2301	12,3	5,0	2892
602/5.220	3272	2842	6427	2093	1889	2682	2200	2301	13,6	5,4	3057
602/5.240	3467	3037	6622	2093	1889	2682	2200	2301	14,8	5,7	3238

# Electric deck oven **Orion EvO - 2x800**

<b>Technical features</b>						
Model	<b>With Intuitiv'2</b>				<b>With Ergocom</b>	
	Standard baking capacity		Upgraded baking capacity		Standard baking capacity	
	Electrical power	Electrical protection	Electrical power	Electrical protection	Electrical power	Electrical protection
	(kW)	(A)	(kW)	(A)	(kW)	(A)
<b>Orion EVO- 2 x 800 mm- 3 decks</b>						
802/3.120	34,3	80	42,4	80	34,3	80
802/3.160	41,8	80	56,7	125	41,8	80
802/3.180	49,9	100	61,7	125	49,9	100
802/3.200	53,7	125	66,7	125	53,7	125
802/3.220	57,4	125	71,7	160	57,4	125
802/3.240	61,2	125	76,7	160	61,2	125
<b>Orion EVO- 2 x 800 mm - 4 decks</b>						
802/4.120	45,3	100	53,4	125	45,3	100
802/4.160	55,3	125	71,7	160	55,3	125
802/4.180	66,1	125	77,9	160	66,1	125
802/4.200	71,1	160	84,2	160	71,1	160
802/4.220	76,1	160	90,4	200	76,1	160
802/4.240	81,1	160	96,7	200	81,1	160
<b>Orion EVO- 2 x 800 mm - 5 decks</b>						
802/5.120	56,3	125	64,4	125	56,3	125
802/5.160	68,8	160	86,6	160	68,8	160
802/5.180	82,3	160	94,1	200	82,3	160
802/5.200	88,5	200	101,6	200	88,5	200
802/5.220	94,8	200	109,1	200	94,8	200
802/5.240	101	200	116,6	200	101	200

# Electric deck oven Orion EvO - 2x800

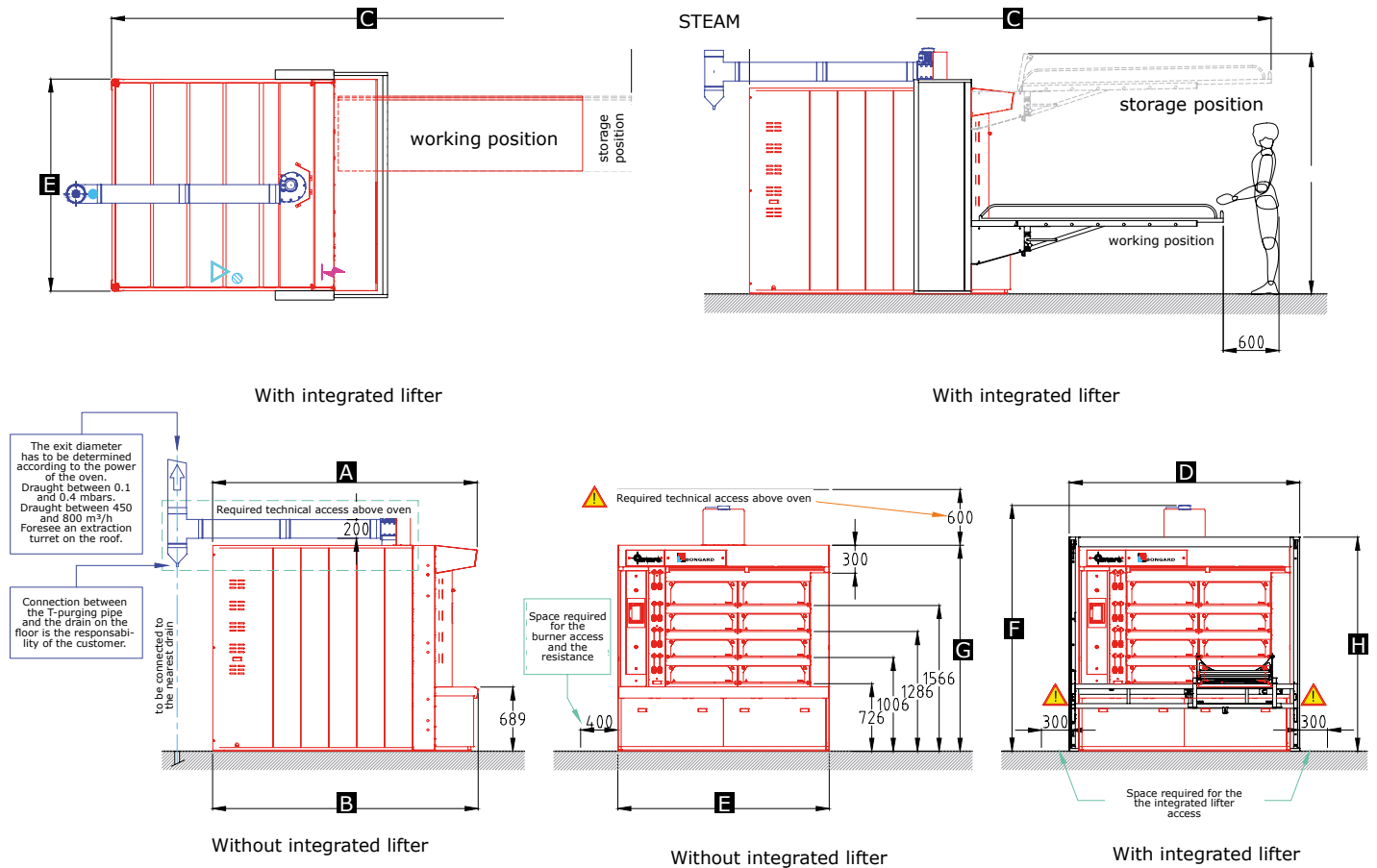

<b>Dimensions</b>											
	Overall depth	Depth (floor)	Depth (oven + loader)	Width with lifter	Oven width	Overall height	Oven height (front)	Front height with lifter (without loader + hook)	Baking area	Floor area	Net weight without base without option
Models	A	B	C	D	E	F	G	H			
(mm)											
(m <sup>2</sup> )											
<b>Orion EvO - 2 x 800 mm - 3 decks</b>											
802/3.120	2252	2204	4268	2549	2345	2682	2200	2301	5,7	5,2	1811
802/3.160	2666	2618	5052	2549	2345	2682	2200	2301	7,7	6,1	2125
802/3.180	2878	2830	5634	2549	2345	2682	2200	2301	8,7	6,6	2314
802/3.200	3072	3024	5828	2549	2345	2682	2200	2301	9,7	7,1	2474
802/3.220	3282	3234	6427	2549	2345	2682	2200	2301	10,7	7,6	2612
802/3.240	3477	3429	6622	2549	2345	2682	2200	2301	11,6	8,0	2777
<b>Orion EvO - 2 x 800 mm - 4 decks</b>											
802/4.120	2252	2204	4268	2549	2345	2682	2200	2301	7,7	5,2	2143
802/4.160	2666	2618	5052	2549	2345	2682	2200	2301	10,3	6,1	2555
802/4.180	2878	2830	5634	2549	2345	2682	2200	2301	11,7	6,6	2765
802/4.200	3072	3024	5828	2549	2345	2682	2200	2301	12,9	7,1	2965
802/4.220	3282	3234	6427	2549	2345	2682	2200	2301	14,3	7,6	3177
802/4.240	3477	3429	6622	2549	2345	2682	2200	2301	15,5	8,0	3360
<b>Orion EvO - 2 x 800 mm - 5 decks</b>											
802/5.120	2242	1812	4268	2549	2345	2682	2200	2301	9,6	4,2	2496
802/5.160	2656	2226	5052	2549	2345	2682	2200	2301	12,9	5,2	2984
802/5.180	2868	2438	5634	2549	2345	2682	2200	2301	14,6	5,7	3216
802/5.200	3062	2632	5828	2549	2345	2682	2200	2301	16,2	6,2	3473
802/5.220	3272	2842	6427	2549	2345	2682	2200	2301	17,9	6,7	3723
802/5.240	3467	3037	6622	2549	2345	2682	2200	2301	19,4	7,1	3961

# Lift'EvO manual



## Integrated lifter for deck ovens

### Performances

- Available on all the range of deck ovens bongard
- Maximum loading weight : 25 kg

### The advantages

- Safe environment: new braking and loader repositioning system
- Robust and reliable
- Easy and rapid assembly
- May be stored in the high position
- Narrow fixing columns
- Safety audited by an independent agency
- Working comfort: new damping device
- Allows the loading of 25 kg dough within one movement

### Use

The integrated lifter Lift'EvO allows loading and unloading of baking chambers, while reducing the baker's lifting effort.

### Operating principle

- Two columns, on both sides of the trim, support the integrated lifter. Lift'EvO's lifting movement is assisted by a gear motor that acts simultaneously on both columns to ensure a horizontal position at all times.
- The lift stops precisely at the stop corresponding to the level to be loaded.
- Once the loader is positioned in front of the track, the conveyor is manually operated to carry out loading and unloading.
- Lift'EvO is equipped with a high-performance braking system that stops immediately the conveyor at the end of the movement.
- Lift'EvO has an additional stop position, intermediate between two levels, which can be adjusted by the user during installation to the working height desired.

### Construction

- Steel structure and durable powder paint
- New braking system

#### Important note:

When hooks for loader-unloader are fitted on lifter, the oven must be ordered without hooks.

The control reversibility (right/left door handle) can not be done during assembling. Be sure that the ceiling is tall enough to ensure the storage of the lifter in high position, in front of the hood.

# Integrated lifter Lift'EvO (manual model) for Orion EvO

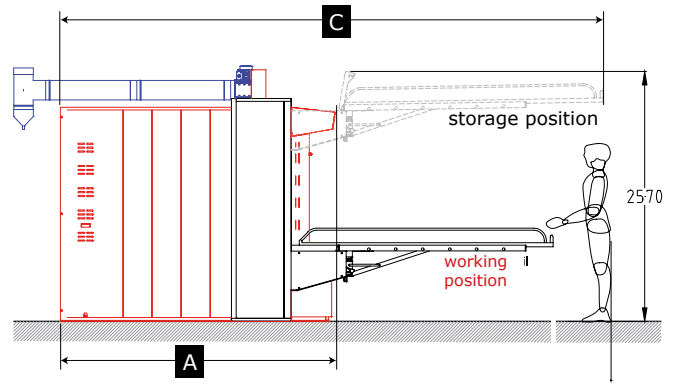
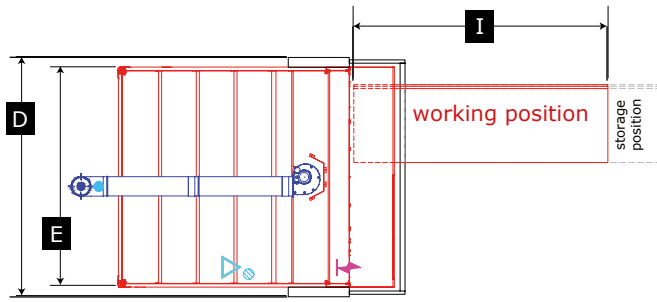

● ● ● **Important notes :**  
 Total height in storage position > 1880 mm  
 Narrow fixing columns : 2 x 10 cm width.

## ■ ORION EvO 1x800

Depth	A	I	C	E	D	Overall width (+mini. Technical access)
	Overall depth	Length (lifter)	Depth (oven+lifter in storage position)	Width (oven)	Width (oven+lifter)	
(mm)						
<b>Mobile hooks on lifter</b>						
120	2226	1886	4242	1441	1645	2245
160	2640	2256	5026	1441	1645	2245
180	2852	2626	5608	1441	1645	2245
200	3046	2626	5802	1441	1645	2245
220	3256	3015	6401	1441	1645	2245
240	3451	3015	6596	1441	1645	2245
<b>Fixed hooks on lifter</b>						
120	2226	2256	4612	1441	1645	2245
160	2640	2626	5396	1441	1645	2245
180	2852	3015	5997	1441	1645	2245
200	3046	3015	6191	1441	1645	2245
220	3256	-	-	1441	1645	2245
240	3451	-	-	1441	1645	2245
<b>Fixed hooks on oven</b>						
120	2226	1886	4242	1441	1645	2245
160	2640	2256	5026	1441	1645	2245
180	2852	2256	5238	1441	1645	2245
200	3046	2626	5802	1441	1645	2245
220	3256	3015	6401	1441	1645	2245
240	3451	3015	6596	1441	1645	2245



## Integrated lifter Lift'EvO (manual model) for Orion EvO

### ■ Orion EvO 2x600

Depth	A	I	C	E	D	Overall width (+mini. Technical access)
	Overall depth	Length (lifter)	Depth (oven+lifter in storage position)	Width (oven)	Width (oven+lifter)	
(mm)						
<b>Mobile hooks on lifter</b>						
120	2226	1886	4242	1889	2093	2693
160	2640	2256	5026	1889	2093	2693
180	2852	2626	5608	1889	2093	2693
200	3046	2626	5802	1889	2093	2693
220	3256	3015	6401	1889	2093	2693
240	3451	3015	6596	1889	2093	2693
<b>Fixed hooks on lifter</b>						
120	2226	2256	4612	1889	2093	2693
160	2640	2626	5396	1889	2093	2693
180	2852	3015	5997	1889	2093	2693
200	3046	3015	6191	1889	2093	2693
220	3256	-	-	1889	2093	2693
240	3451	-	-	1889	2093	2693
<b>Fixed hooks on oven</b>						
120	2226	1886	4242	1889	2093	2693
160	2640	2256	5026	1889	2093	2693
180	2852	2256	5238	1889	2093	2693
200	3046	2626	5802	1889	2093	2693
220	3256	3015	6401	1889	2093	2693
240	3451	3015	6596	1889	2093	2693

### ■ Orion EvO 2x800

Depth	A	I	C	E	D	Overall width (+mini. Technical access)
	Overall depth	Length (lifter)	Depth (oven+lifter in storage position)	Width (oven)	Width (oven+lifter)	
(mm)						
<b>Mobile hooks on lifter</b>						
120	2226	1886	4242	2345	2549	3149
160	2640	2256	5026	2345	2549	3149
180	2852	2626	5608	2345	2549	3149
200	3046	2626	5802	2345	2549	3149
220	3256	3015	6401	2345	2549	3149
240	3451	3015	6596	2345	2549	3149
<b>Fixed hooks on lifter</b>						
120	2226	2256	4612	2345	2549	3149
160	2640	2626	5396	2345	2549	3149
180	2852	3015	5997	2345	2549	3149
200	3046	3015	6191	2345	2549	3149
220	3256	-	-	2345	2549	3149
240	3451	-	-	2345	2549	3149
<b>Fixed hooks on oven</b>						
120	2226	1886	4242	2345	2549	3149
160	2640	2256	5026	2345	2549	3149
180	2852	2256	5238	2345	2549	3149
200	3046	2626	5802	2345	2549	3149
220	3256	3015	6401	2345	2549	3149
240	3451	3015	6596	2345	2549	3149

# Integrated lifter Lift'EvO (manual model) for Cervap Compact/Compact GME/RS

## ■ CERVAP COMPACT / COMPACT GME

	A	I	C	E	D	
Depth	Overall depth	Length (lifter)	Depth (oven+lifter in storage position)	Width (oven)	Width (oven+lifter)	Overall width (+mini. Technical access)
(mm)						
<b>Mobile hooks on lifter</b>						
123	2240	1886	4243	1340	1544	2144
143	2450	2256	4823	1340	1544	2144
<b>Fixed hooks on lifter</b>						
123	2240	2256	4613	1340	1544	2144
143	2450	2626	5193	1340	1544	2144
<b>Fixed hooks on oven</b>						
123	2240	1886	4243	1340	1544	2144
143	2450	1886	4453	1340	1544	2144

## ■ CERVAP RS

	A	I	C	E	D	
Depth	Overall depth	Length (lifter)	Depth (oven+lifter in storage position)	Width (oven)	Width (oven+lifter)	Overall width (+mini. Technical access)
(mm)						
1x800				1250	1454	2054
1x1200				1660	1864	2464
<b>Mobile hooks on lifter</b>						
160	2726	-	-			
200	3087	-	-			
<b>Fixed hooks on lifter</b>						
160	2726	2626	5422			
200	3087	3015	6172			
<b>Fixed hooks on oven</b>						
160	2726	-	-			
200	3087	-	-			

# Integrated lifter Lift'EvO (manual model) for Cervap 600-750

## ■ CERVAP 600 - 750

	A	I	C	E	D	
Depth	Overall depth	Length (lifter)	Depth (oven+lifter in storage position)	Width (oven)	Width (oven+lifter)	Overall width (+mini. Technical access)
(mm)						
1x750				1564	1768	2368
2x600				2038	2242	2842
2x750				2322	2526	3126
3x600				2654	2858	3458
<b>Mobile hooks on lifter</b>						
149	2456	2256	4862			
164	2596	2256	5002			
186	2836	2626	5612			
201	2976	2626	5752			
222	3216	3015	6381			
259	3596	-	-			
<b>Fixed hooks on lifter</b>						
149	2456	2626	5232			
164	2596	2626	5372			
186	2836	3015	6001			
201	2976	3015	6141			
222	3216	-	-			
259	3596	-	-			
<b>Fixed hooks on oven</b>						
149	2456	1886	4492			
164	2596	2256	5002			
186	2836	2256	5242			
201	2976	2626	5752			
222	3216	2626	5992			
259	3596	3015	6761			

# Integrated lifter Lift'EvO (manual model) for Cervap DT-XT-XL

## ■ CERVAP DT

Depth	A	I	C	E	D	Overall width (+mini. Technical access)
	Overall depth	Length (lifter)	Depth (oven+lifter in storage position)	Width (oven)	Width (oven+lifter)	
(mm)						
2x600				2038	2242	2842
2x750				2322	2526	3126
<b>Mobile hooks on lifter</b>						
169	2946	2256	5352			
184	3086	2626	5862			
205	3326	2626	6102			
242	3706	3015	6871			
<b>Fixed hooks on lifter</b>						
169	2946	2626	5722			
184	3086	3015	6251			
205	3326	3015	6491			
242	3706	-	-			
<b>Fixed hooks on oven</b>						
169	2946	2256	5352			
184	3086	2256	5492			
205	3326	2626	6102			
242	3706	3015	6871			

## ■ CERVAP XT - XL

Depth	A	I	C	E	D	Overall width (+mini. Technical access)
	Overall depth	Length (lifter)	Depth (oven+lifter in storage position)	Width (oven)	Width (oven+lifter)	
(mm)						
3x600				2656	2860	3460
2x750				2324	2528	3128
<b>Mobile hooks on lifter</b>						
184	2846	2626	5622			
205	3336	2626	6112			
220	3336	3015	6501			
242	3716	3015	6881			
257	3716	-	-			
<b>Fixed hooks on lifter</b>						
184	2846	3015	6011			
205	3336	3015	6501			
220	3336	ND	#VALUE			
242	3716	-	-			
257	3716	-	-			
<b>Fixed hooks on oven</b>						
184	2846	2256	5252			
205	3336	2626	6112			
220	3336	2626	6112			
242	3716	3015	6881			
257	3716	3015	6881			

# Lift'EvO motorized



Only available  
on  
Orion EvO  
1 x 800

## Suitable for Orion EvO 1x800 deck ovens

### Performances

The lifter can be integrated to the whole range of Bongard deck ovens, 1, 2, or 3 doors wide.

### The advantages

- Saves workspace around the oven
- Compact
- Easy to use
- Easy to store

### Use

The integrated lifter is used to load and unload baking chambers.

### Operating principle

Two columns located on either side of the oven frame support the integrated lifter. An ergonomic handle is used to raise or lower the lift. Once the loader is positioned in front of the oven door, the loader is activated for loading and unloading.

- Elevator is stored in front of the oven, at hood level. Attention : make sure there is enough clearance under ceiling.
- Ergonomic handles : for lifting and loading
- Handles can be assembled, on site, either on the right or on the left
- Height under lifter on highest position : 1880 mm
- Reduced size of lifter columns : 2x10 cm wide
- Tilting hook system on lifter as standard supply

### Construction

- Waterproof bearings, no maintenance for the sliding motion of the loader - unloader
- Translation parts in stainless steel and plastic materials
- Lifting system with chains and counterweight

### • • • Important note:

When hooks for loader-unloader are fitted on lifter, the oven must be ordered without hooks

# Motorized Integrated lifter Lift'EvO - Orion EvO 1x800

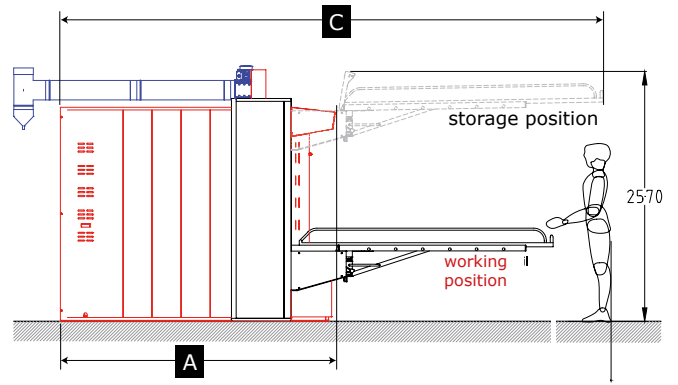
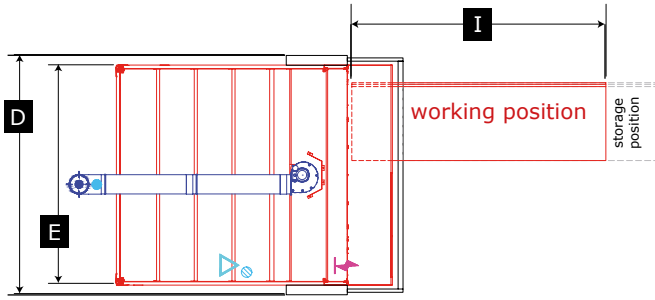

● ● ● **Important notes :**  
 Total height in storage position > 1880 mm  
 Narrow fixing columns : 2 x 10 cm width.

	A	I	E	D	
Depth	Overall depth	Length (lifter)	Width (oven)	Width (oven+lifter)	Overall width (+mini. Technical access)
(mm)					
<b>Mobile hooks on lifter</b>					
120	2226	1886	1441	1645	2245
160	2640	2256	1441	1645	2245
180	2852	2626	1441	1645	2245
200	3046	2626	1441	1645	2245
220	3256	3015	1441	1645	2245
240	3451	3015	1441	1645	2245
<b>Fixed hooks on lifter</b>					
120	2226	2256	1441	1645	2245
160	2640	2626	1441	1645	2245
180	2852	3015	1441	1645	2245
200	3046	3015	1441	1645	2245
220	3256	ND	1441	1645	2245
240	3451	ND	1441	1645	2245
<b>Fixed hooks on oven</b>					
120	2226	1886	1441	1645	2245
160	2640	2256	1441	1645	2245
180	2852	2256	1441	1645	2245
200	3046	2626	1441	1645	2245
220	3256	3015	1441	1645	2245
240	3451	3015	1441	1645	2245

# Scissors type lifting



Not compatible with Cervap Compact and Cervap Compact GME

Suitable for Cervap and Oméga2 type deck ovens

## Use

Designed for Cervap and Oméga2 ovens, in door width of 600, 750 and 800 mm, up to 4 decks

## Operating principle

The scissor lift does not come with "hooks" to lock the rod of the loader belt. Lifting and lowering assisted by compensating springs (manual lift version).

## Construction

- Epoxy painted structure
- Epoxy coated (food grade)

## • • • Important notes :

Oven needs to have Hooks for Scissors type loader base top be compatible. Supplied without loader.

## The advantages

- Compact
- Easy to use
- Easy to tidy

Standard lifter

Manual lifter, handle on the left

Motorized lifter

Motorized lifter, control on the left

# Loader unloader

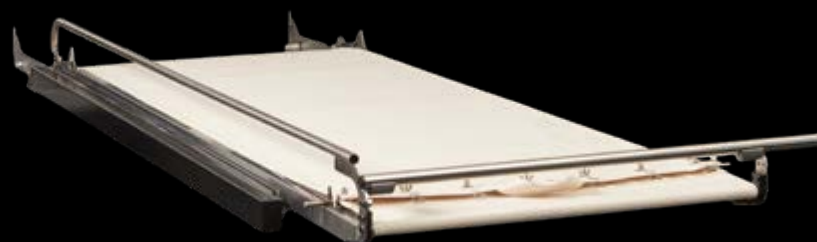

for deck ovens Cervap and Orion EVO

## **Use**

Designed only for the Cervap and Orion EVO.

## **Operating principle**

Acts only as hand-held "loading system".  
Loader-unloader supplied with belt.

## **Construction**

Stainless steel & aluminium structure

## **Option**

Tiltable ramp

## **The advantages**

- For quick loading and unloading, in complete safety
- Compact
- Easy to use
- Easy to store



## Deck ovens **Loader-Unloader**

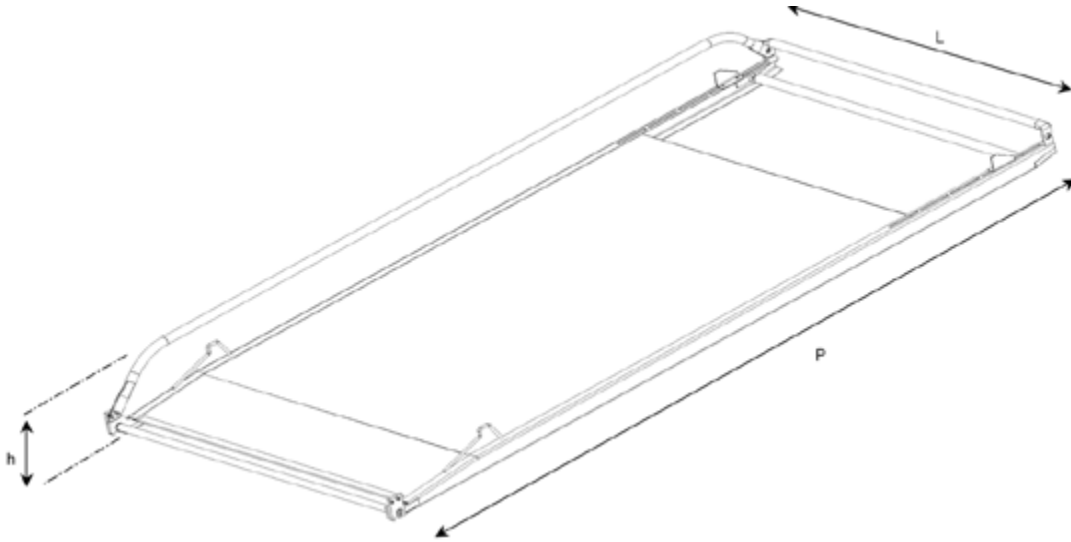

<b>P</b> <b>(mm)</b>	<b>L</b> <b>(mm)</b>	<b>H</b> <b>(mm)</b>
<b>Loader-unloader, door width of 600 mm with belt</b>		
1886	600	167
2256	600	167
2626	600	167
3015	600	167
<b>Loader-unloader, door width of 750 mm with belt</b>		
1886	742	167
2256	742	167
2626	742	167
3015	742	167
<b>Loader-unloader, door width of 800 mm with belt</b>		
1886	790	147
1886	790	167
2256	790	167
2626	790	167
3015	790	167
2256	790	147
2626	790	147
3015	790	147
<b>Belt with rod, door width of 600 mm</b>		
1886	600	
2256	600	
2626	600	
3015	600	
<b>Belt with rod, door width of 750 mm</b>		
1886	742	
2256	742	
2626	742	
3015	742	
<b>Belt with rod, door width of 800 mm</b>		
1886	790	
2256	790	
2626	790	
3015	790	

# Stainless steel loader-unloader

## Doors width of 600 mm

### Selection table of loader-unloader kit with belt , according to type of lifter and hooks

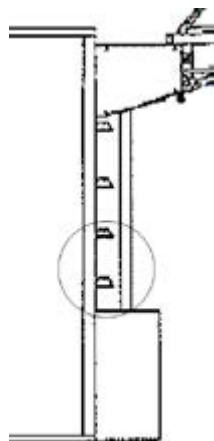
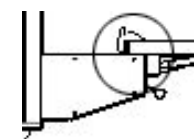
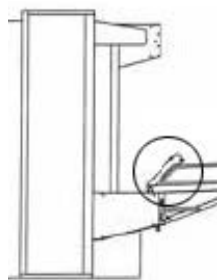

#### Stainless steel loader-unloader for 600mm door width ovens

##### Depth of loader-unloader

1886 mm    2256 mm    2626 mm    3015 mm

	1886 mm	2256 mm	2626 mm	3015 mm
<b>Loader-unloader for standard integrated lifter with tilting hooks</b>				
Cervap - Cervap GME 164	❖	€	❖	❖
Cervap - Cervap GME 186	❖	❖	€	❖
Cervap - Cervap GME 201	❖	❖	€	❖
Cervap - Cervap GME 222	❖	❖	❖	€
Cervap DT 184	❖	❖	€	❖
Cervap DT 205	❖	❖	€	❖
Cervap DT 242	❖	❖	❖	€
Cervap XT 205	❖	❖	€	❖
Cervap XT 220	❖	❖	❖	€
Cervap XT 242	❖	❖	❖	€
Orion EvO 120	€	❖	❖	❖
Orion EvO 160	❖	€	❖	❖
Orion EvO 180	❖	❖	€	❖
Orion EvO 200	❖	❖	€	❖
Orion EvO 220	❖	❖	❖	€
Orion EvO 240	❖	❖	❖	€
<b>Loader-unloader for standard integrated lifter with fixed hooks</b>				
Cervap RS 1200/5.160	❖	❖	€	❖
Cervap RS 1200/5.200	❖	❖	❖	€
Cervap - Cervap GME 164	❖	❖	€	❖
Cervap - Cervap GME 186	❖	❖	❖	€
Cervap - Cervap GME 201	❖	❖	❖	€
Cervap DT 184	❖	❖	❖	€
Cervap DT 205	❖	❖	❖	€
Cervap XT 205	❖	❖	❖	€
Orion EvO 120	❖	€	❖	❖
Orion EvO 160	❖	❖	€	❖
Orion EvO 180	❖	❖	❖	€
Orion EvO 200	❖	❖	❖	€
<b>Loader-unloader for standard integrated lifter without hooks</b>				
Cervap - Cervap GME 164	❖	€	❖	❖
Cervap - Cervap GME 186	❖	€	❖	❖
Cervap - Cervap GME 201	❖	❖	€	❖
Cervap - Cervap GME 222	❖	❖	€	❖
Cervap - Cervap GME 259	❖	❖	❖	€
Cervap DT 184	❖	€	❖	❖
Cervap DT 205	❖	❖	€	❖
Cervap DT 242	❖	❖	❖	€
Cervap XT 205	❖	❖	€	❖
Cervap XT 220	❖	❖	€	❖
Cervap XT 242	❖	❖	❖	€
Cervap XT 257	❖	❖	❖	€
Orion EvO 120	€	❖	❖	❖
Orion EvO 160	❖	€	❖	❖
Orion EvO 180	❖	€	❖	❖
Orion EvO 200	❖	❖	€	❖
Orion EvO 220	❖	❖	❖	€
Orion EvO 240	❖	❖	❖	€
<b>Loader-unloader for scissors type lifter</b>				
Cervap - Cervap GME 164	❖	€	❖	❖
Cervap - Cervap GME 186	❖	€	❖	❖
Cervap - Cervap GME 201	❖	❖	€	❖
Cervap - Cervap GME 222	❖	❖	€	❖
Cervap - Cervap GME 259	❖	❖	❖	€
Cervap DT 184	❖	€	❖	❖
Cervap DT 205	❖	❖	€	❖
Cervap DT 242	❖	❖	❖	€
Cervap XT 205	❖	❖	€	❖
Cervap XT 220	❖	❖	€	❖
Cervap XT 242	❖	❖	❖	€
Cervap XT 257	❖	❖	❖	€
Orion EvO 120 (except 5 decks)	€	❖	❖	❖
Orion EvO 160 (sauf 5 decks)	❖	€	❖	❖
Orion EvO 180 (except 5 decks)	❖	€	❖	❖
Orion EvO 200 (sauf 5 decks)	❖	❖	€	❖
Orion EvO 240 (except 5 decks)	❖	❖	❖	€

# Stainless steel loader-unloader

## Doors width of 750 mm

### Selection table of loader-unloader kit with belt , according to type of lifter and hooks

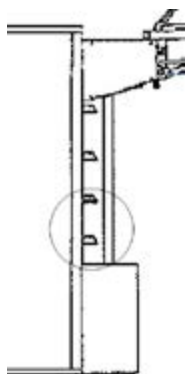
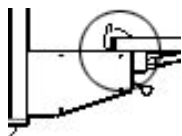
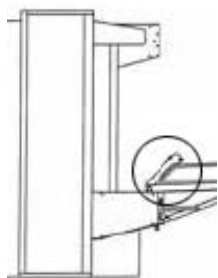

Stainless steel loader-unloader for 750mm door width ovens

Depth of loader-unloader

1886 mm    2256 mm    2626 mm    3015 mm

<b>Loader-unloader for standard integrated lifter with tilting hooks</b>				
Cervap 149	❖	€	❖	❖
Cervap - GME 186	❖	❖	€	❖
Cervap - GME 222	❖	❖	❖	€
Cervap DT 184	❖	❖	€	❖
Cervap DT 205	❖	❖	€	❖
Cervap DT 242	❖	❖	❖	€
Cervap XT 205	❖	❖	€	❖
Cervap XT 220	❖	❖	❖	€
Cervap XT 242	❖	❖	❖	€
<b>Loader-unloader for standard integrated lifter with fixed hooks</b>				
Cervap 149	❖	❖	€	❖
Cervap - GME 186	❖	❖	❖	€
Cervap DT 184	❖	❖	❖	€
Cervap DT 205	❖	❖	❖	€
Cervap XT 205	❖	❖	❖	€
<b>Loader-unloader for standard integrated lifter without hooks</b>				
Cervap 149	€	❖	❖	❖
Cervap - GME 186	❖	€	❖	❖
Cervap - GME 222	❖	❖	€	❖
Cervap - GME 259	❖	❖	❖	€
Cervap DT 184	❖	€	❖	❖
Cervap DT 205	❖	❖	€	❖
Cervap DT 242	❖	❖	❖	€
Cervap XT 205	❖	❖	€	❖
Cervap XT 220	❖	❖	€	❖
Cervap XT 242	❖	❖	❖	€
Cervap XT 257	❖	❖	❖	€
<b>Loader-unloader for manual loader base / scissors type lifter / M83</b>				
Cervap 149	€	❖	❖	❖
Cervap - GME 186	❖	€	❖	❖
Cervap - GME 222	❖	❖	€	❖
Cervap - GME 259	❖	❖	❖	€
Cervap DT 184	❖	€	❖	❖
Cervap DT 205	❖	❖	€	❖
Cervap DT 242	❖	❖	❖	€
Cervap XT 205	❖	❖	€	❖
Cervap XT 220	❖	❖	€	❖
Cervap XT 242	❖	❖	❖	€
Cervap XT 257	❖	❖	❖	€

# Stainless steel loader-unloader

Doors width of 800 mm

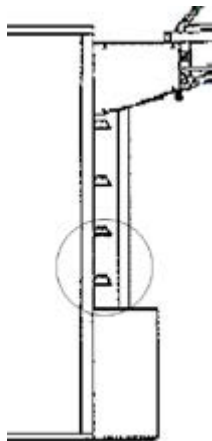
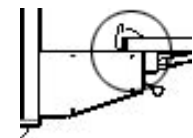
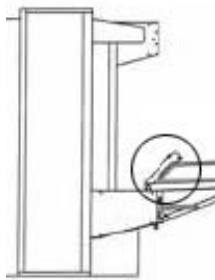

## Selection table of loader-unloader kit with belt , according to type of lifter and hooks

Stainless steel loader-unloader for 800mm door width ovens

Depth of loader-unloader

1886 mm    2256 mm    2626 mm    3015 mm

	1886 mm	2256 mm	2626 mm	3015 mm
<b>Loader-unloader for standard integrated lifter with tilting hooks</b>				
Compact - Compact GME 123	€	❖	❖	❖
Compact - Compact GME 143	❖	€	❖	❖
Cervap 162	❖	€	❖	❖
Cervap 202	❖	❖	€	❖
Cervap 242	❖	❖	❖	€
Orion EvO 120	€	❖	❖	❖
Orion EvO 160	❖	€	❖	❖
Orion EvO 180	❖	❖	€	❖
Orion EvO 200	❖	❖	€	❖
Orion EvO 220	❖	❖	❖	€
Orion EvO 240	❖	❖	❖	€
<b>Loader-unloader for standard integrated lifter with fixed hooks</b>				
Compact - Compact GME 123	❖	€	❖	❖
Compact - Compact GME 143	❖	❖	€	❖
Cervap 162	❖	❖	€	❖
Cervap 202	❖	❖	❖	€
Orion EvO 120	❖	€	❖	❖
Orion EvO 160	❖	❖	€	❖
Orion EvO 180	❖	❖	❖	€
Orion EvO 200	❖	❖	❖	€
Orion EvO 220	❖	❖	❖	€
<b>Loader-unloader for standard integrated lifter without hooks</b>				
Compact - Compact GME 123	€	❖	❖	❖
Compact - Compact GME 143	€	❖	❖	❖
Cervap 162	❖	€	❖	❖
Cervap 202	❖	❖	€	❖
Cervap 242	❖	❖	❖	€
Orion EvO 120	€	❖	❖	❖
Orion EvO 160	❖	€	❖	❖
Orion EvO 180	❖	€	❖	❖
Orion EvO 200	❖	❖	€	❖
Orion EvO 220	❖	❖	❖	€
Orion EvO 240	❖	❖	❖	€
<b>Loader-unloader for manual loader base / scissors type lifter / M83</b>				
Compact - Compact GME 123	€	❖	❖	❖
Compact - Compact GME 143	€	❖	❖	❖
Cervap 162	❖	€	❖	❖
Cervap 202	❖	❖	€	❖
Cervap 242	❖	❖	❖	€
Orion EvO 120	€	❖	❖	❖
Orion EvO 160	❖	€	❖	❖
Orion EvO 180	❖	€	❖	❖
Orion EvO 200	❖	❖	€	❖
Orion EvO 220	❖	❖	❖	€
Orion EvO 240	❖	❖	❖	€

# Soleo EvO



Soleo EvO M4 Soleo EvO M4 «Bread» deck with hood



Soleo EvO M4 «Bread» deck with hood and integrated lifter

## Modular deck oven - Electric

### Performance

- Baking area : from 0,5 to 1,98 m<sup>2</sup> (per deck depending on models)
- Useful height :
  - 180 or 240 mm (pastry deck)
  - 180 or 225 mm (bakery deck)
- Number of decks: from 1 to 5  
In case of 5 deck configuration, there can only be a maximum of 2 high crown H240 decks
- Plates 400 x 600 mm : every models
- Plates 460 x 660 mm : every models except M2 Shop EvO

### The advantages

- Configurable oven depending on user's needs
- Excellent & uniform baking quality
- Versatile
- Possibility to order a separate independent deck which can be added to the original configuration
- High baking capacity
- Easy cleaning
- Possibility to use an integrated lifter («Bread» deck only)
- Screen Touch 7" control panel
- Can be mounted on stand or proofer (depending on model)
- Steam condenser available as option
- Deferred startup of the oven
- 3 years warranty on heating elements in baking chamber
- May be combined with a Krystal convection oven

### Use

Soleo EvO is an electric Modular type deck oven designed to bake all types of breads, pastries and Danish products. Available in 5 models, it is compatible with 400 x 600 or 460 x 660 mm trays. It can be configured according to the user's needs: «bread» deck (push door) or «pastry» deck (pull door), number of decks, deck height, with or without steam, on stand or on a proofer, with or without drawer, with or without integrated lifter. It's modular conception allows the oven to be upgraded at a later time.

### Operating principle

Soleo EvO consist of baking units stacked on top of each other. Lower and/or upper elements can be added to create a customised oven. Each deck is fitted with refractory concrete hearth plates 20 mm thick to ensure an excellent baking quality.

### Construction

- Front :**
- All in brushed stainless steel

### «Bread deck» - M2 EvO, M3 EvO, M4 EvO, M6 EvO models

- «Bread» deck : automatic opening and closing system driven by the ramp of the loader-unloader
- New ergonomic door handle
- 20 mm thick refractory hearthplate
- Removable windows with special cleaning position
- Halogen interior lighting
- Stainless steel highly performing heating elements

### «Pastry» deck M2 EvO Shop, M3 EvO, M4 EvO, M6 EvO

- «Pastry» deck opening: pull door
- 20 mm thick refractory hearthplate
- Halogen interior lighting
- Stainless steel highly performing heating elements

### Control panel

- 1 touch screen control panel 7" for the entire oven (Sensitiv'2)
- 1 electromechanical control panel per deck (Ergocom)

### Steam generator

- 1 powerful steam generator per deck
- 1 integrated water meter on each deck (only available with Sensitiv'2)
- Water pressure reducing valve kit
- Steam injection at the rear of the baking chamber, avoiding water droplet on the dough
- Water filter delivered complete with cartridge

### Insulation

- Crossed rock wool panels
- Reflective glass treatment

# Modular deck oven **Soleo Evo**

Models	M2 Evo	M3 Evo	M4 Evo	M6 Evo
<b>Access to heating elements / steam generators / door handles / control panel</b>				
All on the right hand side (facing the oven)	•	•	•	•
<b>Control units</b>				
7" Sensitiv'2 touchscreen control (one central control per oven)	•	•	•	•
Ergocom controls (one control per deck)	€	€	€	€
7" Sensitiv'2 touchscreen control (one control per deck)	€	€	€	€
<b>Type of door opening</b>				
<b>«Pastry» style (available at a later stage)</b>				
- Low crown deck 180 mm	•	•	•	•
- High crown deck 240mm	€	€	€	€
<b>«Bread» style</b>				
- Low crown deck 180mm	€	€	€	€
- High crown deck 225mm	€	€	€	€
Option double handles per deck	-	€	€	•
<b>Baking deck equipment</b>				
Decompression on each deck	•	•	•	•
Motorised steam vent on each deck	•	•	•	•
<b>Steam</b>				
Independent steam generator per deck	€	€	€	€
<b>Top elements (headband or hood required)</b>				
Ornamental headband	€	€	€	€
Hood without extractor	€	€	€	€
Hood with extractor	€	€	€	€
Hood with steam condenser	Consult us			-
<b>Oven stand including insulated base frame + technical module</b>				
Base 475 mm	€	€	€	€
Base 635 mm	€	€	€	€
Base 815 mm	€	€	€	€
Base 975 mm	€	€	€	€
<b>Options</b>				
Tray storage rack (only available for oven stand H 975 mm)	€	€	€	€
Electromechanical proofbox with hygrostat (only suitable with the 975 mm tall oven stand)	Consult us			
Drawer(s) (not compatible with stainless steel oven stand cladding)	€	€	€	€
S/S oven stand cladding (front only)	€	€	€	€
<b>Mechanical loader lifting system (for «Bread» style decks only)</b>				
<b>Full Width loading</b>				
Integrated lifter for Full Width Loading	€	€	€	-
Fixed hooks on oven facade - per deck for full width loading	€	€	€	-
Loader-unloader for belt with rod - full width loading	€	€	€	-
<b>Half Width loading</b>				
Integrated lifter for Half Width Loading	-	€	€	€
Fixed hooks on oven facade - per deck for half width loading	-	€	€	€
Loader-unloader for belt with rod - half width loading	-	€	€	€
<b>Manual loading (without lifter)</b>				
Half-width loader (angle bar style belt unrolling)	€	€	€	€
Compatible with the «pastry» style door opening	•	•	•	•
Compatible with the «bread» style door opening	o	o	o	o
<b>Accessories</b>				
Anti-scale filter fitted with a cartridge	€	€	€	€
Energy management optimiser	€	€	€	€
Compatible with a CTM system (Centralised Technical Management)	•	•	•	•
<b>Combination ovens</b>				
With convection oven Krystal	Consult us	-	Consult us	-
With Pizza deck	Consult us	-	Consult us	-
<b>Upgradability</b>				
Add an additional independant deck on an existing oven	Consult us			
<b>Panels</b>				
Stainless steel oven front (excluding panel with oven controls) and pre-lacquered sheet metal side paneling	•	•	•	•
Full stainless steel oven cladding per deck (excluding panel with oven controls)	€	€	€	€
<b>Assembly</b>				
Oven to be assembled on site	•	•	•	•
Factory assembled oven	€	€	€	€
<b>Mains Voltage</b>				
3N~400V	•	•	•	•
1N~230V	-	-	-	-

• Standard // o Option without extra charge // € Option with extra charge // - Not available

# Modular deck oven **Soleo EvO**

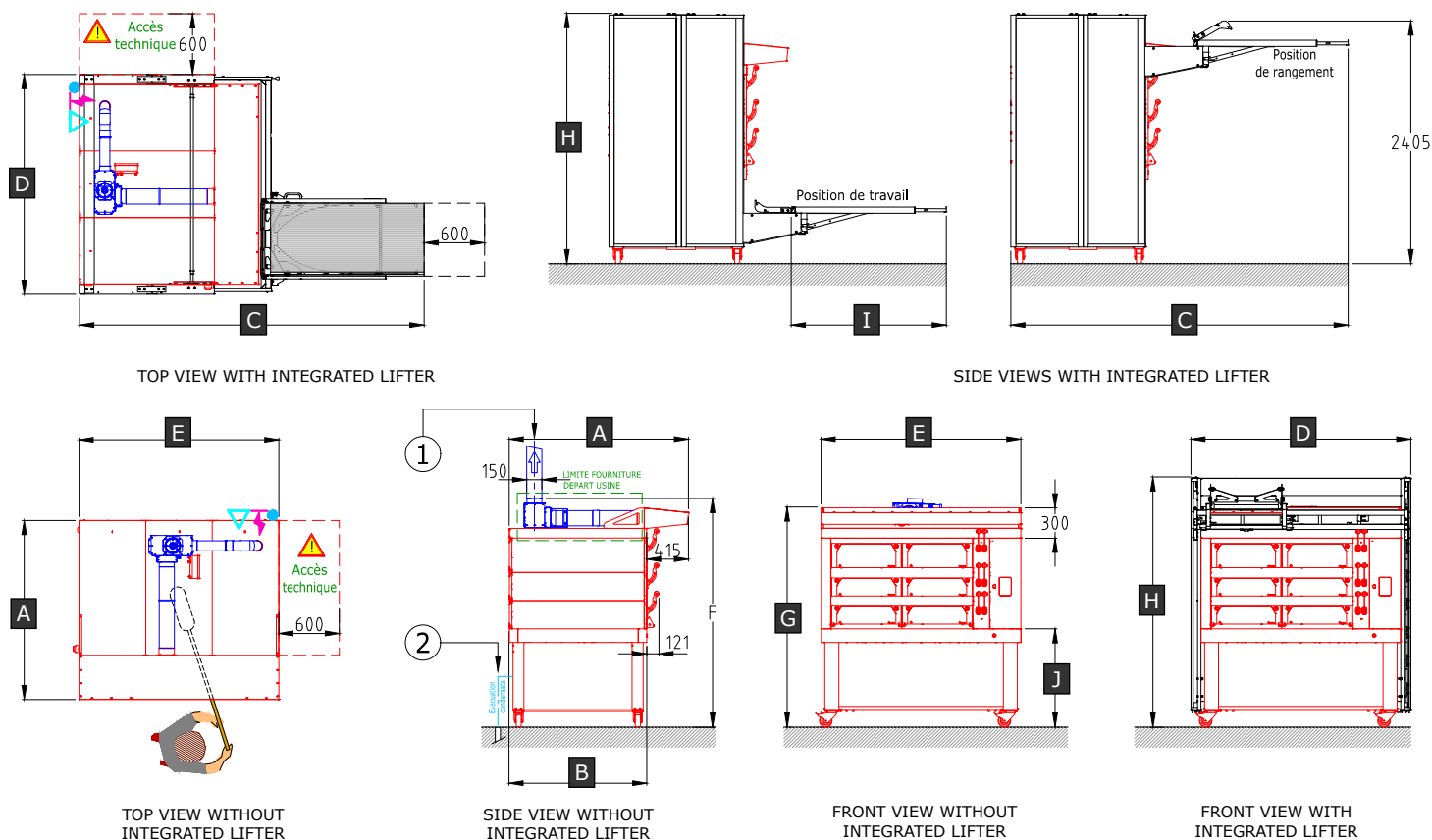

① The outlet diameter is to be determined by the chimney flue specialist. Extraction between 300 and 400<sup>3</sup>/h. If pipe length > 10, an exhaust turret must be provided on the roof. Do not use a non-return check valve.

② Condensate discharge to the floor drain is the customer's responsibility

- Condensate drainage Ømm (min. 50) (resistance > 90°C)
- ⚡ Electrical power supply direct on the base. Cable roughed-in at floor level + 1.50 – copper wire mandatory
- ▽ Cold water supply on base with shut-off valve
- ⚙ Steam discharge Ø 150 mm

**SOLEO!**

## CHARACTERISTICS OF OVENS WITHOUT LIFTER

			M2 EvO	M3 EvO	M4 EvO	M6 EvO
Width						
<b>E</b>	Overall width	(mm)	1510	1978	1978	1978
Depth						
-	With pastry opening headband	(mm)	1084	983	1248	1728
<b>B</b>	With baking opening headband*	(mm)	1202	1101	1366	1846
-	With pastry opening hood	(mm)	1452	1351	1616	2096
<b>A</b>	With baking opening hood*	(mm)	1617	1516	1781	2261

## TECHNICAL CHARACTERISTICS OF THE OVEN WITH INTEGRATED LIFTER AND OVEN LOADER IN STORAGE POSITION

			M2 EvO	M3 EvO	M4 EvO	M6 EvO
<b>C</b>	Oven depth	(mm)	3000	2810	3345	4325
<b>D</b>	Oven width	(mm)	1710	2178	2178	2178
<b>H</b>	Height	(mm)	2480	2480	2480	2480
<b>I</b>	Loader length	(mm)	1298	1198	1463	1943

## CONNECTION CAPACITY

Electrical power of a deck with alternating deck/crown heating						
	Without steam	(kW)	3,9	4,9	7	9,2
	With steam	(kW)	5,9	6,9	9	12,2

\*without handle, with or without steam (including stove-setting)

## Modular deck oven **Soleo EvO**

		M2 EvO	M3 EvO	M4 EvO	M6 EvO
Useful baking dimensions					
Useful baking width	(mm)	935	1400	1400	1400
Useful baking depth	(mm)	770	670	935	1415
Nb of baking trays per deck					
400 x 600		2	3	4	6
460 x 660		2	3	4	6
460 x 760		2	1	3	4
GN 530 x 650		1	2	2	4
Baking area					
Baking area per deck	(m <sup>2</sup> )	0,72	0,94	1,31	1,98

### Overall height of the Soleo EvO range (withtout integrated lifter)

Number of lower deck	Number of upper deck	Overall height of the decks (mm)	Total number of decks	Stand height (J) (mm)	Headband height (mm)	Hood height (mm)	Oven height with hood (G) (mm)	First deck loading height (mm)	Last deck loading height (mm)
1	0	280	1	975	95	205	-	1018	1018
2	0	560	2	975	95	205	-	1018	1298
3	0	840	3	975	95	205	2115	1018	1578
4	0	1120	4	635	95	205	-	678	1518
5	0	1400	5	475	95	205	2175	518	1638
0	1	340	1	975	95	205	-	1018	1018
0	2	680	2	975	95	205	-	1018	1358
0	3	1020	3	815	95	205	2135	858	1538
0	4	1360	4	475	95	205	2135	518	1538
1	1	620	2	975	95	205	-	1018	1298
2	1	900	3	975	95	205	2175	1018	1578
3	1	1180	4	635	95	205	2115	678	1518
4	1	1460	5	475	95	205	2235	518	1638
1	2	960	3	975	95	205	2235	1018	1638
1	3	1300	4	635	95	205	2235	678	1638
2	2	1240	4	635	95	205	2175	678	1578
3	2	1520	5	475	95	205	2295	518	1698

Remark: the hood's bottom has to be higher or equivalent at 1900 mm. Thus the hood is not compatible with oven with a lower height.



# EXAMPLE OF SOLEO EVO M4 CONFIGURATION

## 2 bottom decks + 1 top deck with lifter



	Quantity
<b>Control units</b>	
7" Sensitiv'2 touchscreen control (one central control per oven)	•
<b>Type of door opening</b>	
<b>«Bread» style</b>	
- Low crown deck 180mm	2
- High crown deck 225mm	1
Independent steam generator per deck	3
Option double handles per deck	3
<b>Top elements (headband or hood required)</b>	
Hood with extractor	1
<b>Bottom Elements</b>	
Base + technical model HT 975 mm	1
Stainless steel oven stand cladding HT 975 mm (front only)	1
<b>Mechanical loader lifting system (for «Bread» style decks only)</b>	
Half Width loading	
Integrated lifter for Half Width Loading	1
Loader-unloader for belt with rod – half width loading	1
<b>Accessories</b>	
Anti-scale filter fitted with a cartridge	1

# EXAMPLE OF SOLEO EVO M4 CONFIGURATION

## 3 top decks without lifter



	Quantity
<b>Control units</b>	
7" Sensitiv'2 touchscreen control (one central control)	1
<b>Type of door opening</b>	
<b>«Bread» style</b>	
- High crown deck 225mm	3
Independent steam generator per deck	3
Option double handles per deck	3
<b>Top elements (headband or hood required)</b>	
Hood with extractor	1
<b>Bottom Elements</b>	
Base + technical model HT 815 mm	1
Drawer(s) (not compatible with stainless steel oven stand cladding)	1
<b>Accessories</b>	
Anti-scale filter fitted with a cartridge	1

# Soleo



## Modular deck oven - Electric

### Performances

- Baking area : from 0,5 to 6,8 m<sup>2</sup>
- Useful baking chamber height on each deck : 180 or 240 mm
- Number of decks : from 1 to 4 (5 decks possible only with 180 mm decks)

### The advantages

- Configurable oven depending on user's needs
- Baking quality comparable to that of traditional masonry ovens
- Oven stand on castors for easy moving into place
- Upgradable
- Can be mounted on a stand, BFA reach-in retarder-proofer or manual S/S proofbox, depending on the model
- Very efficient independent steam generator
- Deferred startup of the oven
- 3 years warranty on heating elements in baking chamber
- May be combined with a Krystal convection oven

### Use

Soleo is an electric Modular type deck oven designed to bake all types of breads, pastries and Danish products. Available in 2, 4 or 6 trays 400x600 mm or 3 trays 460x660 / 460x760 mm trays, it can be configured according to the user's needs: number of decks, deck height, with or without steam, on stand or on a proofer. It's modular conception allows the oven to be upgraded at a later time.

### Operating principle

Good distribution of heating elements, dual Top & Bottom heat regulation, refractory concrete hearth plates 20 mm thick make it an oven of its own or usable as a back-up oven capable of competing with any large deck oven / setter oven in terms of baking quality.

### Construction

- Front :**
- polished stainless steel
  - removable glass doors

**Baking chamber standard :**

- refractory concrete hearth plates 20 mm thick
- halogen lighting
- stainless steel highly performing heating elements guaranteed 3 years

**Steam generator :**

- independent
- 1 per deck

**Insulation :**

- crossed rock wool panels
- tempered glass to reduce heat losses

• • • **important notes :**

The BFA retarder-proofer is directly derived from the standard reach-in retarder-proofer line, with same OPTICOM controls & functions.

# Modular deck oven **Soleo**

<i>Models</i>	<i>M2</i>	<i>M3</i>	<i>M4</i>	<i>M6</i>
<b>Control</b>				
Electronic control Opticom on the right side	■	■	■	■
Ergocom control on the right side	€	€	€	€
<b>Upper elements</b>				
Hood with exhaust fan	€	€	€	€
Hood without exhaust fan	€	€	€	€
Headband	€	€	€	€
<b>Deck without steam generator</b>				
lower deck 180 mm	€	€	€	€
upper deck 240 mm	€	€	€	€
<b>Steam generator</b>				
Independent steam generator (per deck)	€	€	€	€
<b>Stand without tray storage</b>				
H 540 mm	€	€	€	€
H 660 mm	€	€	€	€
H 720 mm	€	€	€	€
<b>Stand with tray storage</b>				
<b>Tray 400 x 600</b>	■	❖	■	■
<b>Tray 460 x 660</b>	❖	■	€	€
H 780 mm	€	€	€	€
H 880 mm	€	€	€	€
H 940 mm	€	€	€	€
H 1000 mm	€	€	€	€
H 1060 mm	€	€	€	€
<b>Proofbox</b>				
Manual stainless steel proofbox	€	€	€	€
<b>Integrated lifter</b>				
Integrated lifter	❖	€	€	€
Loader-unloader for integrated lifter	❖	€	€	€
Aluminium loader only	€	€	€	€
<b>Assembly</b>				
Built on site	■	■	■	■
2 decks	€	€	€	€
3 decks	€	€	€	€
4 decks	€	€	€	€
<b>Power supply</b>				
3N~400V	■	■	■	■

■ **Importante notes:**

The stand for modular deck oven M3 with tray storage is only available for 460 x660 mm tray size.

# Modular deck oven **Soleo**

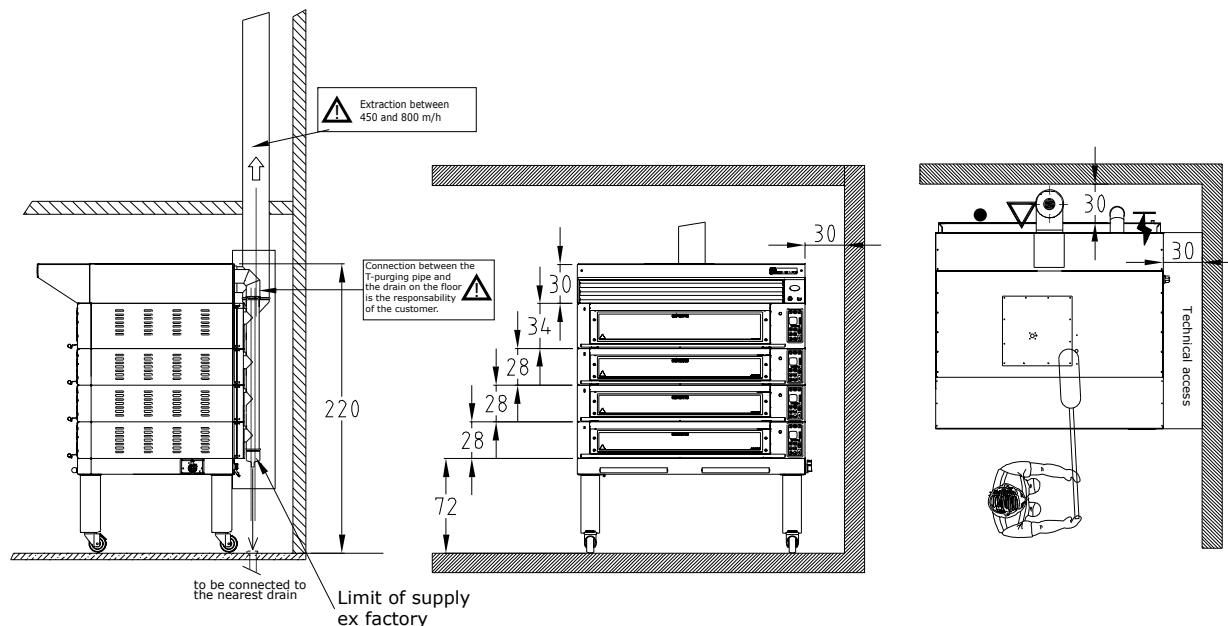

- Water drain, Ø 100 mm.
- ⚡ Electrical connection from the ceiling, 1 m from the floor.
- ▽ Cold water connection from the ceiling. To be connected to a cold water drain Ø 3/4". Pressure : 2.5-4 bars
- ⊙ In case of oven with steam generator : steam exhaust duct at 700 mm from the floor.
- ⊙ Oven with steam exhaust hood: steam exhaust duct Ø 200 mm. Extraction between 450-800 m<sup>3</sup>/h or 15892-28252 ft<sup>3</sup>/h.

● ● ● **Important remark:**

Required technical access above oven: 600 mm

## Technical features

		M2	M3	M4	M6
<b>Width</b>					
Oven width	(mm)	980	1815	1730	1610
Useful baking width	(mm)	620	1455	1370	1250
<b>Overall depth, with or without steam generator (incl. of steam duct at rear of oven)</b>					
Depth with hood	(mm)	1718	1718	1838	2223
Depth with headband	(mm)	1405	1405	1526	1910
Useful depth of baking chamber	(mm)	845	845	965	1350
<b>Total power of all heating elements</b>					
Baking deck 180/240 m	(kW)	6,02	13,92	15,02	17,08
Steam generator	(kW)	1	2	2	2
<b>Electric connecting power per deck (without steam), in cyclematic power mode for top and bottom heat</b>					
Without steam	(kW)	3,18	7	7,55	8,58
With steam	(kW)	4,18	9	9,55	10,58
Voltage (all models)		3N~400V / 3~230V			
<b>Tray capacity per deck</b>					
400 x 600		2	4	4	6
460 x 660		1	3	4	4
460 x 760		1	3	2	3
580 x 780		1	2	2	2
GN 530 x 650		1	2	2	4
Baking area / deck (1m <sup>2</sup> =10.764 ft <sup>2</sup> )	(m <sup>2</sup> )	0,52	1,23	1,32	1,69

# Accessories Modular oven Soleo

## Hoods

Ornamental hood without lighting

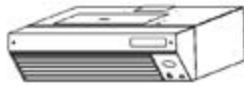

<i>Model</i>		<i>M2</i>	<i>M3</i>	<i>M4</i>	<i>M6</i>
Width	(mm)	980	1816	1730	1610
Height	(mm)	300	300	300	300
Depth	(mm)	1430	1430	1550	1930
Electric power	(W)	155	155	155	155
Weight	(kg)	63	93	96	106

Hood with exhaust fan and lighting



<i>Model</i>		<i>M2</i>	<i>M3</i>	<i>M4</i>	<i>M6</i>
Width	(mm)	980	1816	1730	1610
Height	(mm)	300	300	300	300
Depth	(mm)	1430	1430	1550	1930
Electric power	(W)	35	35	35	35
Weight	(kg)	33	53	54	60

## Ornamental headband



<i>Model</i>		<i>M2</i>	<i>M3</i>	<i>M4</i>	<i>M6</i>
Width	(mm)	980	1816	1730	1610
Height	(mm)	100	100	100	100
Depth	(mm)	1200	1200	1320	1705
Weight	(W)	22	37	39	45

## Baking chamber

<i>Model</i>		<i>M2</i>	<i>M3</i>	<i>M4</i>	<i>M6</i>
<b>Baking deck 180</b>					
Height (deck - overall)	(mm)	280	280	280	280
Height (chamber - inside)	(mm)	180	180	180	180
Useful height (door clearance)	(mm)	168	168	168	168
Weight without steam generator	(kg)	75	200	210	240
Weight with steam generator	(kg)	95	230	240	270
<b>Baking deck 240</b>					
Height (deck - overall)	(mm)	340	340	340	340
Height (chamber - inside)	(mm)	240	240	240	240
Useful height (door clearance)	(mm)	228	228	228	228
Weight without steam generator	(kg)	85	210	220	250
Weight with steam generator	(kg)	105	240	250	280
Height from base of baking	(mm)	41	41	41	41

## Hearthplates

<i>Model</i>		<i>M2</i>	<i>M3</i>	<i>M4</i>	<i>M6</i>
Dimensions (depth x width)	(mm)	845 x 620	845 x 1455	956 x 1370	1350 x 1250
Thickness	(mm)	20	20	20	20
Weight	(kg)	24	56	61	78

# Accessories Modular oven Soleo

## Stands

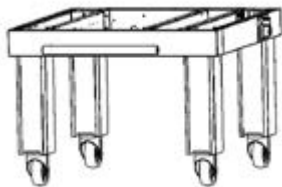

<b>Stands without tray storage</b>					
Height (540 mm)		<b>M2</b>	<b>M3</b>	<b>M4</b>	<b>M6</b>
Weight	(kg)	67	102	104	115
<b>Height (660 mm)</b>					
Weight	(kg)	72	108	110	121
<b>Height (720 mm)</b>					
Weight	(kg)	75	118	121	134
<b>Stands with tray storage</b>					
Height (780 mm)		<b>M2</b>	<b>M3</b>	<b>M4</b>	<b>M6</b>
Weight	(kg)	100	172	159	168
<b>Height (880 mm)</b>					
Weight	(kg)	105	176	164	173
<b>Height (940 mm)</b>					
Weight	(kg)	108	179	167	176
<b>Height (1000 mm)</b>					
Weight	(kg)	111	182	170	179
<b>Height (1060 mm)</b>					
Weight	(kg)	113	185	173	182
Width	(mm)	980	1816	1730	1610
Depth	(mm)	1150	1150	1250	1650

## Manual stainless steel proofbox

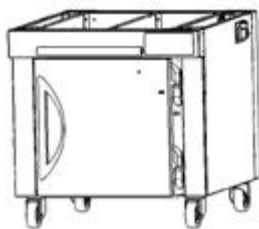

<b>Model</b>		<b>M2</b>	<b>M3</b>	<b>M4</b>	<b>M6</b>
Width	(mm)	980	1816	1730	1610
Height	(mm)	1000	1000	1000	1000
Depth	(mm)	1120	1120	1240	1630
<b>Proofbox capacity (spacing = 65 mm)</b>					
400 x 600		14	-	28	28
460 x 660		-	28	-	-
Number of door		1	2	2	2
Electric power	(W)	775	1250	1250	1250
Temperature		20 / +40 °C			
Weight	(kg)	225	350	300	375
Humidity system		Manual	Manual	Manual	Manual

# Modular oven **Soleo** M2-M3-M4-M6

**Possible configurations - Standard height : 2 200 mm**  
**- Standard width : 980 mm**

**4 decks**

**3 decks**

**Hood 300 mm**  
**Deck 280 mm**  
 (180 mm useful)

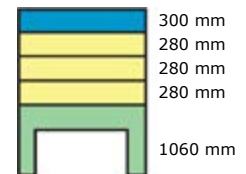

**Hood 300 mm**  
**Deck 340 mm**  
 (240 mm useful)

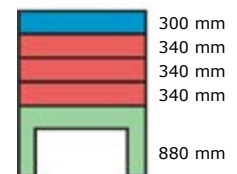
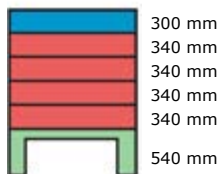

**Hood 300 mm**  
**Mixed decks**  
**280 mm - 340 mm**

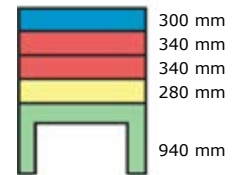
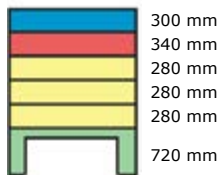

**Hood 300 mm**  
**Mixed decks**  
**280 mm - 340 mm**

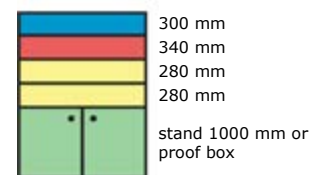
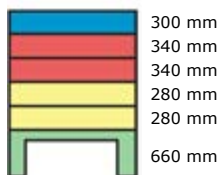



# Modular oven **Soleo** M2-M3-M4-M6

**Possible configurations - variable total heights**  
**- Standard width : 980 mm**

## 3 decks

**Headband 100 mm**  
**Deck 280 mm**  
 (180 mm useful)

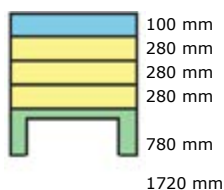

**Headband 100 mm**  
**Mixed decks**  
**280 mm - 340 mm**  
 (180 mm - 240 mm Useful)

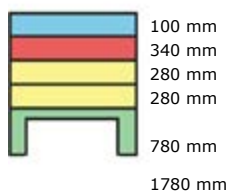

**Headband 100 mm**  
**Mixed decks**  
**280 mm - 340 mm**  
 (180 mm - 240 mm Useful)

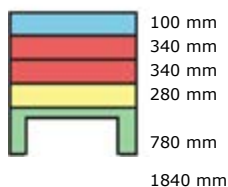

**Headband 100 mm**  
**Mixed decks**  
**280 mm - 340 mm**  
 (180 mm - 240 mm Useful)

## 2 decks

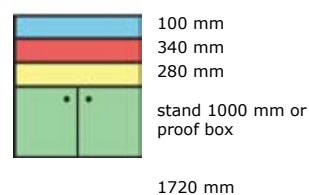
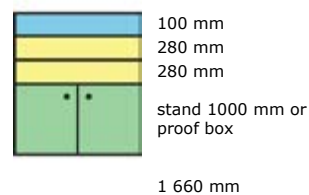
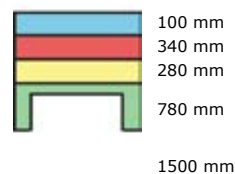
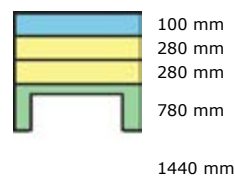

# Integrated lifter



Configurable  
upon request  
(3 or 4 Decks  
only).  
6 weeks for  
ex-works  
delivery

for modular deck ovens Soleo

## Performances

Designed for modular oven Soleo M3, M4 and M6

## Use

Designed only for the Soleo modular deck ovens.  
The integrated lifter is used to load and unload the baking chambers

## Operating principle

Lifting system with chains and counterweight  
Loader supplied with belt.

## Construction

- Aluminium structure

## • • • Important notes :

There is no intergrated lifter for the Soleo M2 modular deck oven.

## The advantages

- It is possible for one person to load, in one movement, the whole deck.
- Easy to store
- Compact
- Easy to use

## Integrated lifter for modular deck oven Soleo

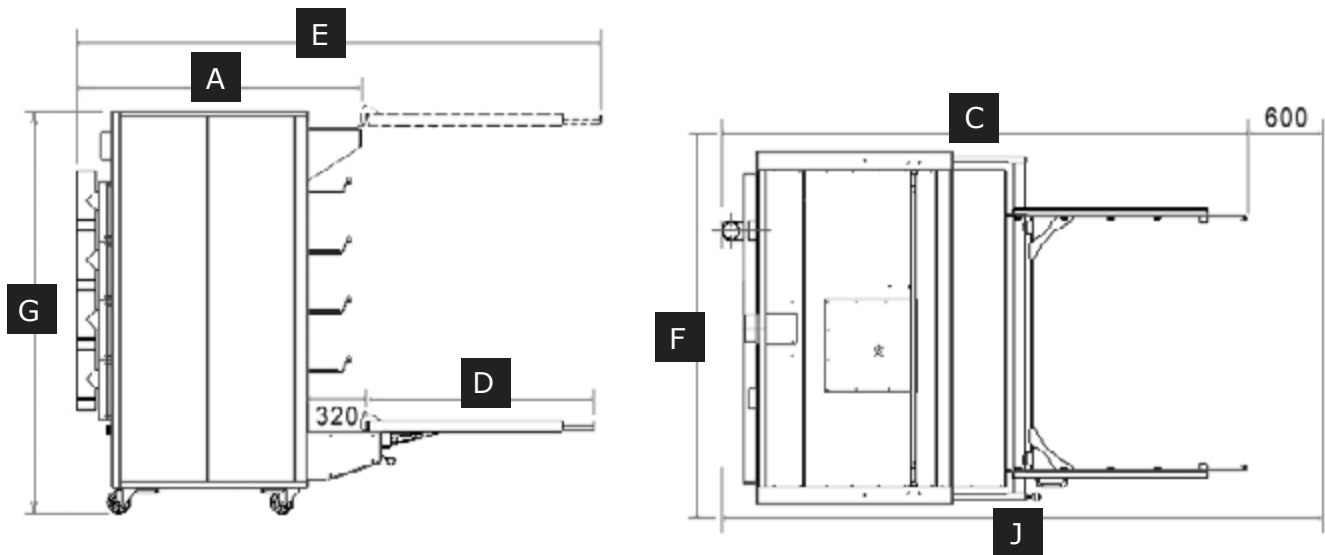

### Technical features

Modèles	A	C	J	D	E	F	G	
<b>M2</b>	No integrated lifter for the Soleo M2 modular oven							
<b>M3</b>	(mm)	1718	3093	3693	1371	3258	2015 +350	2320
<b>M4</b>	(mm)	1838	3380	3980	1535	3545	1930 +350	2320
<b>M6</b>	(mm)	2223	4025	4625	1915	4190	1810 +350	2470

### Example of loading height with 4 decks of 240mm (useful height)

Models	M3	M4	M6	
Top deck	(mm)	1601	1601	1746
Third deck	(mm)	1261	1261	1407
Second deck	(mm)	921	921	1067
First deck	(mm)	581	581	727
Minimum oven stand height	(mm)	540	540	686
Space available under the loader when in the high (storage) position	(mm)	1870	1970	2052

# Loader unloader

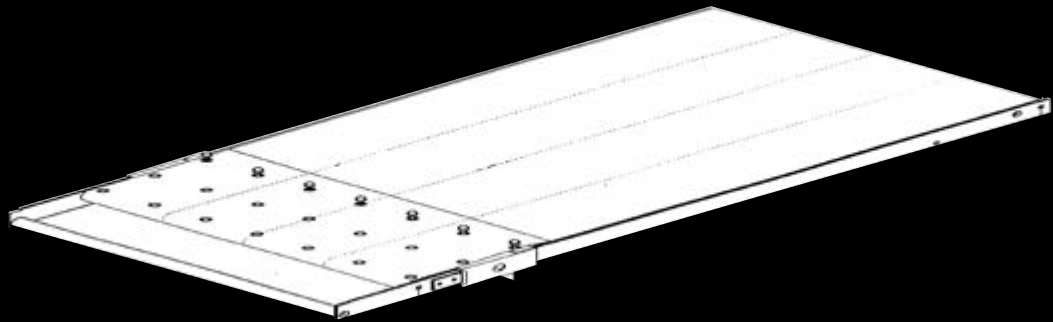

## Modular deck ovens Soleo

### Performances

For Modular deck ovens Soleo  
M3, M4 and M6

### The advantages

- Manual "single width" loading or Integral "Full width" loading / unloading depending on model
- Compact
- Easy to use
- Easy to store

### Use

Designed only for the Soleo deck ovens.

### Operating principle

Full width aluminium loader-unloader for use with integrated lifter  
Used with the integrated lifter for Soleo modular oven, it offers the possibility of completely loading and unloading a deck in one single step.  
This function can only be used with models adapted to the integrated lifters.

### Construction

- Aluminium structure
- With the "Full-Width" loader-unloader, the "hooks" will have to be fitted on the integrated lifter

### • • • Important notes :

Full width loader-unloader is supplied with a belt unrolling rod located above the loader-unloader, that locks into the "hooks"

# Hand-held Loader



For modular deck ovens Soleo

## Use

Designed only for the Soleo deck ovens.

## Operating principle

"Single" width loader (only) with belt manipulated by one or two operators (without any use of lifter or loader base)

## Construction

- Aluminium and stainless steel structure

## • • • Important note :

Hand-held loader is supplied with belt unrolling "L" shaped angle iron located underneath the loader, that locks in between concrete hearthplate & backside of oven front.

## The advantages

- Manual "single width" loading or Integral "Full width" loading / unloading depending on model
- Compact
- Easy to use
- Easy to store

# Alcor Bake



## Convection, combi and steam baking oven

### Performances

- Tray size : 400x600 mm (GN 1/1 optional)
- Number of levels : 6 or 10 levels (7 or 11 for GN 1/1)

### The advantages

- 3 cooking modes: convection, combined and steam
- Automatic wash
- 7 fan speeds
- 10" touch control
- 115 recipes pre-recorded in the control system, sorted by category
- Ability to create up to 500 recipes with image
- Automatic steam vent opening management
- Multiple synchronised cooking operations (Stop Synchro')
- Multiple simultaneous cooking operations (Multi Chrono')
- Adjustable preheating up to 300 °C
- Available in electromechanical version

### Use

Alcor Bake is a mixed convection oven offering 3 baking modes: convection, combined or steam. It is intended for baking precooked bakery, pastry and viennese products. Its steam cooking mode also allows you to cook snacks and meals.

It is available in two models, 6 and 10 levels, compatible with 400x600 supports. The 400x600 slides can be replaced by GN 1/1 slides, increasing the capacity of the ovens to 7 and 11 levels. Baking can be programmed with a timer, or with a core temperature probe (included). To make it easier to get started, pre-recorded recipes are available in the control panel. These can then be customised according to your wishes.

Several automatic washing cycles are available, ensuring perfect cleanliness regardless of the level of dirt in the baking chamber. Designed to simplify your daily life, the Alcor Bake oven is full of features that will save you time, such as simultaneous and synchronised baking or regeneration cycles for example.

### Operating principle

The products are placed on grids, trays, nets or in tubs, then loaded into the ventilated cooking chamber.

In convection mode, dry air is guaranteed thanks to forced extraction of humidity.

In combined or steam mode, steam is produced continuously thanks to a system for injecting water directly onto the heat source, thus converting the water to steam. Once heated, the steam is diffused over the products via the fans.

Steam vent opening and closing can be managed manually or automatically depending on the desired humidity percentage.

### Construction

#### Front all polished stainless steel and glass

- Double-glazed door, tool-free removal of the inner glass for easy cleaning
- Handle on right or left (configured on order only)
- Condensate recovery and drain gutter

#### Baking chamber

- All 304 stainless steel
- Rounded bottom corners for easy cleaning
- Diamond point shaped rear and side plates, to prevent deformation
- Direction of ventilation alternates every 30 seconds to ensure homogeneous distribution of air
- Halogen lighting, easy to replace

#### Washing

- Automatic dosage of detergent product according to the selected cycle
- Integrated detergent tank

# Convection, combi and steam baking oven

## Alcor Bake



Models	Alcor Bake 6	Alcor Bake 10	Alcor Bake EM 6	Alcor Bake EM 10
<b>Control</b>				
10" touch control	•	•	-	-
Electromechanical control	-	-	•	•
<b>Ventilation</b>				
2 fan speeds (1,160 - 1,400 rpm)	-	-	•	•
7 fan speeds (810 - 1,440 rpm)	•	•	-	-
<b>Functionalities</b>				
Cooking modes: Recipes, Stop Synchro', Multi Chrono', Special cycles, Delta T	•	•	-	-
Preheat and temperature hold functions	•	•	-	-
Automatic wash	•	•	-	-
Automatic steam vent management	•	•	-	-
Softbaking function (semi-static baking)	•	•	-	-
HygroControl smart humidity management system	-	-	-	-
<b>Characteristics</b>				
400x600 slides, 6 levels	•	-	•	-
400x600 slides, 10 levels	-	•	-	•
GN 1/1 slides, 7 levels	€	-	€	-
GN 1/1 slides, 11 levels	-	€	-	€
Steam production by direct injection	•	•	•	•
Boosted steam production (boiler)	-	-	-	-
USB port	•	•	-	-
Height-adjustable feet	•	•	•	•
Halogen lamp	•	•	•	•
Option without anti-limescale filter*	-€	-€	-€	-€
<b>Accessories</b>				
Pin type sensor	€	€	-	-
Spraying head with automatic hose reel	-	-	-	-
External spraying head	€	€	€	€
12 bottles of 1kg of detergent Alclean**	•	•	-	-
1 bottle of 1 kg of anti-scale Alcal**	-	-	-	-
<b>Door</b>				
Handle on the left	•	•	•	•
Handle on the right	€	€	€	€
Condensate recovery and drain gutter	•	•	•	•
<b>Steam duct</b>				
Coupling with suitable pipe ø 150 mm	€	€	€	€
<b>Water evacuation</b>				
High-temperature water evacuation kit	€	€	€	€
<b>Hood</b>				
Hood with extrator	€	€	€	€
<b>Stand</b>				
Base without castors, H720 mm with adjustable tray holder for 6 or 12 trays	€	€	€	€
Base castors	€	€	€	€
Proofbox without castors H 730 mm	€	€	€	€
Castors for proofbox	€	€	€	€
<b>Oven supply voltage</b>				
3N~380-415 V 50/60 Hz	€	€	€	€

\* If the carbonate hardness KH of the water is less than 4 ° dH.

\*\* The warranty is subjected to the use of alclean and alkcal products

# Convection, combi and steam baking oven **Alcor Bake**

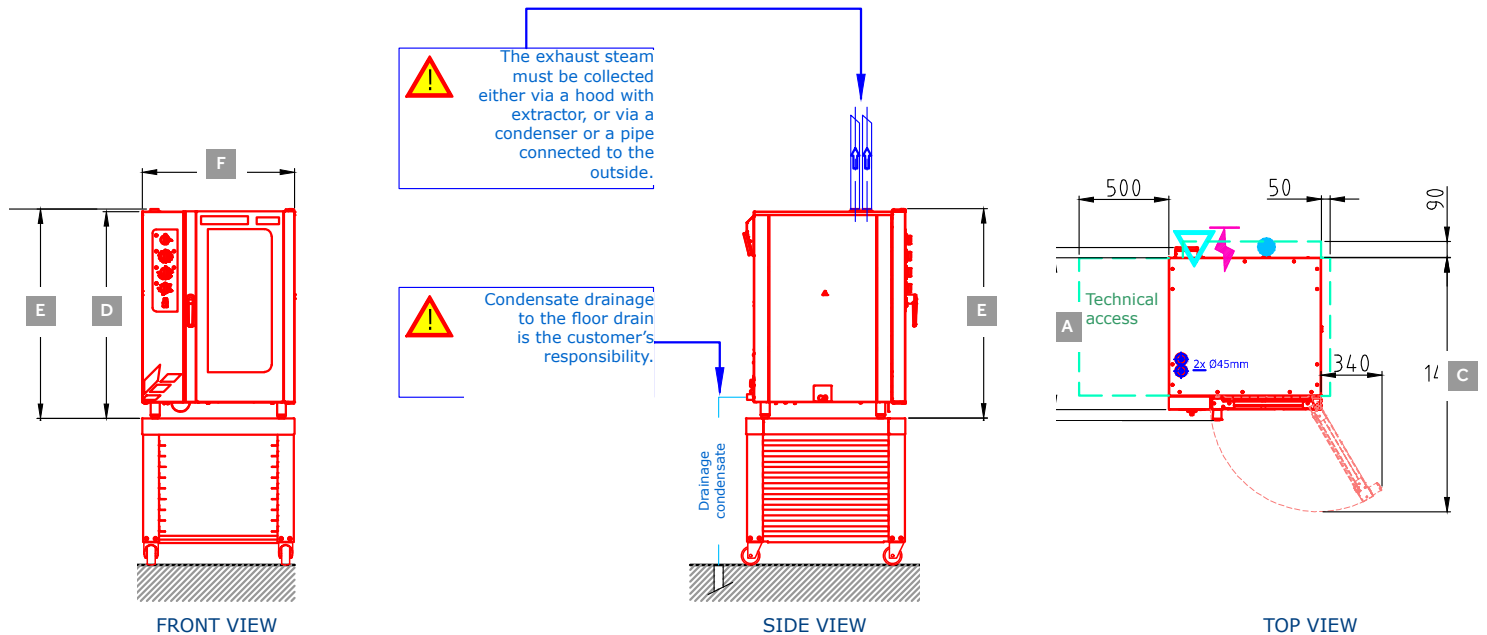

- Condensate drainage Ø 1" (resistance >90°C)
- ⚡ Direct electrical power supply by cable 5X4 mm<sup>2</sup> (H07RN-F) roughed-in at floor level + 1.50 m. Copper wire mandatory
- ▽ Cold water supply: Ø3/4" with shut-off valve
- Steam discharge Ø 45 mm interior

Dimensions and technical features			Alcor Bake 6		Alcor Bake 10		Alcor Bake EM 6		Alcor Bake EM 10	
<b>Oven</b>										
<b>A</b>	Depth	(mm)	845							
<b>B</b>	Overall depth	(mm)	960							
<b>C</b>	Total depth with door open	(mm)	1420							
<b>D</b>	Height	(mm)	870	1150	870	1150				
<b>E</b>	Overall height	(mm)	890	1170	890	1170				
<b>F</b>	Floor width	(mm)	850							
	Hood height	(mm)	330							
	Depth hood	(mm)	990							
	Hood weight	(kg)	49							
	Water connection (washing)	(inch)	3/4"							
	Softened water connection (steam)	(inch)	3/4"							
	Discharge	mm	32							
	Floor area	(m <sup>2</sup> )	0,72							
	Total oven weight	(kg)	95	132	90	125				
<b>Accessories</b>										
	Base height with castors	(mm)	820							
	Base height without castors	(mm)	720							
	Stand weight	(kg)	37							
	Proofbox height with castors	(mm)	746							
	Proofbox height without castors	(mm)	736							
	Weight of proofbox under the oven	(kg)	58							
<b>Energy characteristics</b>										
	Connection supply	(kW)	11	17	11	17				
	Proofbox connection supply	(kW)	1,5							
	Hood connection supply	(kW)	0,2							
	Electrical protection	(A)	20	32	20	32				
	Maximum operating temperature	(°C)	280							
	Maximum preheating temperature	(°C)	300				-			
<b>Water connection</b>										
	Pressure	(bar)	1,5 - 5							



## Convection, combi and steam baking oven **Alcor Bake**

Support specifications	Levels	Spacing (mm)	Max load (kg)	Maximum load
<b>400x600 mm support</b>				
Alcor Bake and Alcor Bake EM 6	6	80	30	5
Alcor Bake and Alcor Bake EM 10	10		45	
<b>GN 1/1 support (530x325 mm)</b>				
Alcor Bake and Alcor Bake EM 6	7	70	30	5
Alcor Bake and Alcor Bake EM 10	11		45	

Automatic wash	Time (min)	Water (L)	Alclean (g)
<b>6 levels</b>			
Quick cycle	20	17	90
Gentle cycle	36	26	180
Moderate cycle	52	37	270
Intensive cycle	67	46	360
<b>10 levels</b>			
Quick cycle	20	17	130
Gentle cycle	36	26	260
Moderate cycle	52	37	390
Intensive cycle	67	46	520

Pallet packaging (Carton)		Alcor Bake 6	Alcor Bake 10	Alcor Bake EM 6	Alcor Bake EM 10
Width	(mm)	915	915	915	915
Depth	(mm)	1000	1000	1000	1000
Height	(mm)	1045	1330	1045	1330
Total weight	(kg)	113	152	108	145

# Alcor Cook



## Convection, combi and steam baking oven

### Performances

- Tray size : 400x600 mm (GN 1/1 optional)
- Number of levels : 6 or 10 levels (7 or 11 for GN 1/1)

### The advantages

- 3 cooking modes: convection, combined and steam
- Steam production boosted by the boiler
- Hygro Control smart humidity management system
- Automatic wash
- 7 fan speeds
- 10" touch control
- 115 recipes pre-recorded in the control system, sorted by category
- Ability to create up to 500 recipes with image
- Automatic steam vent opening management
- Multiple synchronised cooking operations (Stop Synchro')
- Multiple simultaneous cooking operations (Multi Chrono')
- Adjustable preheating up to 300 °C

### Use

Alcor Cook is a mixed convection oven offering 3 cooking modes: convection, combined or steam. It is intended for cooking precooked bakery products, pastries, viennese pastries, along with snacks and meals.

Thanks to its high performance in low-temperature steam cooking mode, Alcor Cook also allows you to offer a true catering service. It is available in two models, 6 and 10 levels, compatible with 400x600 supports. The 400x600 slides can be replaced by GN 1/1 slides, increasing the capacity of the ovens to 7 and 11 levels. Cooking can be programmed with a timer, or with a core temperature probe (included). To make it easier to get started, pre-recorded recipes are available in the control panel. These can then be customised according to your wishes. Several automatic washing cycles are available, ensuring perfect cleanliness regardless of the level of dirt in the cooking chamber.

Designed to simplify your daily life, the Alcor Cook oven is full of features that will save you time, such as simultaneous and synchronised cooking or regeneration cycles for example.

### Operating principle

The products are placed on grids, trays, nets or in tubs, then loaded into the ventilated cooking chamber. In convection mode, dry air is guaranteed thanks to forced extraction of humidity. In combined or steam mode, steam is produced continuously thanks to two complementary systems: direct injection and the boiler.

- The direct water injection system injects water onto the heat source, converting it into steam. Once heated, the steam is diffused over the products via the fans.

- The boiler significantly improves oven performance and cooking results. The water is continuously heated until it boils, thereby transitioning to a vapour state. The hot steam is then injected directly into the cooking chamber. Thanks to the Hygro Control smart humidity management system, which takes into account the humidity released by the products during cooking, the quantity of steam to be injected or extracted is thus rigorously adjusted throughout cooking.

Steam vent opening and closing can be managed manually or automatically depending on the desired humidity percentage.

### Construction

#### Front all polished stainless steel and glass

- Double-glazed door, tool-free removal of the inner glass for easy cleaning
- Handle on right or left (configured on order only)
- Condensate recovery and drain gutter

#### Baking chamber

- All 304 stainless steel
- Rounded bottom corners for easy cleaning
- Diamond point shaped rear and side plates, to prevent deformation
- Direction of ventilation alternates every 30 seconds to ensure homogeneous distribution of air
- Halogen lighting, easy to replace

#### Washing

- Automatic detergent/descaler product dosage according to the cycle selected
- Integrated detergent/descaler product tanks

# Convection, combi and steam baking oven

## Alcor Cook



Models	Alcor Cook 6	Alcor Cook 10
<b>Control</b>		
10" touch control	•	•
Electromechanical control	-	-
<b>Ventilation</b>		
2 fan speeds (1,160 - 1,400 rpm)	-	-
7 fan speeds (810 - 1,440 rpm)	•	•
<b>Functionalities</b>		
Cooking modes: Recipes, Stop Synchro', Multi Chrono', Special cycles, Delta T	•	•
Preheat and temperature hold functions	•	•
Automatic wash	•	•
Automatic steam vent management	•	•
Softbaking function (semi-static baking)	•	•
HygroControl smart humidity management system	•	•
<b>Characteristics</b>		
400x600 slides, 6 levels	•	-
400x600 slides, 10 levels	-	•
GN 1/1 slides, 7 levels	€	-
GN 1/1 slides, 11 levels	-	€
Steam production by direct injection	•	•
Steam production boosted (boiler)	•	•
USB port	•	•
Height-adjustable feet	•	•
Halogen lamp	•	•
Option without anti-limescale filter	-€	-€
<b>Accessories</b>		
Pin type sensor	•	•
Spraying head with automatic hose reel	•	•
12 bottles of 1kg of detergent Alclean**	•	•
1 bottle of 1 kg of anti-scale Alcal**	•	•
<b>Door</b>		
Handle on the left	•	•
Handle on the right	€	€
Condensate recovery and drain gutter	•	•
<b>Steam duct</b>		
Coupling with suitable pipe ø 150 mm	€	€
<b>Water evacuation</b>		
High-temperature water evacuation kit	€	€
<b>Hood</b>		
Hood with extrator	€	€
<b>Stand</b>		
Base without castors, H720 mm with adjustable tray holder for 6 or 12 trays	€	€
Base castors	€	€
Proofbox without castors H 730 mm	€	€
Castors for proofbox	€	€
<b>Oven supply voltage</b>		
3N~380-415 V 50/60 Hz	•	•

\* If the carbonate hardness KH of the water is less than 4 ° dH.

\*\* The warranty is subjected to the use of alclean and alkcal products

# Convection, combi and steam baking oven **Alcor Cook**

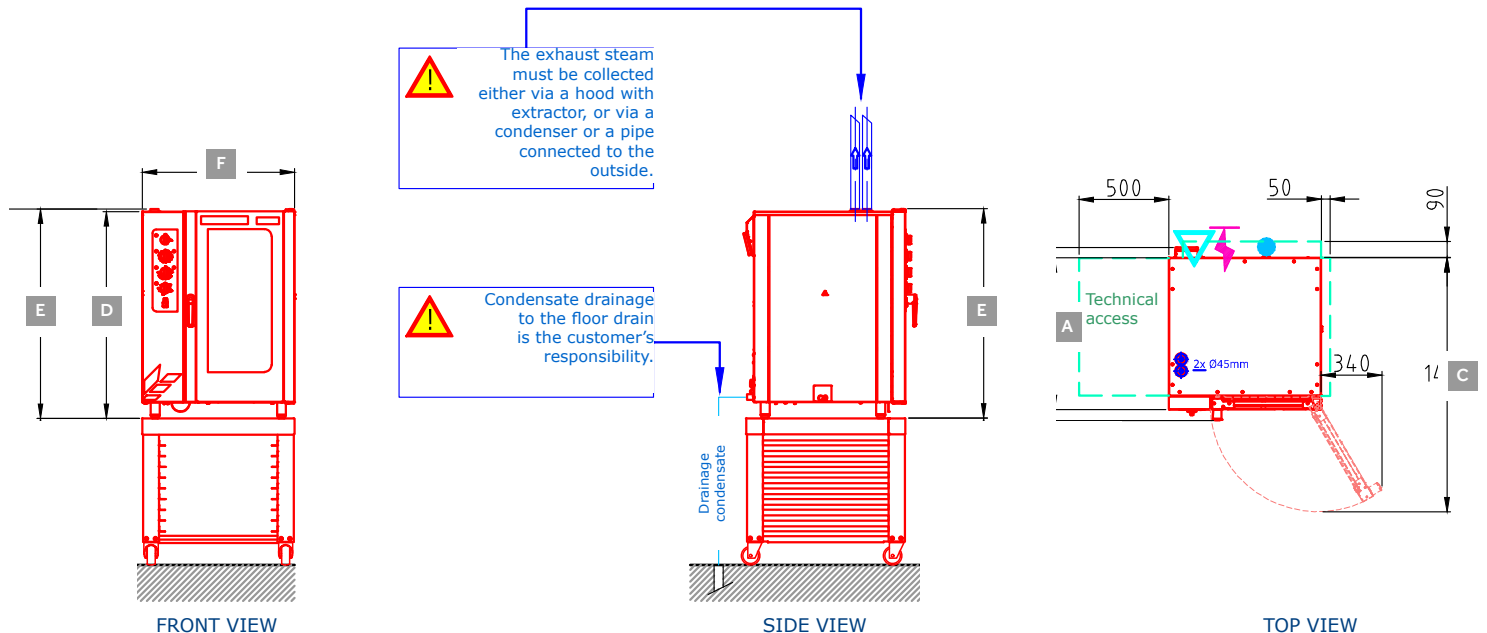

- Condensate drainage Ø 1" (resistance >90°C)
- ⚡ Direct electrical power supply by cable 5X4 mm<sup>2</sup> (H07RN-F) roughed-in at floor level + 1.50 m. Copper wire mandatory
- ▽ Cold water supply: Ø3/4" with shut-off valve
- Steam discharge Ø 45 mm interior

Dimensions and technical features			Alcor Cook 6		Alcor Cook 10	
<b>Oven</b>						
<b>A</b>	Depth	(mm)			845	
<b>B</b>	Overall depth	(mm)			960	
<b>C</b>	Total depth with door open	(mm)			1420	
<b>D</b>	Height	(mm)	870		1150	
<b>E</b>	Overall height	(mm)	890		1170	
<b>F</b>	Floor width	(mm)			850	
	Hood height	(mm)			330	
	Depth hood	(mm)			990	
	Hood weight	(kg)			49	
	Water connection (washing)	(inch)			3/4"	
	Softened water connection (steam)	(inch)			3/4"	
	Discharge	mm			32	
	Floor area	(m <sup>2</sup> )			0,72	
	Total oven weight	(kg)	105		142	
<b>Accessories</b>						
	Base height with castors	(mm)			820	
	Base height without castors	(mm)			720	
	Stand weight	(kg)			37	
	Proofbox height with castors	(mm)			746	
	Proofbox height without castors	(mm)			736	
	Weight of proofbox under the oven	(kg)			58	
<b>Energy characteristics</b>						
	Connection supply	(kW)	18		24	
	Proofbox connection supply	(kW)			1,5	
	Hood connection supply	(kW)			0,2	
	Electrical protection	(A)	32		40	
	Maximum operating temperature	(°C)			280	
	Maximum preheating temperature	(°C)			300	
<b>Water connection</b>						
	Pressure	(bar)			1,5 - 5	

## Convection, combi and steam baking oven **Alcor Cook**

Support specifications	Levels	Spacing (mm)	Max load (kg)	Maximum load
<b>400x600 mm support</b>				
Alcor Cook 6	6	80	35	5
Alcor Cook 10	10		45	
<b>GN 1/1 support (530x325 mm)</b>				
Alcor Cook 6	7	70	35	5
Alcor Cook 10	11		45	

Automatic wash	Time (min)	Water (L)	Alclean (g)
<b>6 levels</b>			
Quick cycle	20	17	90
Gentle cycle	36	26	180
Moderate cycle	52	37	270
Intensive cycle	67	46	360
<b>10 levels</b>			
Quick cycle	20	17	130
Gentle cycle	36	26	260
Moderate cycle	52	37	390
Intensive cycle	67	46	520

Pallet packaging (Carton)		Alcor Cook 6	Alcor Cook 10
Width	(mm)	915	915
Depth	(mm)	1000	1000
Height	(mm)	1045	1330
Total weight	(kg)	123	162

# Krystal



## Convection oven - Electric

### Performances

- 46.4, 46.9 for 400 x 600 pans
- 48.4 and 48.9 for 400 x 800 pans
- Number of decks : 4, 9 or 10 depending on models
- Useful height of baking chamber : 600 or 800 mm

### The advantages

- Oven configurable to the baker's needs
- Oven stand on castors for easy moving into place
- Can be mounted on a stand or manual proofbox
- Deferred startup of the oven
- 3 years warranty on heating elements
- May be combined with a modular deck oven Soleo

### Use

Krystal is an electric convection oven designed to bake all types of breads, pastries and Danish products. Available in 4 or 9 trays - 400 x 600 or 400 x 800 - it can be configured with or without steam generator depending on the user's requirements.

### Operating principle

Products to be baked are placed in corrugated baking trays or pastry pans then loaded in the convection oven. Hot air circulates evenly all over the baking chamber thanks to ventilator(s) located at the rear of the baking chamber. High quality steam in sufficient quantity allows baking of all types of product, even the most hydrated like choux pastries, éclairs, etc.

### Construction

- **Front**
  - polished stainless steel and glass
  - ergonomic handle
  - double glazing windows in door
- **Baking chamber**
  - Stainless steel
  - 4 or 9 levels
  - alternated ventilation cycle
  - halogen lighting
  - motorized steam damper
  - screened stainless steel heating elements
- **Steam generator**
  - double
- **Insulation**
  - crossed rock wool panels

# Convection oven **KRYSTAL**

<b>Models</b>	<b>46.4</b>	<b>46.9</b>	<b>46.10</b>	<b>48.4</b>	<b>48.9</b>
With steam generator	€	€	❖	€	€
Without steam generator	€	❖	€	❖	❖
<b>Control</b>					
Opticom control	■	■	■	■	■
<b>Hood - Exhaust fan</b>					
Hood without exhaust fan	€	€	€	€	€
Hood with exhaust fan	€	€	€	€	€
<b>Condenser</b>					
Condenser	€	€	€	€	€
Wall-mounted condenser	€	€	€	€	€
<b>Oven stand</b>					
Oven stand without castors H850mm with drawer	€	€	€	€	€
Oven stand with castors H850mm with drawer	€	€	€	€	€
Manual S/S proofbox without castors without drawer H850mm	€	€	€	€	€
Manual S/S proofbox with castors with drawer H970mm	€	€	€	€	€
<b>electric power - Oven</b>					
3N~400V	■	■	■	■	■
<b>Electric power - Hood and condenser</b>					
~230V	■	■	■	■	■

<b>Specifications of baking trays</b>						
<b>Products</b>	<b>Number</b>	<b>Levels</b>	<b>Spacing</b>	<b>type of trays</b>	<b>Dimensions</b>	<b>Oven type</b>
Baguettes 200 g	20	4	95	5 AL 600	400 x 600	46.4
Baguettes 250 g	20	4	95	5 AL 800	400 x 800	48.4
	45	9	100	5 AL 800	400 x 800	48.9
Loaves 400 g	16	4	95	4 AL 800	400 x 800	48.4
	36	9	100	4 AL 800	400 x 800	48.9
Pastry and Danish products		4	95	Tray	400 x 600	46.4
		10	90	Tray	400 x 600	46.10
		4	95	Tray	400 x 800	48.4
		9	100	Tray	400 x 800	48.9

# Convection oven **Krystal**

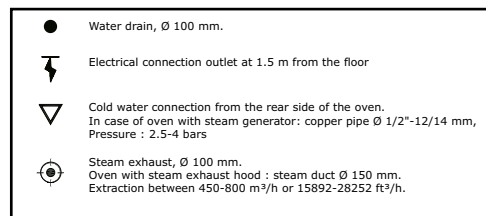
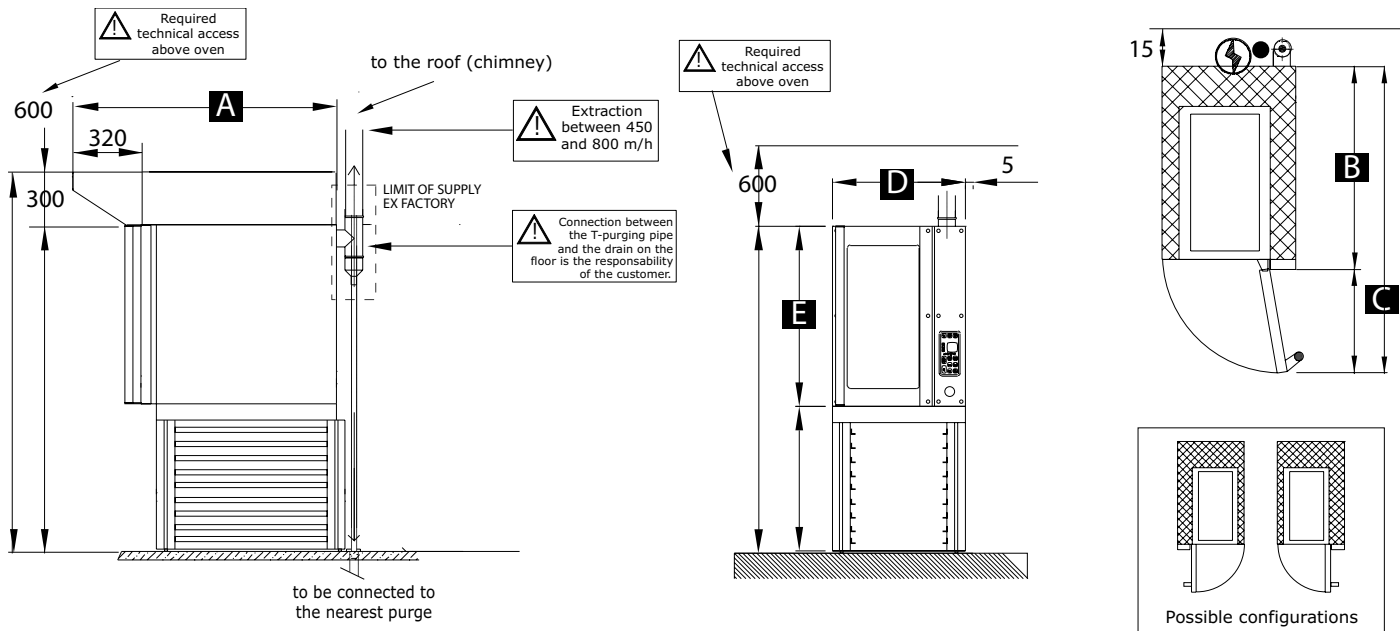

## Technical features

			Oven with steam				Oven without steam	
Dimensions (1m <sup>2</sup> = 10.764 ft <sup>2</sup> )			46.4V	48.4V	46.9V	48.9V	46.4	46.10
<b>A</b>	Depth (with hood)	(mm)	1465	1660	1465	1660	1465	1465
<b>B</b>	depth (with headband)	(mm)	1145	1340	1145	1340	1145	1145
<b>C</b>	Depth (door opened)	(mm)	1705	1900	1705	1900	1705	1705
<b>D</b>	Width, on the floor	(mm)	780	780	780	780	780	780
<b>E</b>	Oven height	(mm)	530	530	1055	1055	530	1055
	Hood height	(mm)	-	-	311	311	-	311
	Floor area	(m <sup>2</sup> )	0,9	1,1	0,9	1,1	0,9	0,9
	Net weight	(kg)	140	160	220	290	140	220
Accessories								
	Oven stand with castors	(mm)	850					
	Oven stand without castors	(mm)	850					
	Net weight (oven stand)	(kg)	18					
	Net weight (oven stand with tray slides)	(kg)	26					
	Proofbox with castors	(mm)	970					
	Proofbox without castors	(mm)	850					
	Net weight (proofbox under the oven)	(kg)	94					
Power (1kg= 2.2046 Lbs)								
	Connecting power	(kW)	10,3	10,3	18,6	18,6	8,3	18,6
	Proofbox connecting power	(kW)	1	1	1	1	1	1
	Hood connecting power	(kW)	0,2	0,2	0,2	0,2	0,2	0,2
	Electric protection	(A)	32	32	40	40	32	40



# Accessories for convection oven Krystal

## Hood

Hood with exhaust fan and lighting

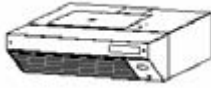

Model		46 / 48
Width	(mm)	780
Height	(mm)	30
Depth	(mm)	1520
Electric power	(W)	155

Ornamental hood with lighting



Model		46 / 48
Width	(mm)	780
Height	(mm)	300
Depth	(mm)	1455
Electric power	(W)	35

## Stands

Height : 850 mm without castors / with drawer



Model		46 / 48
Width	(mm)	780
Height	(mm)	850
Depth	(mm)	1110
Number of levels		9
Spacing between tray slides	(mm)	75

Height : 850 mm with castors / with drawer



Model		46 / 48
Width	(mm)	780
Height	(mm)	850
Depth	(mm)	1110
Number of levels		8
Spacing between tray slides	(mm)	74

## S/S Proofbox

Height : 850 mm without castors / without drawer

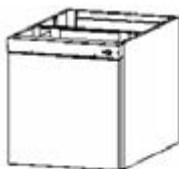

Model		46 / 48
Width	(mm)	780
height	(mm)	850
Depth	(mm)	1160
<b>Proofer capacity (spacing = 75 mm)</b>		
Number of levels		9
Number of door		1
Electric power	(W)	1000
Max. temperature		+40°C
Electric power		~230V

Height : 970 mm with castors / with drawer



Model		46 / 48
Width	(mm)	780
Height	(mm)	970
Depth	(mm)	1190
<b>Proofer capacity (spacing = 75 mm)</b>		
Number of levels		9
Number of door		1
Electric power	(W)	1000
Max. temperature		+40°C
Electric power		~230V

# Configurations Krystal 46.4 / 46.9

## Possible configurations - Variable total heights - Standard width : 780 mm

### Convection ovens 46.4

Height : 2 200 mm

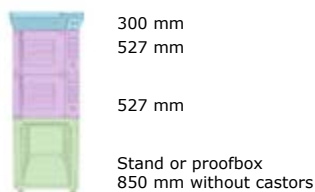

Height : 2 325 mm

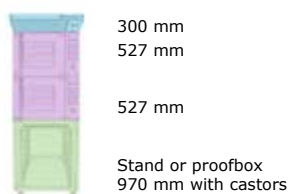

### Convection ovens 46.9

Height : 2 200 mm

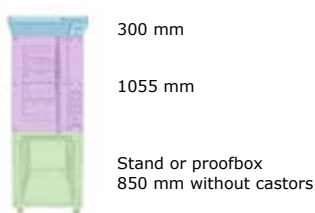

Height : 2 325 mm

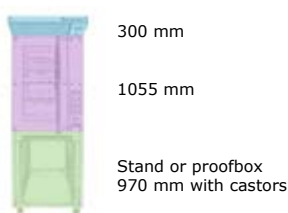

<b>Elements</b>	
<b>Hood 300 mm</b>	
With steam exhaust fan	€
Ornamental hood (only)	€
<b>Convection oven 46.4</b>	
With steam generator	€
Without steam generator	€
<b>Door handle side/ control side</b>	
Door handle and controls on the left	■
Door handle and controls on the right	□
<b>Stands without castors</b>	
Stand height 850 mm	€
Proofbox height 850 mm	€

<b>Elements</b>	
<b>Hood 300 mm</b>	
With steam exhaust fan	€
Ornamental hood (only)	€
<b>Convection oven 46.4</b>	
With steam generator	€
Without steam generator	€
<b>Door handle side / control side</b>	
Door handle and controls on the left	■
Door handle and controls on the right	□
<b>Stands with castors</b>	
Stand height 850 mm	€
Proofbox height 970 mm	€

<b>Elements</b>	
<b>Hood 300 mm</b>	
With exhaust	€
Ornamental hood	€
<b>Convection oven 46.4</b>	
With steam generator	€
Without steam generator	€
<b>Door handle site/ control side</b>	
Door handle and controls on the left	■
Door handle and controls on the right	□
<b>Stands without castors</b>	
Stand height 850 mm	€
Proofbox height 850 mm	€

<b>Elements</b>	
<b>Hood 300 mm</b>	
With exhaust	€
Ornamental hood	€
<b>Convection oven 46.9</b>	
With steam generator	€
Without steam generator	€
<b>Door handle side / control side</b>	
Door handle and controls on the left	■
Door handle and controls on the right	□
<b>Stands with castors</b>	
Stand height 850 mm	€
Proof box height 970 mm	€

# Configurations Krystal 46.4 / 48.4

## Possible configurations - Variable total heights - Standard width : 780 mm

### Convection oven 46.4

Height : 2 200 mm

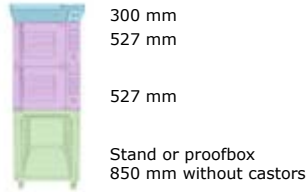

<b>Elements</b>	
<b>Hood 300 mm</b>	
With steam exhaust fan	€
Ornamental hood	€
<b>Convection oven 48.4</b>	
With steam generator	€
<b>Door handle side / Control side</b>	
Door handle and controls on the left	<input checked="" type="checkbox"/>
Door handle and controls on the right	<input type="checkbox"/>
<b>Stands without castors</b>	
Stand height 850 mm	€
Proofbox height 850 mm	€

Height : 2 325 mm

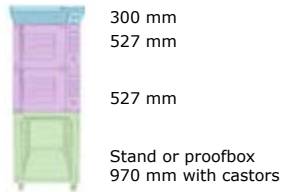

<b>Elements</b>	
<b>Hood 300 mm</b>	
With steam exhaust fan	€
Ornamental hood	€
<b>Convection oven 48.4</b>	
With steam generator	€
<b>Door handle side / Control side</b>	
Door handle and controls on the left	<input checked="" type="checkbox"/>
Door handle and controls on the right	<input type="checkbox"/>
<b>Stands without castors</b>	
Stand height 850 mm	€
Proofbox height 850 mm	€

# Premio



## Convection ovens

### Performances

- 46.4, 46.10 and 64.4 for 400 x 600 pans
- 48.4 and 48.10 for 400 x 800 pans
- Number of decks : 4 or 10 depending on models

### The advantages

- Opticom control with 30 preprogrammed recipes
- Door opening in 2 movements
- Double window in door
- Fitted with 1 steam injector + motorized steam damper (2 injectors for 10 levels models)
- Adjustable fresh air entrance in the baking chamber

### Use

Premio is an electric convection oven designed to bake all types of breads, pastries and Danish products. Available in 4 or 10 trays - 400 x 600 or 400 x 800 - it can be configured with or without steam generator depending on the user's requirements.

### Operating principle

Products to be baked are placed in corrugated baking trays or pastry pans then loaded in the convection oven. Hot air circulates evenly all over the baking chamber. High quality steam in sufficient quantity allows baking of all types of product, even the most hydrated like choux pastries, éclairs, etc.

### Construction

- **Front**
  - polished stainless steel and glass
  - ergonomic handle
  - double glazing windows in door
- **Baking chamber**
  - Stainless steel
  - 4 or 10 levels
  - alternated ventilation cycle
  - halogen lighting
  - motorized steam damper
  - screened stainless steel heating elements
  - 1 steam injector (2 injectors for 10 levels models)
- **Insulation**
  - crossed rock wool panels

## Convection oven **Premio**

<b>Models</b>	<b>46.4</b>	<b>46.10</b>	<b>48.4</b>	<b>48.10</b>	<b>64.4</b>
Premio	€	€	€	€	€
<b>Control</b>					
Opticom control	■	■	■	■	■
<b>Hood</b>					
Hood without exhaust fan	€	€	€	€	€
Hood with exhaust fan	€	€	€	€	€
<b>Stand</b>					
Oven stand with castors H850mm without drawer	€	€	€	€	€
Oven stand with castors H735mm without drawer	€	€	€	€	€
S/S proofbox with castors H850 mm without drawer	€	€	€	€	€
S/S proofbox with castors H970 mm without drawer	€	€	€	€	€
<b>Oven connecting power</b>					
3N~400V	■	■	■	■	■
<b>Hood and condenser connecting power</b>					
~230V	■	■	■	■	■

# Convection oven **Premio**

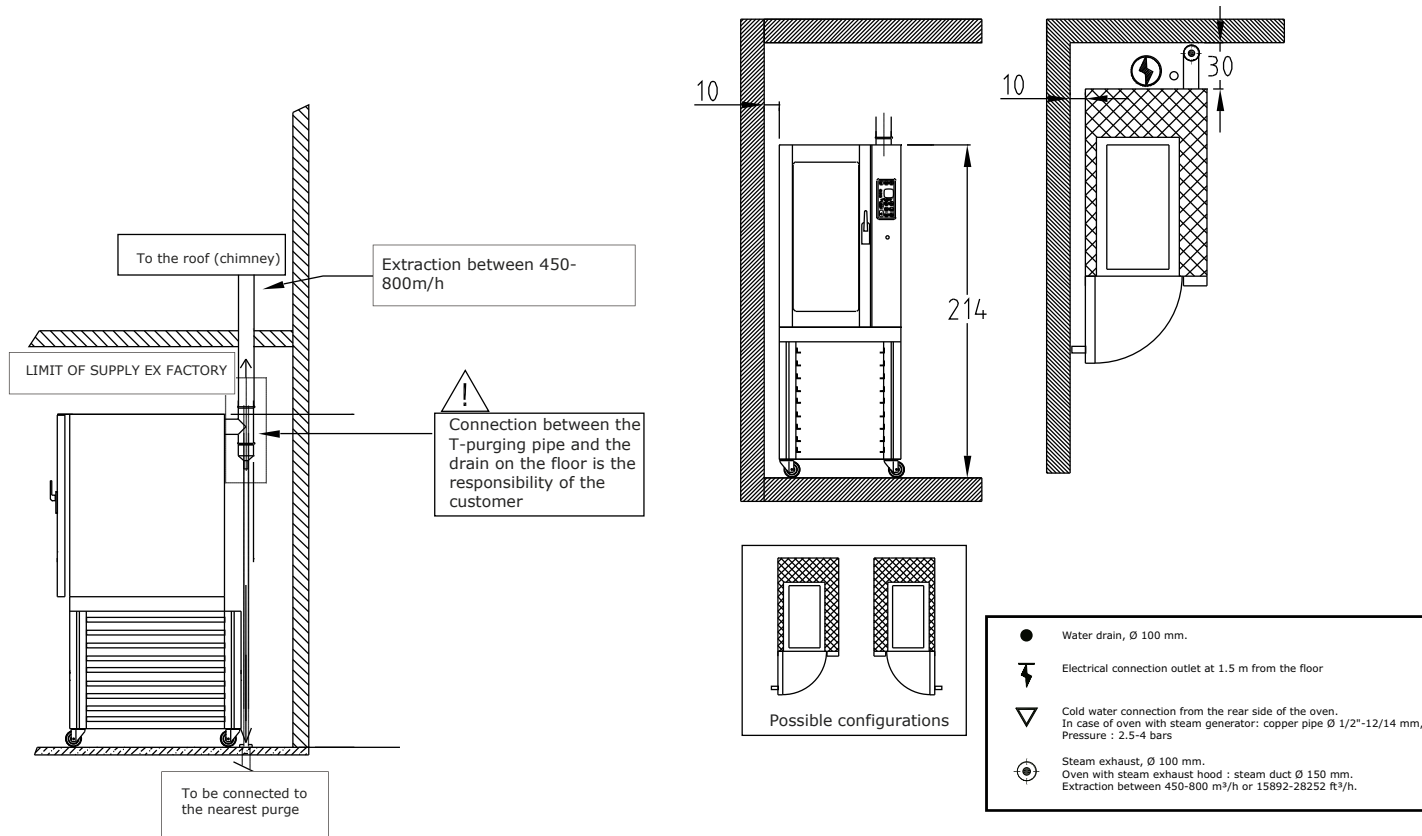

<b>Model</b>		<b>46.4</b>	<b>46.10</b>	<b>64.4</b>	<b>48.4</b>	<b>48.10</b>
Entry		400	400	600	400	400
Height	(mm)	528	1175	528	528	1175
Height overall	(mm)	563	1186	563	563	1186
Width	(mm)	780	780	1000	780	780
Depth overall (+ door handle)	(mm)	1065 + 45	1065 + 45	845 + 45	1265 + 45	1265 + 40
Depth overall door opened	(mm)	1615	1615	1610	1815	1815
Weight	(kg)	100	216	120	120	244
Nb of baking levels		4 / 5	10	4	4 / 5	10
Spacing of	(mm)	5 levels : 70	93	85	5 levels : 70	93
	(mm)	4 levels : 93			4 levels : 93	
<b>Energetic power</b>		<b>46.4</b>	<b>46.10</b>	<b>64.4</b>	<b>48.4</b>	<b>48.10</b>
Power	(kW)	7.5	17	7.5	8.5	17
Voltage		3N~400V				
Electric protection	(A)	16	32	16	32	32
Average gradient of temperature rise	(°C/min)	10 - 12				
Maximum baking temperature of the oven	(°C)	280				

<b>Stand with drawer</b>		<b>Model 46</b>		<b>Model 64</b>		<b>Model 48</b>	
		<b>With feet</b>	<b>With castors</b>	<b>With feet</b>	<b>With castors</b>	<b>With feet</b>	<b>With castors</b>
Capacity (400 x 600 mm plates)		20	14	20	14	❖	❖
Capacity (400 x 800 mm plates)		❖	❖	❖	❖	10	7
Spacing of	(mm)	67	68	67	68	67	68
Height	(mm)	850	735	850	735	850	735

<b>Proofbox</b>		<b>Model 46</b>		<b>Model 64</b>		<b>Model 48</b>	
		<b>With feet</b>	<b>With castors</b>	<b>With feet</b>	<b>With castors</b>	<b>With feet</b>	<b>With castors</b>
Capacity (400 x 600 mm plates)		20	20	16	16	❖	❖
Capacity (400 x 800 mm plates)		❖	❖	❖	❖	10	10
Spacing of	(mm)	66	66	81	81	66	66
Height	(mm)	850	970	850	970	850	970
Nb of doors		1	1	2	2	1	1
Power	(W)	1000	1000	1000	1000	1000	1000
Temperature max.	(°C)	+50	+50	+50	+50	+50	+50

# Condenser



## For convection oven Krystal

### Performances

- Condensation of steam emitted by an oven of up to 10 trays 400x600 or 400 x 800 mm capacity.

### The advantages

- Avoids connection of steam exhaust to a chimney

### Use

Located in the usual position of the steam exhaust hood or headband, the FVE condenser reduces the water content present in the steam leaving the baking chamber, thanks to an air cooled condenser. The oven requires no connection to an external chimney.

### Operating principle

The steam evacuation system is connected to the condenser which will transform more than 80% of the steam into water (to be connected to a drain). The oven and hood can also be connected to the condenser.

### Construction

- Stainless steel front
- Cold battery with fins
- Manual control
- Ventilation : 3 900 m<sup>3</sup>/hour or 137 700 ft<sup>3</sup>
- Collection of condensates by gravity
- Voltage : 230 V Single PH 50 Hz

### • • • Important note :

Hood is not possible with this condenser.

# Condenser for convection oven Krystal

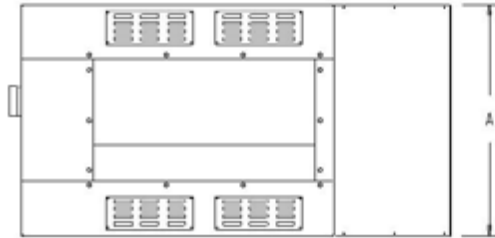
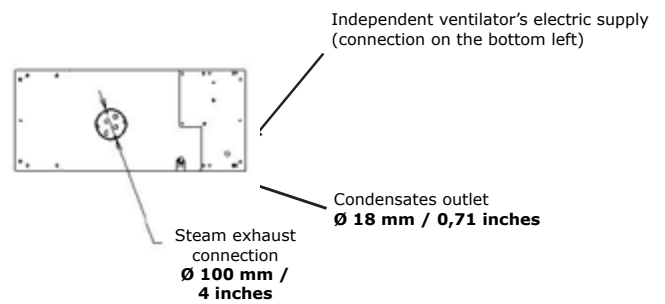
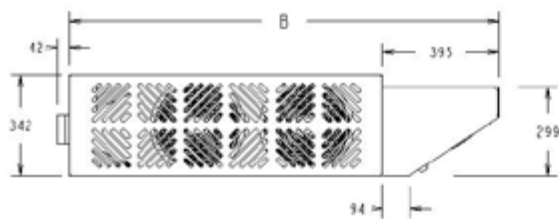

For a normal functioning of condenser, one needs a ventilated area where air is continuously renewed Requested clearance :  
 on the top of the condenser : 200 mm minimum, / 8 inches minimum  
 on both side of the condenser : 150 mm minimum / 6 inches minimum

<b>General features</b>				
<b>Models</b>	<b>A (mm)</b>	<b>B (mm)</b>	<b>C (mm)</b>	<b>Weight (kg)</b>
Krystal 46	780	1451	342	65
Krystal 48	780	1451	342	65

<b>Technical features</b>		
<b>Fan</b>		
Number		2
Power	(kW)	0,15
Noise level	(dBA)	71
<b>Cold battery</b>		
Number of tubes		30
Exchange area	(m <sup>2</sup> )	10,4

<b>Power features</b>		
Electric power	(kW)	0,3
Condensate temperature	(°C)	< 70
Outgoing steam temperature	(°C)	< 30
Condensation performance	(%)	> 80
Electric supply		~230V





# Wall-mounted condenser

For convection oven Krystal

## Performances

- Condensation of steam emitted by an oven of up to 10 trays 400x600 or 400 x 800 mm capacity.

## The advantages

- Equipment independent from the oven
- Avoids connection of steam exhaust to a chimney
- Well suited for electric ovens in particular

## Use

The wall-mounted condenser is used to condensate steam resulting from a baking process. It requires no connection to an external chimney.

## Operating principle

The steam evacuation system is connected to the condenser which will transform more than 80% of the steam into water (to be connected to a drain). The oven and hood can also be connected to the condenser.

## Construction

- Stainless steel body
- « Air-air » exchanger in aluminium and copper
- Oven connection diameter : 100 mm / 4 inches
- Electric supply: 230 V single PH 50 Hz

# Wall-mounted condenser for convection oven Krystal

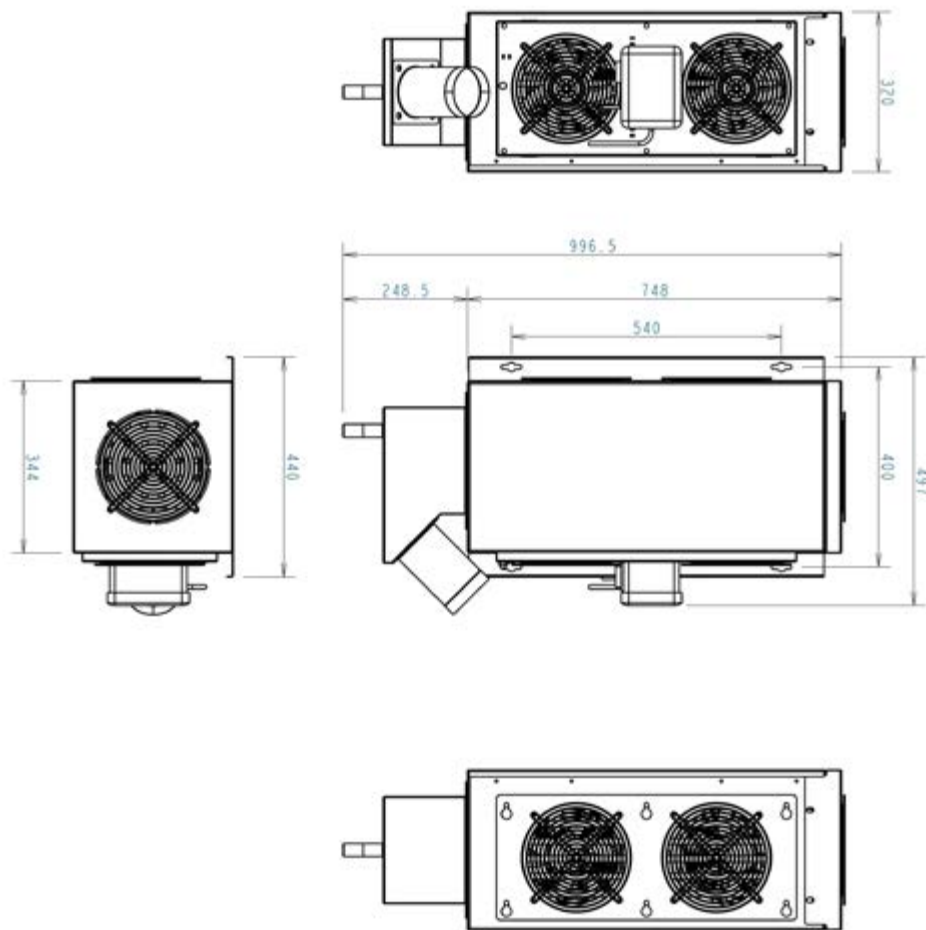

## General features

Models	A	B	C	D	E	F
	(mm)					
Wall-mounted condenser	997	249	748	497	320	344

## Technical features

### Fan

Quantity		2
Power	(kW)	0,15
Noise level	(dBA)	71

### Cold battery

Number of tubes		30
Exchange area	(m <sup>2</sup> )	10,4

## Power features

Electric power	(kW)	0,3
Condensates temperature	(°C)	< 70
Temperature of outgoing steam	(°C)	< 30
Performance condensation	(%)	> 80
Electric supply		~230V

# Soleo / Krystal



## Combinaison of modular deck and convection ovens - Electric

### Performances

Works only with 400 x 600 mm baking trays or pastry pans

### Use

The Soleo/Krystal combined oven can bake in "conduction" mode on hearthplates and in "convection" mode, offering the possibility of baking all types of products in the best of ways.

### Operating principle

Modular oven decks are combined with convection ovens to allow the baker to make all types of products throughout the day.

### Construction

- Oven front in polished stainless steel and glass
- Screened electrical stainless steel heating elements with 3 years warranty
- Performant insulation by crossed rock wool panels

### • • • Important note:

The combination ovens Soleo / Krystal are available in form of kits.

### The advantages

- Possibility of combined use, baking on a deck oven and a convection oven
- Compact
- Oven configurable to the baker's needs
- Oven stand on castors for easy moving into place
- Can be mounted on a stand or manual proofbox
- 3 years warranty on heating

# Combination ovens Soleo / Krystal

## Possible configurations - Standard height: 2 200 mm

### Combination oven Soleo / Krystal 2 trays M2 XS

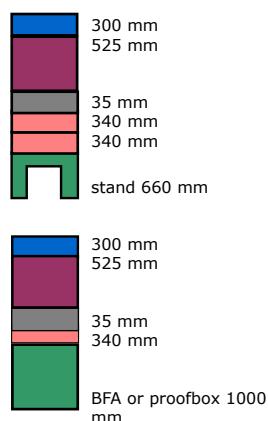

References	With Opticom control
<b>Hood 300 mm</b>	
With steam exhaust fan	€
Without steam exhaust fan	€
<b>convection oven Krystal 46.4</b>	
With steam	€
Without steam	€
<b>Door handle side / Control side</b>	
Door handle on the left / controls on the right	■
Door handle on the right / controls on the left	□
<b>Combination kit M2 35 mm</b>	€
<b>Deck 340 mm</b>	
With steam	€
Without steam	€
<b>Stands</b>	
Stand height 660 mm	€
Stand height 1000 mm	€
BFA height 1000 mm	€
Manual proofbox height 1000 mm	€

### Combination oven Soleo / Krystal 4 trays M2 XL

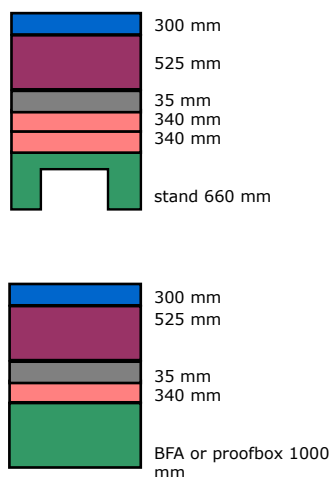

References	With Opticom control
<b>Hood 300 mm</b>	
With steam exhaust fan	□ €
Without steam exhaust fan	□ €
<b>Convection oven Krystal 46.4</b>	
With steam	□ €
Without steam	□ €
<b>Door handle side / Control side</b>	
Door handle on the left / controls on the right	■
Door handle on the right / controls on the left	□
<b>Combination kit M2 35 mm</b>	□ €
<b>Deck 340 mm</b>	
With steam	□ €
Without steam	□ €
<b>Stands</b>	
Stand height 660 mm	□ €
Stand height 1000 mm	□ €
BFA height 1000 mm	□ €
Manual proofbox height 1000 mm	□ €

#### Standard XL :

To make the configurations shown on the side (door handles of convection oven in the centre), specify on order :

- 1 oven door handle on the left / controls on right
- 1 oven door handle on right / controls on left

# Combination ovens Soleo / Krystal

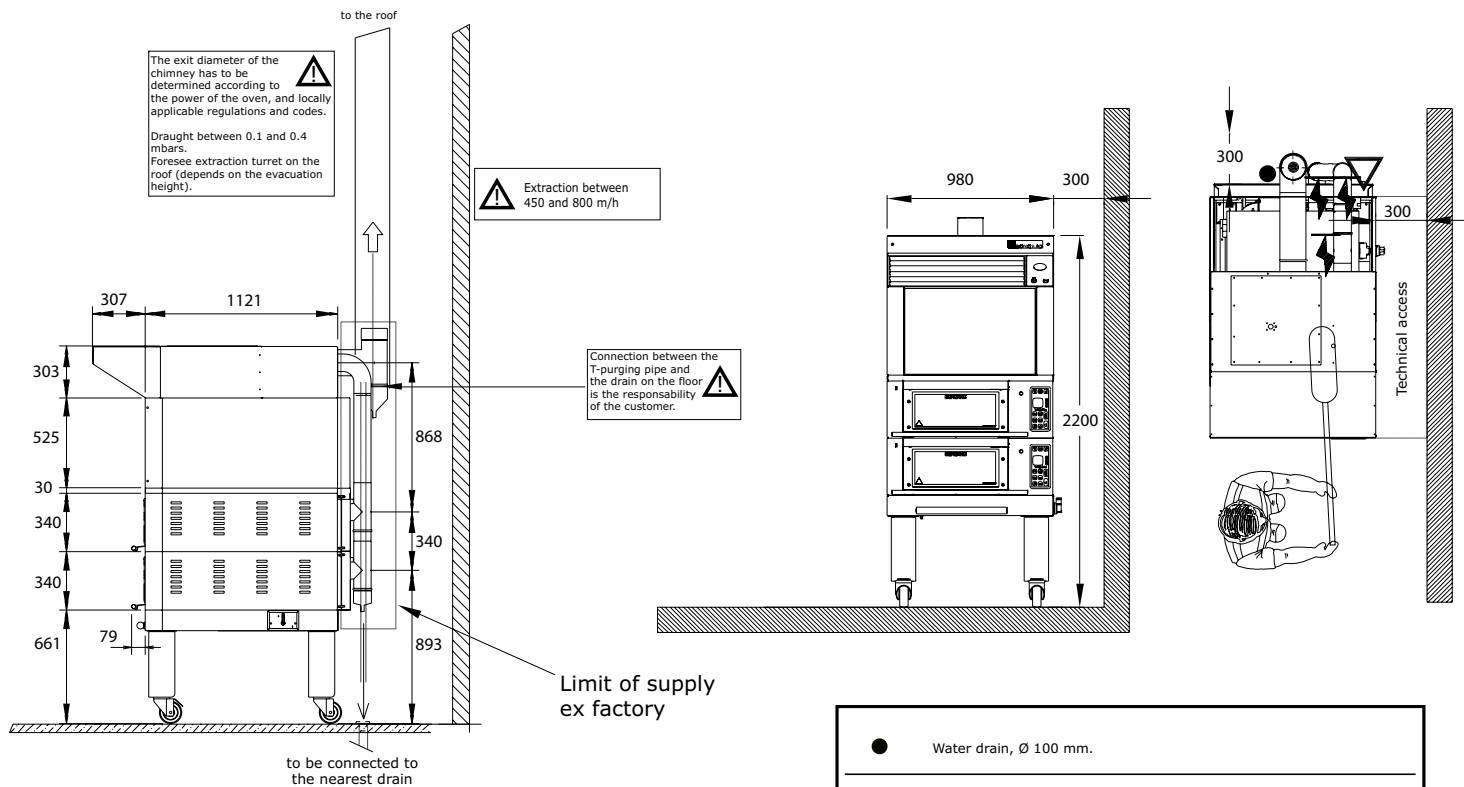

**• • • Important note :**

Required technical access above oven : 600 mm (24 inches)

- Water drain, Ø 100 mm.
- ⚡ Electrical connection from the ceiling, 1 m from the floor.
- ▽ Optional steam generator : water connection from the ceiling. To be connected to a cold water inlet Ø 3/4". Pressure : 2.5-4 bars
- ⊙ Optional steam generator : steam exhaust 700 mm from the floor.
- ⊙ Optional hood : steam exhaust, H= , Ø 200 mm. extraction between 450-800 m<sup>3</sup>/h.

# Intuitiv' 2



## Computerized control panel

### Performances

- 10-inch screen
- Capacitive technology
- Definition: 150 dpi
- Reading of video files
- High durability
- USB port on the front face
- Integrated smooth screen

### Advantages

- Capacitive technology offering more ergonomics and fluidity in oven use to feel comfortable straight away
- 10-inch screen providing for fast and remote visualization
- Visualization of the status of all cooking levels on a single screen
- Ease of creating recipes and dynamic visualization feature
- Simplified recipe management: definition of favorite recipes, filing into folders, search engines
- Possibility to program up to 3 "delayed start/stop" pairs per day
- Programming step facilitated thanks to the copy/paste function
- Optimized energy management using the "Energy Savings" mode
- Data transfer and archival: statistics, recipes and programming sequences by means of a flash drive located on the oven facade
- Cooking menu developed according to the same logic as the initial Intuitiv control: streamlined initiation
- Possibility of creating user profiles with customizable access levels
- Sound alerts customized in response to the various events
- User profiles able to be customized by language, profile photo, screen brightness and alert sound level
- Intuitiv 2 is compatible with a future connectivity function.

### Use

User-friendly and responsive, Intuitiv 2 proposes many new tools developed in the continual aim of better guiding the baker-user through oven operations. Moreover, Intuitiv 2 has benefited from a complete revision of its centralized energy management software. This software, coupled with the integration of new oven control mechanisms, raises the baker's level of excellence through mastering the cooking quality of his/her bakery's products.

### Operating principle

The control offers the possibility to work in "manual" mode for greater flexibility during cooking cycles or in "recipe" mode for an autonomous management of the cooking cycles.

### Features of the Intuitiv'2 controls for deck ovens

- Programming and timer:
  - 3 delayed starts per level and per day
  - 3 delayed stops per level and per day
  - One-time startup modification without affecting the "typical week"
  - Addition of an end of cooking time
  - Copy/paste function for programming delayed starts
  - Programming of one or more «days off»
- Profiles:
  - Customization of profiles
  - Adaptation of the profile access level depending on the user's level of competence
  - The screen has been simplified accordingly.
- Parameters:
  - "Energy Saving" management
  - Management of event-based visual and sound alerts
  - Customization of cooking adjustments
- Statistics:
  - Production performance
  - Energy performance
- Information:
  - Tutorial videos on use of the oven and its controls
  - Notices and technical data sheets
- Data export/import:
  - Production/energy performance, recipes, schedule of delayed starts, user profiles

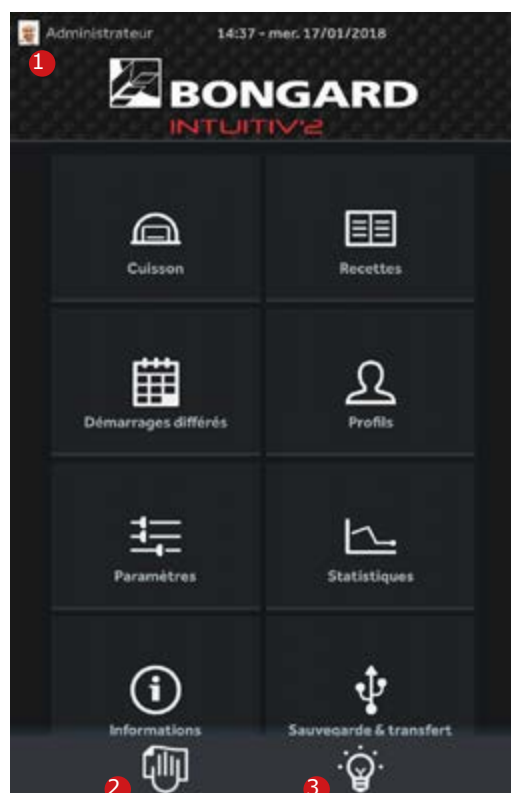

## Home page enabling access to the various menus

- 1 Indicates the active profile and allows changing the user profile
- 2 Shuts down the screen to facilitate its cleaning
- 3 Turns on/off the hood light and each level light

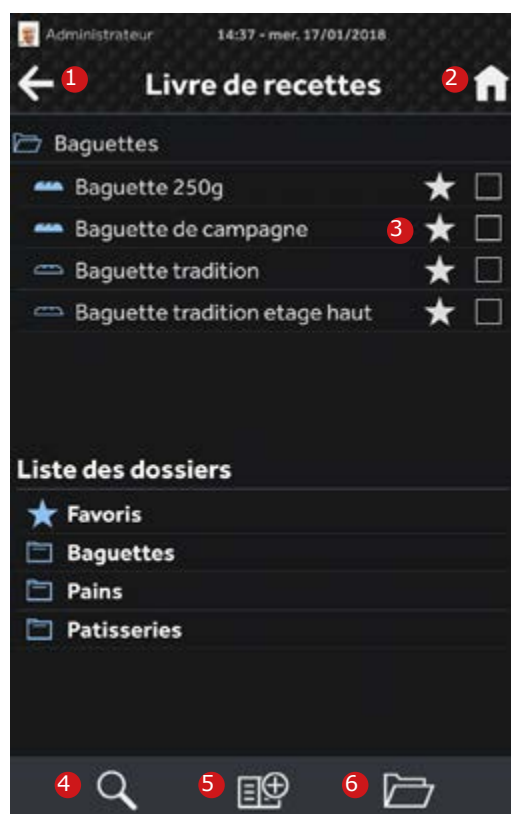

## Recipe menu

- 1 Return to the previous page
- 2 Return to the home page
- 3 Place a recipe in the favorites folder
- 4 Look for a recipe using the search engine
- 5 Create a new recipe
- 6 Visualize the recipe folders



## **Cooking menu :**

- 1 Turn on all levels or place them in standby mode
- 2 Activate an additional timer
- 3 Activate/deactivate the "eco" mode
- 4 Activate/deactivate and select the steam extractor speed
- 5 Turn on/off the hood light and/or the light on all levels

## **On the screenshot:**

**Level 4 :** Cooking underway

**Level 3 :** In standby mode, without any delayed startup

**Level 2 :** In standby mode, with delayed startup

**Level 1 :** Awaiting startup of the cooking cycle, without any delayed startup

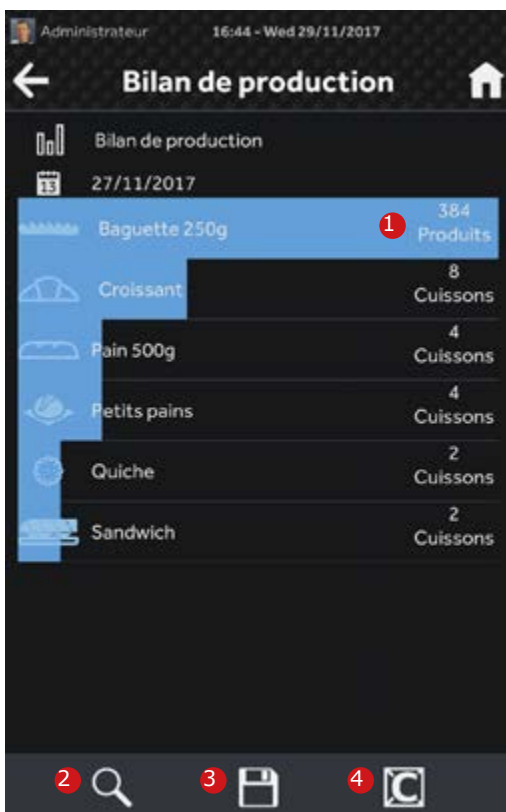

## **Production performance**

- 1 Production readout in number of products and not in number of cooking cycles
- 2 Search for a production performance assessment by date
- 3 Save a production performance assessment
- 4 Visualize the production performance for a given day by 2-hour intervals



# Ergocom



## Electromechanical interface

### Performances

Allows all basic functionalities necessary for baking all types of product.

Works in conjunction with an electromechanical control panel with buttons for : steam, lighting, damper, etc.)

### The advantages

- High visibility LED
- Easy to use
- Optimised pre-heating taking into account the oven's residual temperature

### Use

The 5 keys and the display window allow easy and ergonomic use.

### Operating principle

After having made all the baking settings, the cycle is started by simply pressing the «OK» button.

### Features of the Ergocom with timer :

- Setting and display of baking temperature
- Setting and display of baking time
- Setting and display of the steam injection time (by impulse or long pressing)
- Possibility of programming opening steam damper
- 1 to 3 deferred starts possible per day
- Time display

### Features of the Ergocom without timer :

- Used in addition to Ergocom with timer for all electric deck ovens
- Possibility of setting a temperature

# Electromechanical interface

---

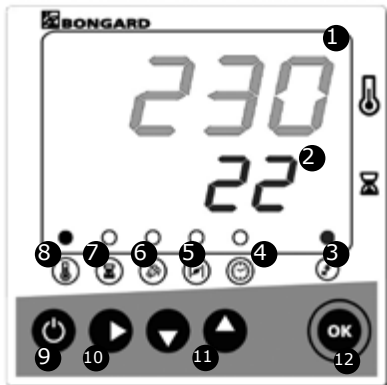

## Ergocom with timer

- ① Display of oven temperature
- ② Display of baking time
- ③ LED lighting= electric current on
- ④ Deferred start-up timer mode
- ⑤ Timer for opening damper at the end of the baking cycle
- ⑥ Timer for steam injection
- ⑦ Baking timer
- ⑧ Temperature setting
- ⑨ ON (start) / deferred start / OFF (standby mode)
- ⑩ Selection of parameter to be modified
- ⑪ Modification of parameters
- ⑫ Validation / Start of baking cycle

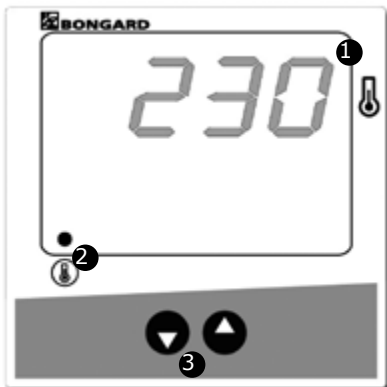

## Ergocom without timer

- ① Display of oven temperature
- ② Temperature setting
- ③ Modification of parameters

# Opticom



## Electronic control panel

### Performances

All the functionalities of an electromechanical control combined with the possibility of programming several recipes.

### The advantages

- High visibility LED
- 2 specific keys for direct access to 2 recipes
- Compact controller integrating parameter settings
- oven management
- easy to clean
- Possibility of saving recipe modifications

### Use

The Opticom can be used in manual mode by a pastry chef or baker or simply in «recipe» mode by a less experienced user.

### Operating principle

In recipe mode:  
just one push on the Start/Stop button and baking mode will be automatically started.

### Features of Opticom for rack ovens:

- Setting and display of pre-heating temperature
- Setting and display of baking temperature
- Setting and display of baking time
- Setting and display of steam injection time
- Possibility of programming opening steam damper
- 14 deferred start-ups possible in one week
- Time display
- 30 pre-programmed recipes

### Features of Opticom for deck ovens:

- Setting and display of top baking plates temperature
- Setting and display of bottom baking plates temperature
- Setting and display of baking temperature
- Setting and display of baking time
- Setting and display of steam injection time
- Possibility of programming opening steam damper
- 14 deferred start-ups possible in one week
- Time display
- 30 pre-programmed recipes

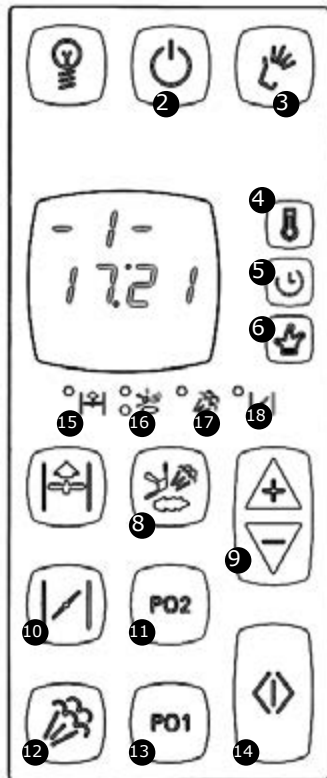

- 1 On/Off, Lighting key
- 2 On/Off, Selection key start-up timer mode
- 3 Manual operation key
- 4 Temperature setting modification key
- 5 Baking time, modification key, time adjustment, start-up timer
- 6 Multifunction (or "Joker") key
- 7 Activation High/Low speeds Stop exhaust fan key
- 8 Low/High ventilation key Burner On/Off key, Steam generator On/Off key
- 9 Modifications key +/-
- 10 On/Off steam damper key
- 11 Direct access key to program 02
- 12 Steam injection key
- 13 Direct access key to program 01
- 14 On/Off cycle key Rack positioning
- 15 Exhaust fan led
- 16 Bottom led : ventilation, burner  
Top led : ventilation, steam generator
- 17 Steam injection led
- 18 Steam damper led

Алматы (7273)495-231  
 Ангарск (3955)60-70-56  
 Архангельск (8182)63-90-72  
 Астрахань (8512)99-46-04  
 Барнаул (3852)73-04-60  
 Белгород (4722)40-23-64  
 Благовещенск (4162)22-76-07  
 Брянск (4832)59-03-52  
 Владивосток (423)249-28-31  
 Владикавказ (8672)28-90-48  
 Владимир (4922) 49-43-18  
 Волгоград (844)278-03-48  
 Вологда (8172)26-41-59  
 Воронеж (473)204-51-73  
 Екатеринбург (343)384-55-89

Ижевск (3412)26-03-58  
 Иваново (4932)77-34-06  
 Иркутск (395)279-98-46  
 Казань (843)206-01-48  
 Калининград (4012)72-03-81  
 Калуга (4842)92-23-67  
 Кемерово (3842)65-04-62  
 Киров (8332)68-02-04  
 Коломна (4966)23-41-49  
 Кострома (4942)77-07-48  
 Краснодар (861)203-40-90  
 Красноярск (391)204-63-61  
 Курск (4712)77-13-04  
 Курган (3522)50-90-47  
 Липецк (4742)52-20-81

Киргизия (996)312-96-26-47

Магнитогорск (3519)55-03-13  
 Москва (495)268-04-70  
 Мурманск (8152)59-64-93  
 Набережные Челны (8552)20-53-41  
 Нижний Новгород (831)429-08-12  
 Новокузнецк (3843)20-46-81  
 Ноябрьск (3496)41-32-12  
 Новосибирск (383)227-86-73  
 Ноябрьск (3496)41-32-12  
 Омск (3812)21-46-40  
 Орел (4862)44-53-42  
 Оренбург (3532)37-68-04  
 Пенза (8412)22-31-16  
 Петрозаводск (8142)55-98-37  
 Псков (8112)59-10-37

Россия (495)268-04-70

Пермь (342)205-81-47  
 Ростов-на-Дону (863)308-18-15  
 Рязань (4912)46-61-64  
 Самара (846)206-03-16  
 Саранск (8342)22-96-24  
 Санкт-Петербург (812)309-46-40  
 Саратов (845)249-38-78  
 Севастополь (8692)22-31-93  
 Симферополь (3652)67-13-56  
 Смоленск (4812)29-41-54  
 Сочи (862)225-72-31  
 Ставрополь (8652)20-65-13  
 Сыктывкар (8212)25-95-17  
 Сургут (3462)77-98-35  
 Тамбов (4752)50-40-97

Казахстан (772)734-952-31

Тверь (4822)63-31-35  
 Тольяти (8482)63-91-07  
 Томск (3822)98-41-53  
 Тула (4872)33-79-87  
 Тюмень (3452)66-21-18  
 Улан-Удэ (3012)59-97-51  
 Ульяновск (8422)24-23-59  
 Уфа (347)229-48-12  
 Хабаровск (4212)92-98-04  
 Чебоксары (8352)28-53-07  
 Челябинск (351)202-03-61  
 Череповец (8202)49-02-64  
 Чита (3022)38-34-83  
 Якутск (4112)23-90-97  
 Ярославль (4852)69-52-93